

**Arthur Few**  
**Professor Emeritus, Research Professor**  
**Physics and Astronomy**  
**Rice University**

---

## **Global Warming**

**I have been lecturing on this subject to my classes for 39 years, so this lecture was condensed from my course lectures and updated with the most current information.**

**My point of view is most certainly that of the scientific community - that global warming is real, it is happening now and will continue into the future, and that the distractors of global warming fail to (or do not wish to) understand the fundamental science of global warming.**

**In this current form of the lecture I have added voiceover to the slides. The commentary is synchronized with the slides; when the audio stops the slides will automatically advance to the next slide.**

**You can pause the slide show at any time using the “f” key (for freeze); to restart use any key.**

## **Part 1:**

**General discussion of temperature and warming, and why there is a disconnect between the scientist and the nonscientist.**

## **Part 2:**

**The science of global warming, this is how it works.**

## Do We Understand Temperature?

What is the temperature of this room?

Where would you measure the temperature of this room?

How would you measure the temperature?

When do you measure the temperature of the room?

Can we call this measurement the “average” room temperature?

We have illustrated some complexities in the meaning of temperature. Temperature is a point measurement, and when applied to an extended object, we must agree on the specifics of where, how, and when to make a consensus “room temperature” measurement. Beyond this we must also reach a consensus on what averages we want to know.

You can pause the slide show at any time using the “f” key (for freeze); to restart use any key.

## **So, what is the temperature of the Earth?**

**Where do we place the thermometers?**

**How do you average these spatially diverse measurements?**

**How long should the record be to give a significant average measurement?**

**Difficult as it might be there are experts that labor over the global data set and carefully weigh the quality and distribution of the data to achieve the mean global temperature and its changes over time. These are peer reviewed and become consensus determinations. The following slide provides a summary of the many attempts to determine the global temperature.**

**I recommend that you pause the next slide after the commentary is finished and study the slides details.**

**You can pause the slide show at any time using the "f" key (for freeze); to restart use any key.**

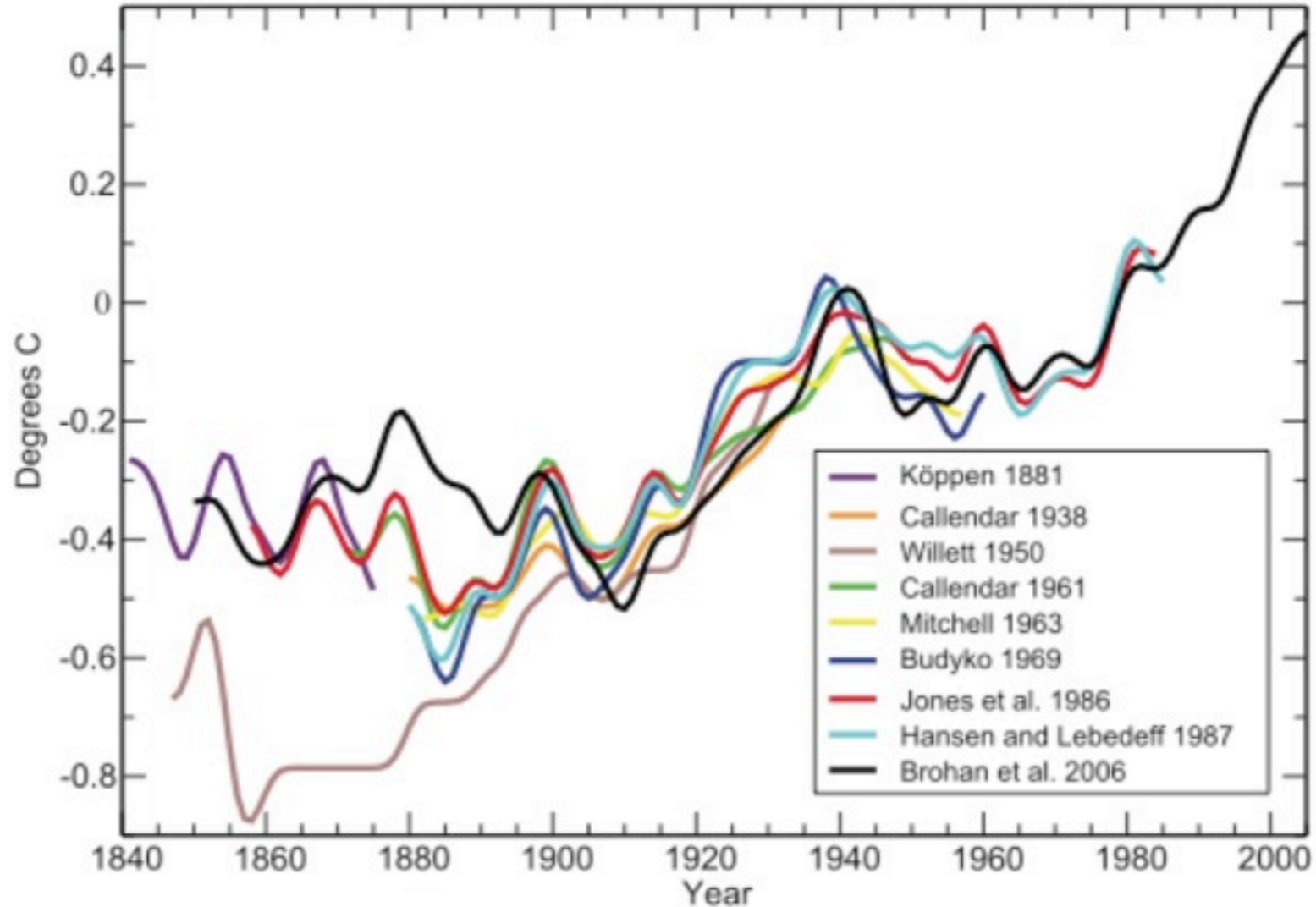

**Figure 1.3.** *Published records of surface temperature change over large regions. Köppen (1881) tropics and temperate latitudes using land air temperature. Callendar (1938) global using land stations. Willett (1950) global using land stations. Callendar (1961) 60°N to 60°S using land stations. Mitchell (1963) global using land stations. Budyko (1969) Northern Hemisphere using land stations and ship reports. Jones et al. (1986a,b) global using land stations. Hansen and Lebedeff (1987) global using land stations. Brohan et al. (2006) global using land air temperature and sea surface temperature data is the longest of the currently updated global temperature time series (Section 3.2). All time series were smoothed using a 13-point filter. The Brohan et al. (2006) time series are anomalies from the 1961 to 1990 mean (°C). Each of the other time series was originally presented as anomalies from the mean temperature of a specific and differing base period. To make them comparable, the other time series have been adjusted to have the mean of their last 30 years identical to that same period in the Brohan et al. (2006) anomaly time series.*

Brohan P., et al., 2006: Uncertainty estimates in regional and global observed temperature changes: A new data set from 1850. *J. Geophys. Res.*, **111**, D12106, doi:10.1029/2005JD006548.

You can pause the slide show at any time using the “f” key (for freeze); to restart use any key.

**In order to make any sense out of global temperature data sets, the measurements must be “massaged”- calibrated, adjusted, smoothed, averaged, etc. This is not an easy task, but once this is done with historical data, new data sets can be added using the consensus methodology.**

**I think there is a more convincing way to measure global warming; that is to let the Earth do the averaging for us. We can observe changes in glaciers. Changes in sea ice, land ice, and snow cover. Changes in insect populations. Changes in soil moisture. Changes in vegetation. These and many other Earth System components respond to changes in climate.**

**Before we examine some of these Earth-integrated observed changes let's look at another obstacle in the communication between the scientist and the nonscientists.**

## Do We Understand Warming?

We will perform a *gedanken* experiment. This is a virtual or thought experiment. I think that we are all sufficiently familiar with the behavior of the experiment that we can bypass actually doing it.

We have a block of ice into which we drill a hole to its center and insert a thermometer. We next place the block of ice into a pot and place the pot on a burner of a stove. We turn the burner on and record the temperature. **We are warming the pot!**

Now, you tell me what happens initially?

The temperature does not change (it is 0°C), but **we are warming the pot.**

Now what happens next?

When the ice melts the temperature increases; **we are still warming the pot.**

What happens next?

When the water starts boiling the temperature is again constant (100°C). And **we are still warming the pot.**

*Conclusion.* Increasing temperature is not a necessary test of warming. The Earth system is much much more complex than our pot of ice/water. The “mean global temperature” may not always reflect global warming. The most frequent misunderstanding made by nonscientists is to interpret global warming as increasing temperatures. How often I have heard people say things like, “How can this be global warming when we have had such a cold winter here in the mid-west?”



**In my opinion, the scientific community made a mistake decades ago when trying to convince the general public of the dangers of global warming by focusing upon global temperature. It simply doesn't convey the proper message.**

**Suppose you tell your Houston business persons that by 2020 the global average temperature will increase by 1°C. What probably goes through their mind is, "Gosh, will I be able to play golf in January?"**

**The global average temperature does not properly convey the real message of global warming, and may, in fact, be misleading to the general public.**

**Take this example: the oceans have a huge heat capacity compared to the atmosphere and land (the part that interacts with weather and climate changes). For a 1°C change in the "global average temperature" the oceans might change by 0.2°C while the land change would be 3°C. I can assure you the increasing our average mid-continent land temperature 3°C will lead to droughts and extensive agriculture failures.**

**The scientific community has now realized the importance of forecasting regional impacts of global warming and pointing to the observed changes that are already taking place.**



# **Some Observed Consequences of Global Warming**

**(IPCC Report AR4, November 2007, and AR3, September 2001)**

**Eleven of the last twelve years (1995-2006) rank among the twelve warmest years in the instrumental record of global surface temperature (since 1850).**

**Rising sea level is consistent with warming.**

**Observed decreases in snow and ice extent are also consistent with warming. Arctic sea ice extent has shrunk by ~3% per decade, with larger decreases in summer of ~7% per decade.**

**It is very likely that over the past 50 years: cold days, cold nights and frosts have become less frequent over most land areas, and hot days and hot nights have become more frequent.**

**There is observational evidence of an increase in intense tropical cyclone activity in the North Atlantic since about 1970.**

**Average Northern Hemisphere temperatures during the second half of the 20th century were very likely higher than during any other 50-year period in the last 500 years and likely the highest in at least the past 1300 years.**

**Changes in snow, ice and frozen ground have with high confidence increased the number and size of glacial lakes, increased ground instability in mountain and other permafrost regions and led to changes in some Arctic and Antarctic ecosystems.**

**In terrestrial ecosystems, earlier timing of spring events and poleward and upward shifts in plant and animal ranges are with very high confidence linked to recent warming.**

**There has been a widespread retreat of mountain glaciers in non-polar regions during the 20th century.**

**It is likely that there has been about a 40% decline in Arctic sea-ice thickness during late summer to early autumn in recent decades and a considerably slower decline in winter sea-ice thickness.**

**Tide gauge data show that global average sea level rose between 0.1 and 0.2 meters during the 20th century.**

**Warm episodes of the El Niño-Southern Oscillation (ENSO) phenomenon (which consistently affects regional variations of precipitation and temperature over much of the tropics, sub-tropics and some mid-latitude areas) have been more frequent, persistent and intense since the mid-1970s, compared with the previous 100 years.**

**Ocean waters are becoming more acidic as they soak up carbon dioxide, the main global warming gas. And while there's evidence that coral reefs can find ways to adapt to waters warmed by global climate change, there's no proof that they can cope with more-acidic oceans. But a new research paper in the journal Science says their problems may be getting worse. The paper says as much as a third of the world's coral species may now be headed toward extinction.**

**Climate change is "largely irreversible" for the next 1,000 years even if carbon dioxide (CO<sub>2</sub>) emissions could be abruptly halted, according to a new study published in this week's Proceedings of the National Academy of Sciences (1/29/09). This is because the oceans are currently soaking up a lot of the planet's excess heat — and a lot of the carbon dioxide put into the air. The carbon dioxide and heat will eventually start coming out of the ocean. And that will take place for many hundreds of years.**

## **Some Personal Observations.**

**Drunken Trees**

**Missing Glacier**

(Turnagain Arm & Portage Glacier; also Glacier National Park and Kilimanjaro)

**Grosbeaks & Crossbeaks**

**House Finches**

**Yellowjackets**

**Pine Bark Beetles**

(Entomologist say 4 consecutive days Of -10°F required to kill a beetle larva.)

**Ips Bark Beetle**

**Gulf Coast Hurricanes**

Ike, Gustav, Dolly, Humberto, Dean, Ernesto, Cindy, Dennis, Emily, Katrina, Rita, Stan, Wilma, Beta, 2005 used up the alphabet then switched to Greek - alpha through zeta.

**Wildfires**

# Earth's Effective Temperature

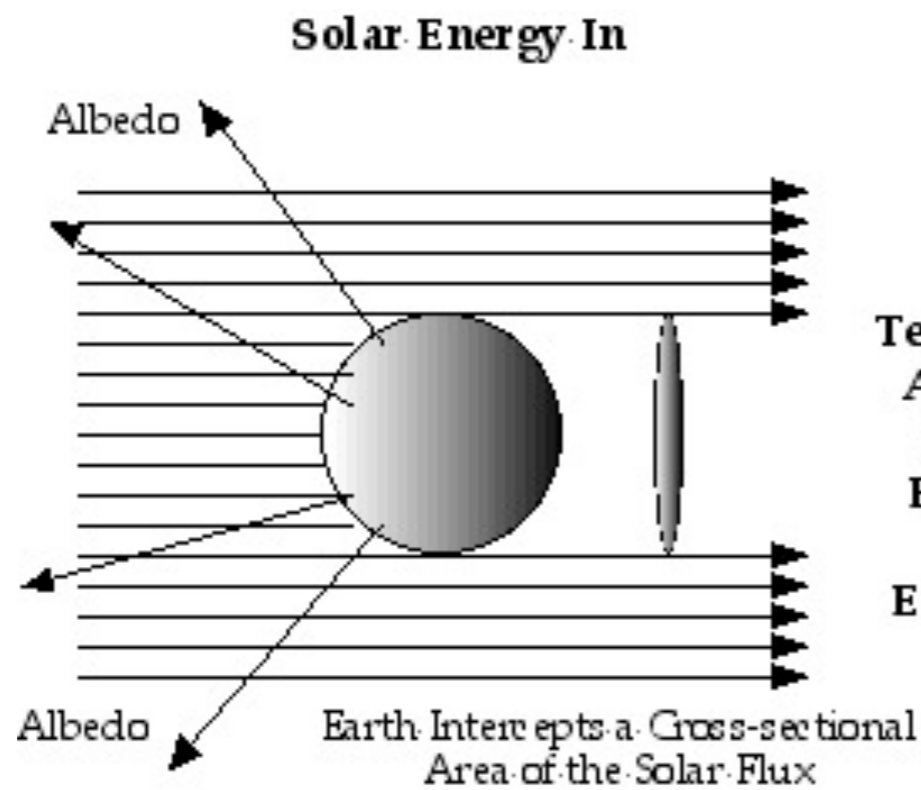

Earth's Temperature Adjusts to Balance Energy In with Energy Out

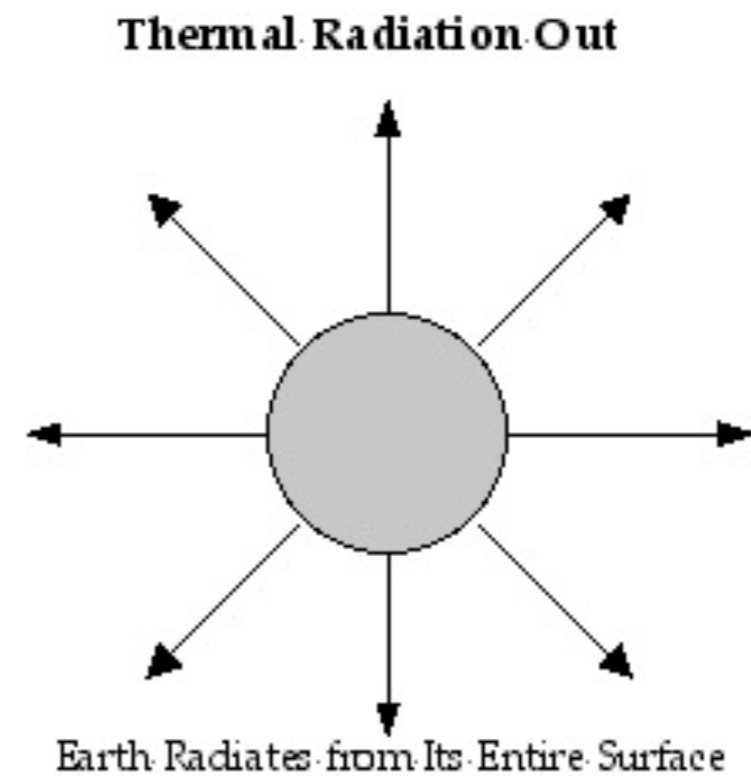

$\sigma T_E^4$ , Stefan-Boltzmann law  
 $\sigma = 5.67 \times 10^{-8} \text{ J/sm}^2\text{K}^4$   
 $S = 1366 \text{ J/sm}^2 \quad dS = 0.07\%$   
 $A = 0.30 \text{ (28 - 30)}$

# Earth's Effective Temperature

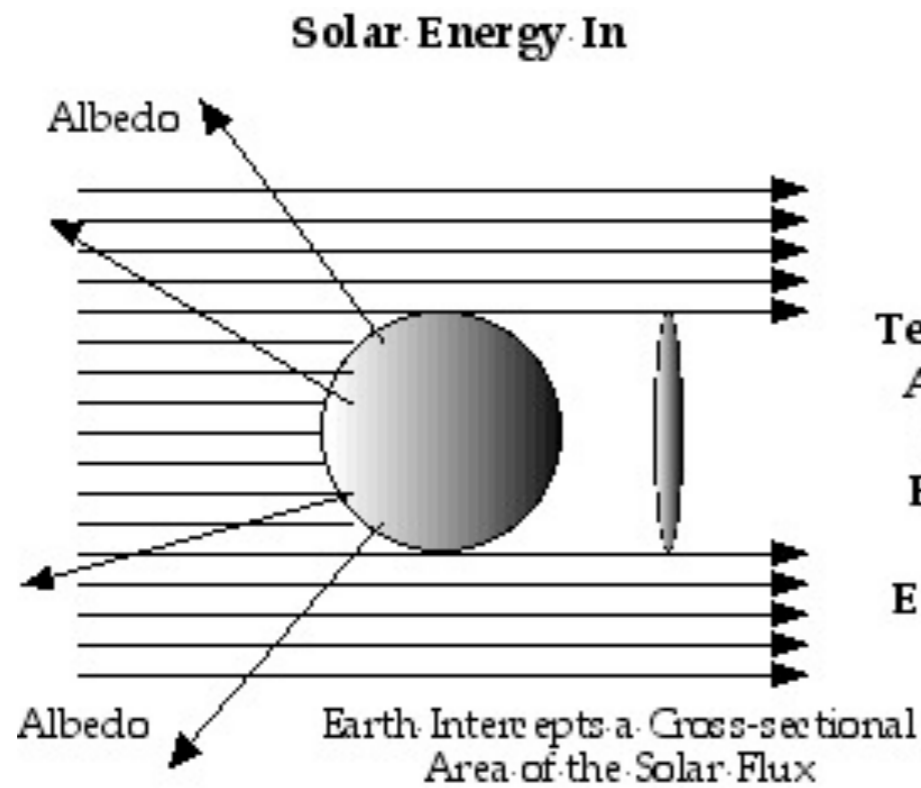

Earth's Temperature Adjusts to Balance Energy In with Energy Out

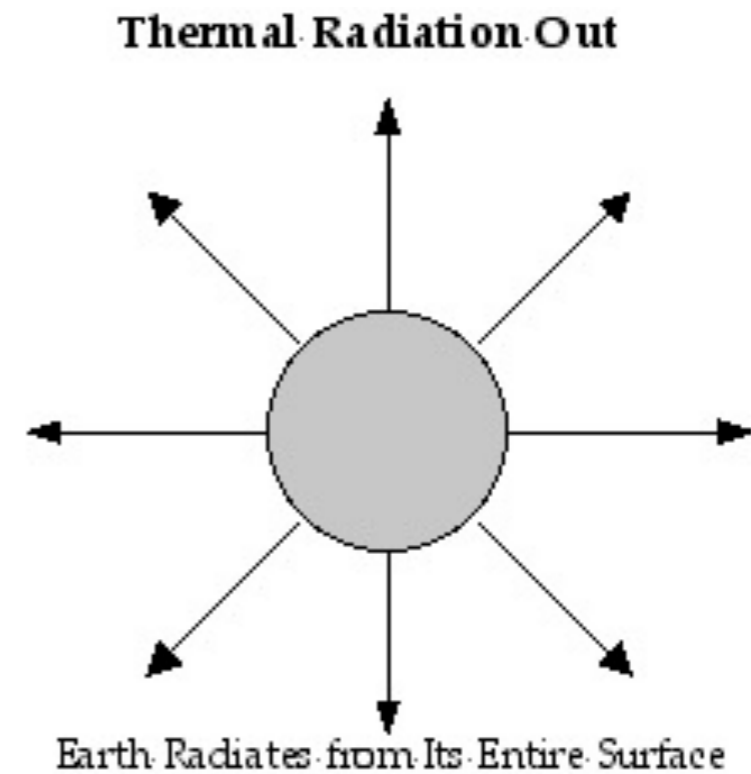

$$\text{Power In} = S(1-A)\pi R_E^2$$

$\sigma T_E^4$ , Stefan-Boltzmann law  
 $\sigma = 5.67 \times 10^{-8} \text{ J/sm}^2\text{K}^4$   
 $S = 1366 \text{ J/sm}^2$   $dS = 0.07\%$   
 $A = 0.30$  (28 - 30)

# Earth's Effective Temperature

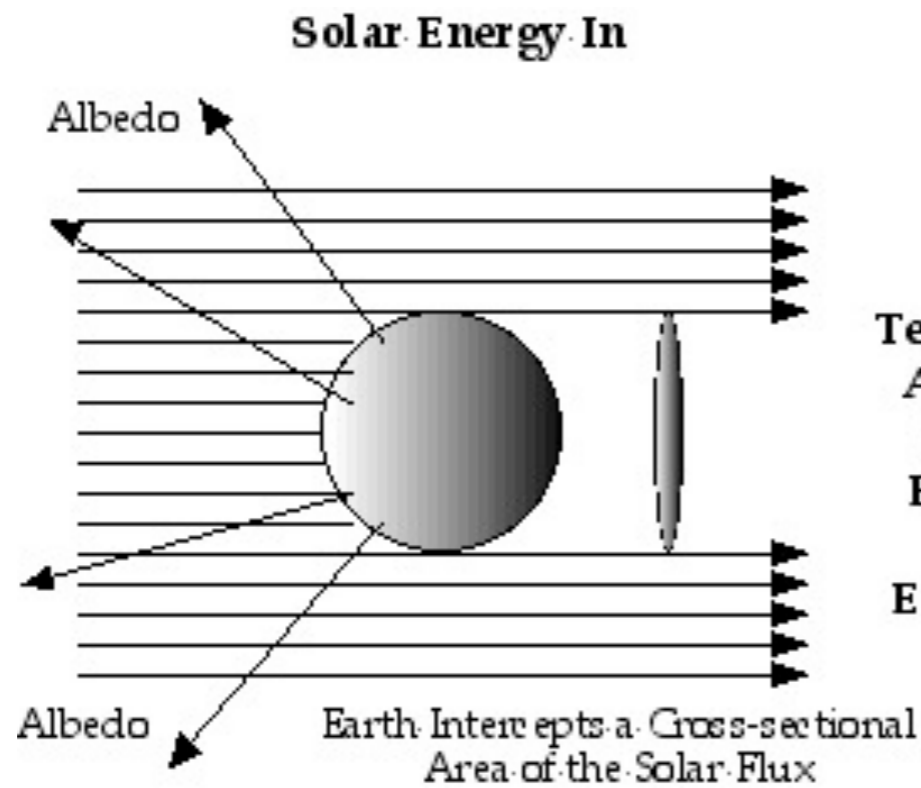

Earth's Temperature Adjusts to Balance Energy In with Energy Out

$$\text{Power In} = S(1-A)\pi R_E^2$$

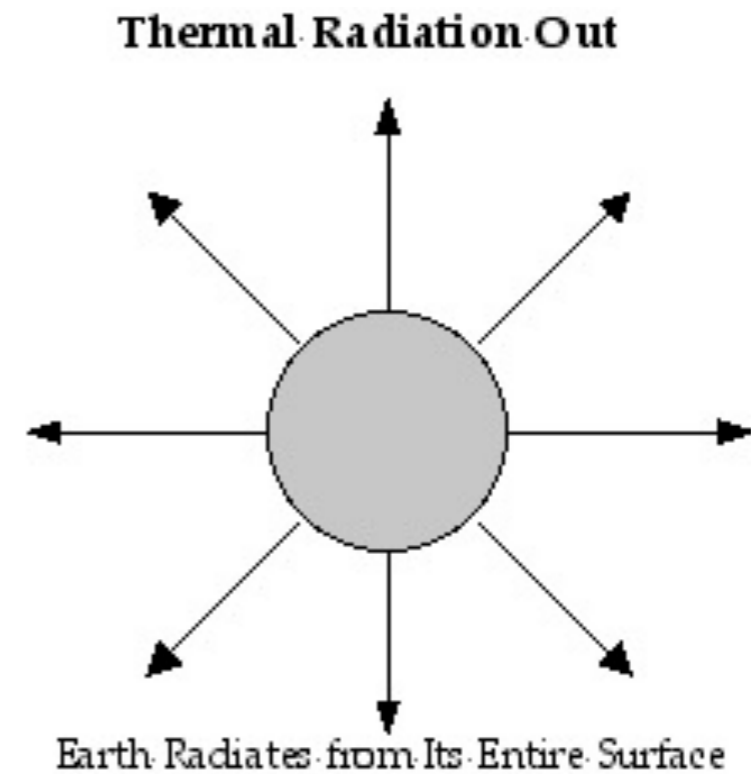

$$\text{Power Out} = 4\pi R_E^2 \sigma T_E^4$$

$\sigma T_E^4$ , Stefan-Boltzmann law  
 $\sigma = 5.67 \times 10^{-8} \text{ J/sm}^2\text{K}^4$   
 $S = 1366 \text{ J/sm}^2$   $dS = 0.07\%$   
 $A = 0.30$  (28 - 30)

# Earth's Effective Temperature

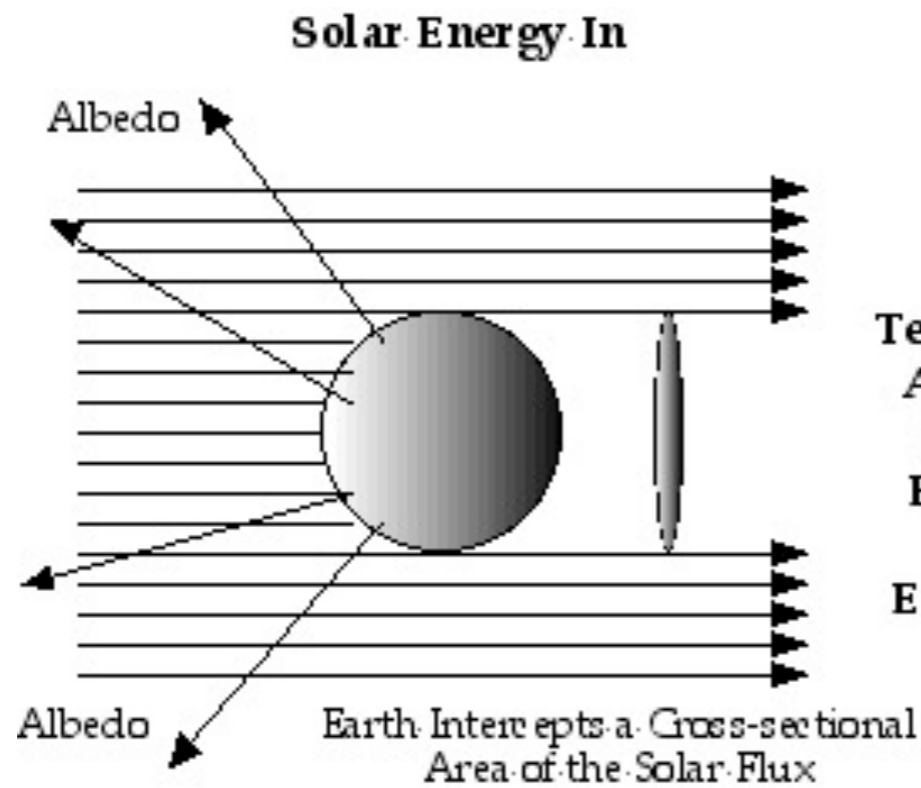

Earth's Temperature Adjusts to Balance Energy In with Energy Out

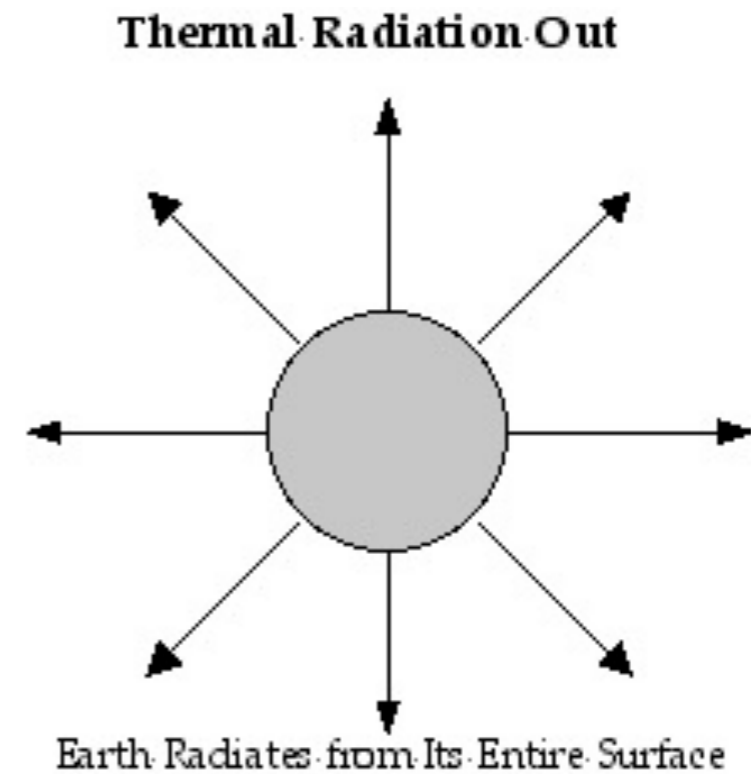

$$\text{Power In} = S(1-A)\pi R_E^2$$

$$\text{Power Out} = 4\pi R_E^2 \sigma T_E^4$$

$$T_E = [S(1-A)/4\sigma]^{1/4}$$

$\sigma T_E^4$ , Stefan-Boltzmann law  
 $\sigma = 5.67 \times 10^{-8} \text{ J/sm}^2\text{K}^4$   
 $S = 1366 \text{ J/sm}^2$   $dS = 0.07\%$   
 $A = 0.30$  (28 - 30)



# Earth's Effective Temperature

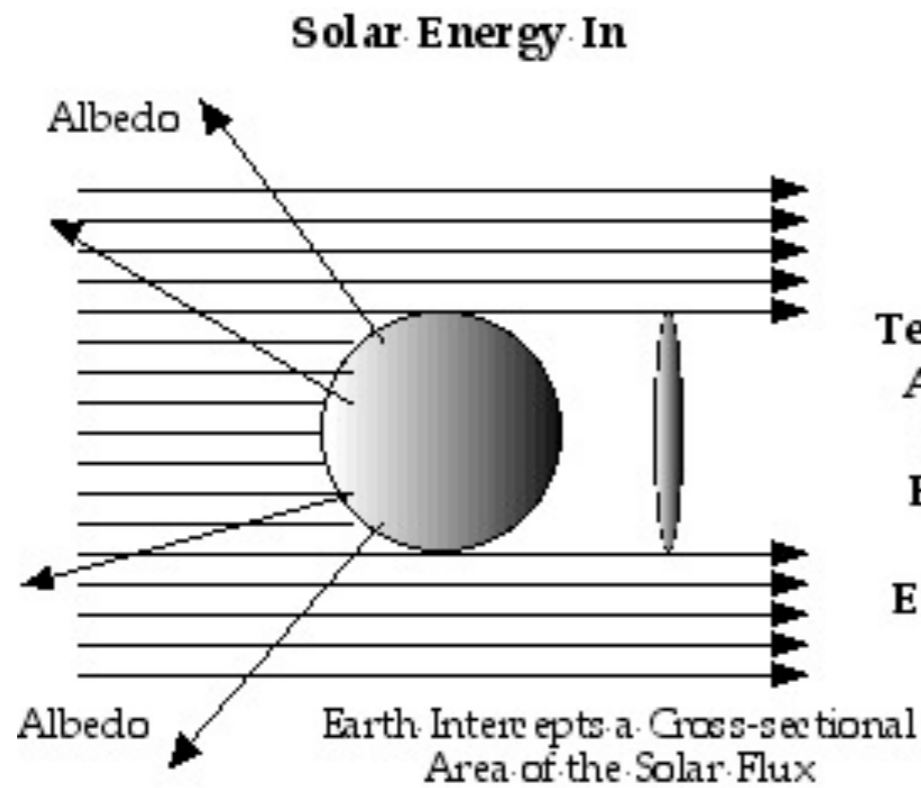

$$\text{Power In} = S(1-A)\pi R_E^2$$

Earth's Temperature Adjusts to Balance Energy In with Energy Out

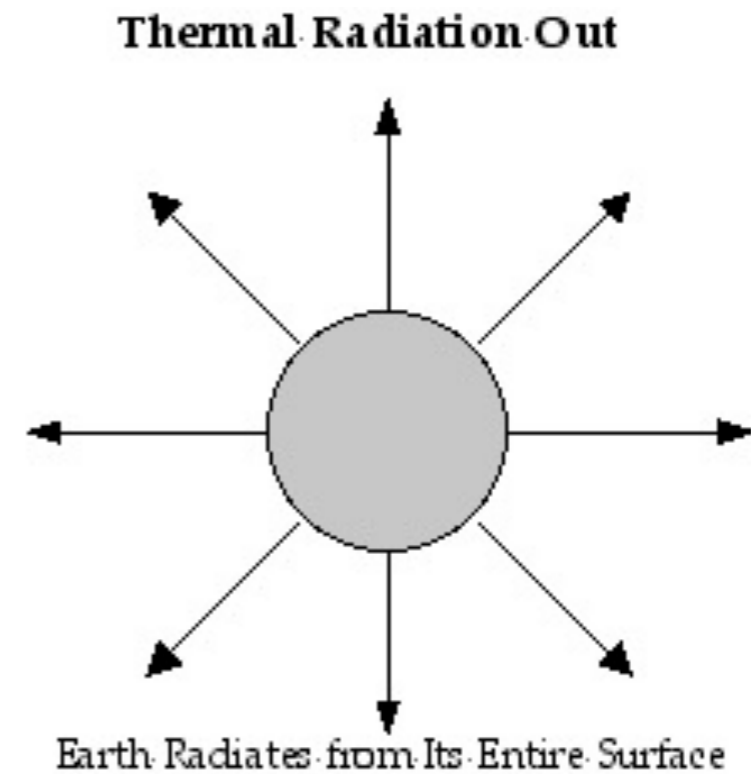

$$\text{Power Out} = 4\pi R_E^2 \sigma T_E^4$$

$$T_E = [S(1-A)/4\sigma]^{1/4}$$

$$T_E = 255^\circ\text{K} = -18^\circ\text{C}$$

That's Cold!

$\sigma T_E^4$ , Stefan-Boltzmann law  
 $\sigma = 5.67 \times 10^{-8} \text{ J/sm}^2\text{K}^4$   
 $S = 1366 \text{ J/sm}^2$   $dS = 0.07\%$   
 $A = 0.30$  (28 - 30)

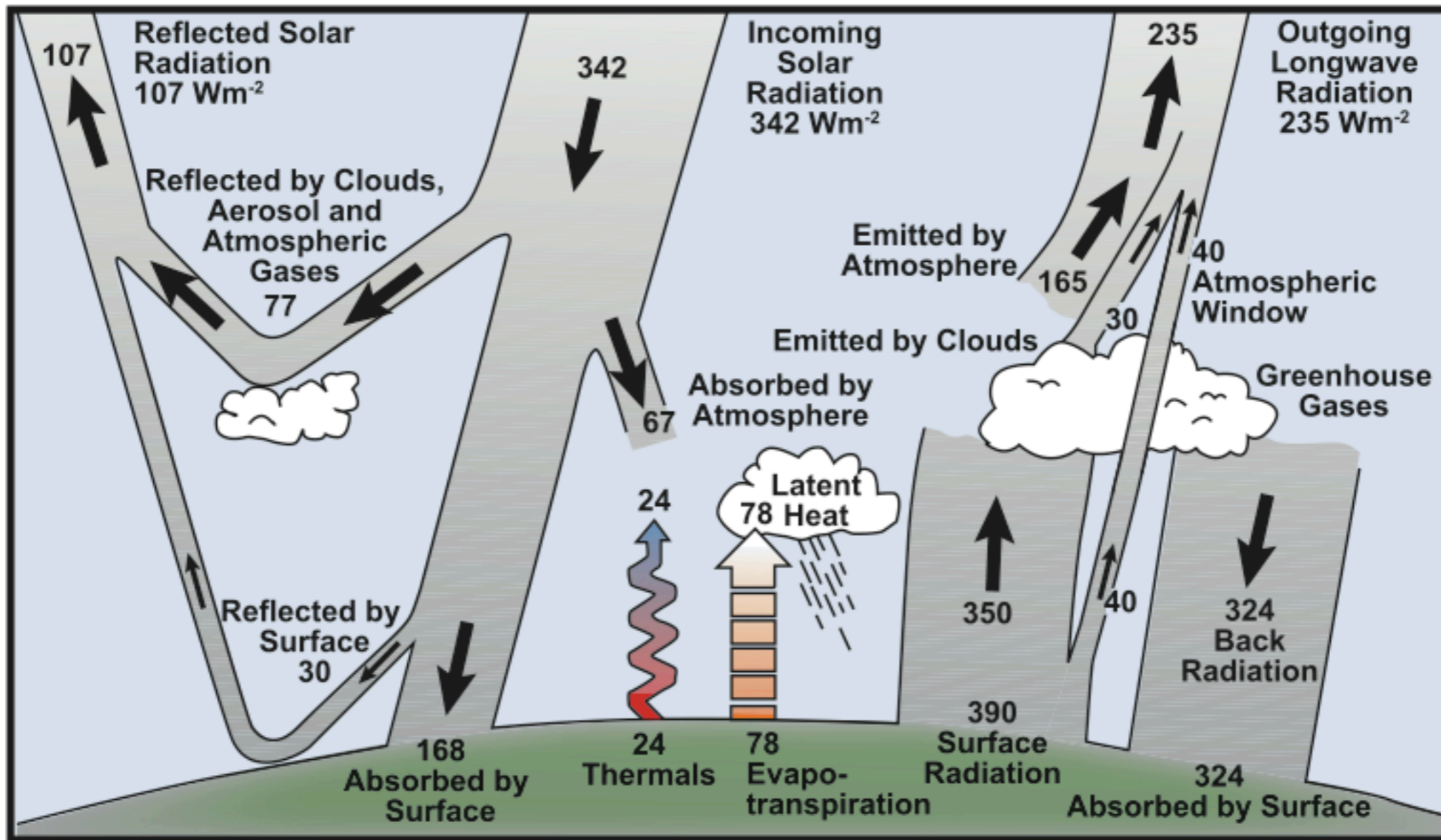

**FAQ 1.1, Figure 1.** Estimate of the Earth's annual and global mean energy balance. Over the long term, the amount of incoming solar radiation absorbed by the Earth and atmosphere is balanced by the Earth and atmosphere releasing the same amount of outgoing longwave radiation. About half of the incoming solar radiation is absorbed by the Earth's surface. This energy is transferred to the atmosphere by warming the air in contact with the surface (thermals), by evapotranspiration and by longwave radiation that is absorbed by clouds and greenhouse gases. The atmosphere in turn radiates longwave energy back to Earth as well as out to space. Source: Kiehl and Trenberth (1997).

Also, the global mean includes the polar regions. By the way, the tropical cloud tops are colder than the polar regions.

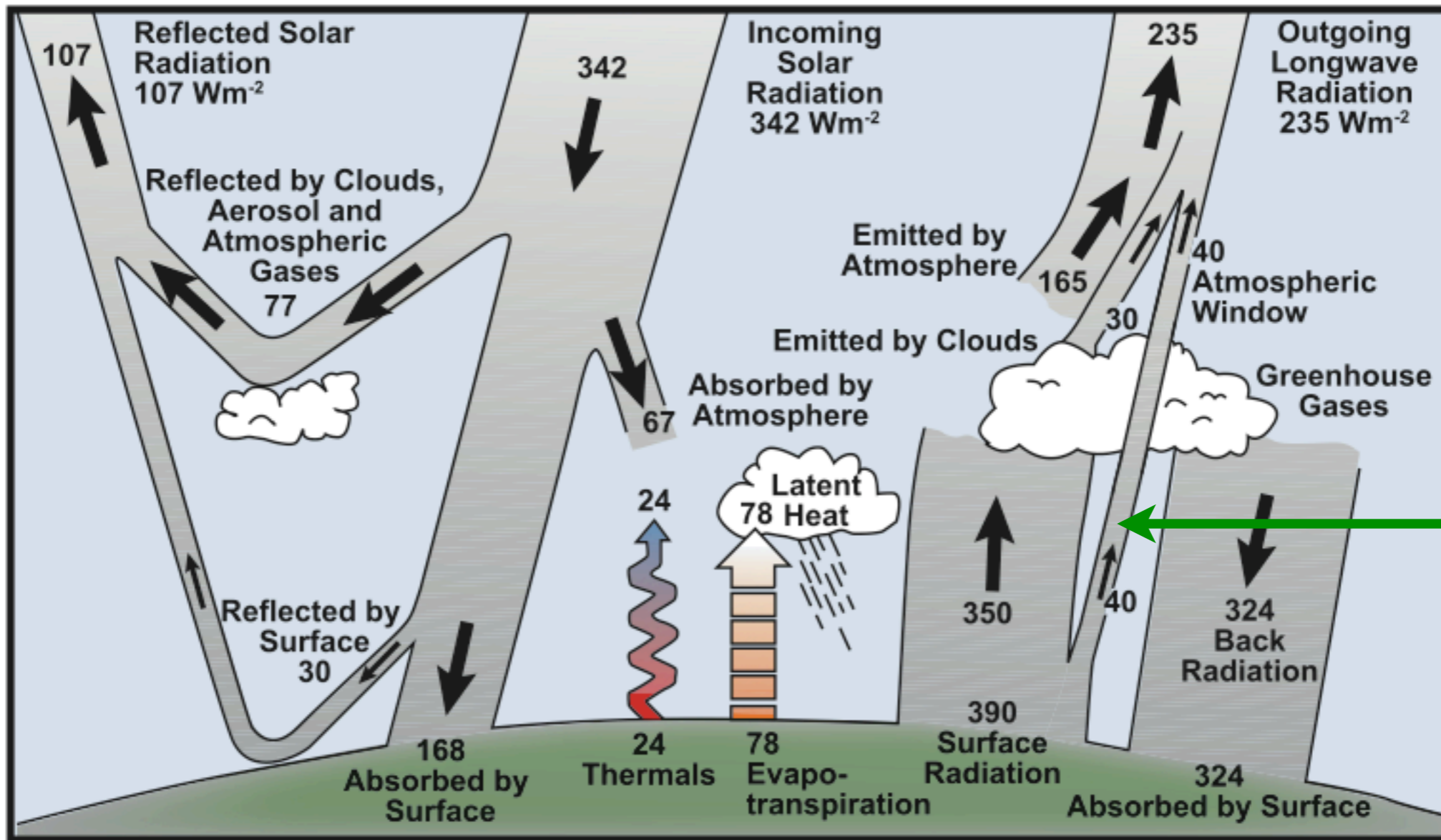

17% of IR out

**FAQ 1.1, Figure 1.** Estimate of the Earth's annual and global mean energy balance. Over the long term, the amount of incoming solar radiation absorbed by the Earth and atmosphere is balanced by the Earth and atmosphere releasing the same amount of outgoing longwave radiation. About half of the incoming solar radiation is absorbed by the Earth's surface. This energy is transferred to the atmosphere by warming the air in contact with the surface (thermals), by evapotranspiration and by longwave radiation that is absorbed by clouds and greenhouse gases. The atmosphere in turn radiates longwave energy back to Earth as well as out to space. Source: Kiehl and Trenberth (1997).

Also, the global mean includes the polar regions. By the way, the tropical cloud tops are colder than the polar regions.



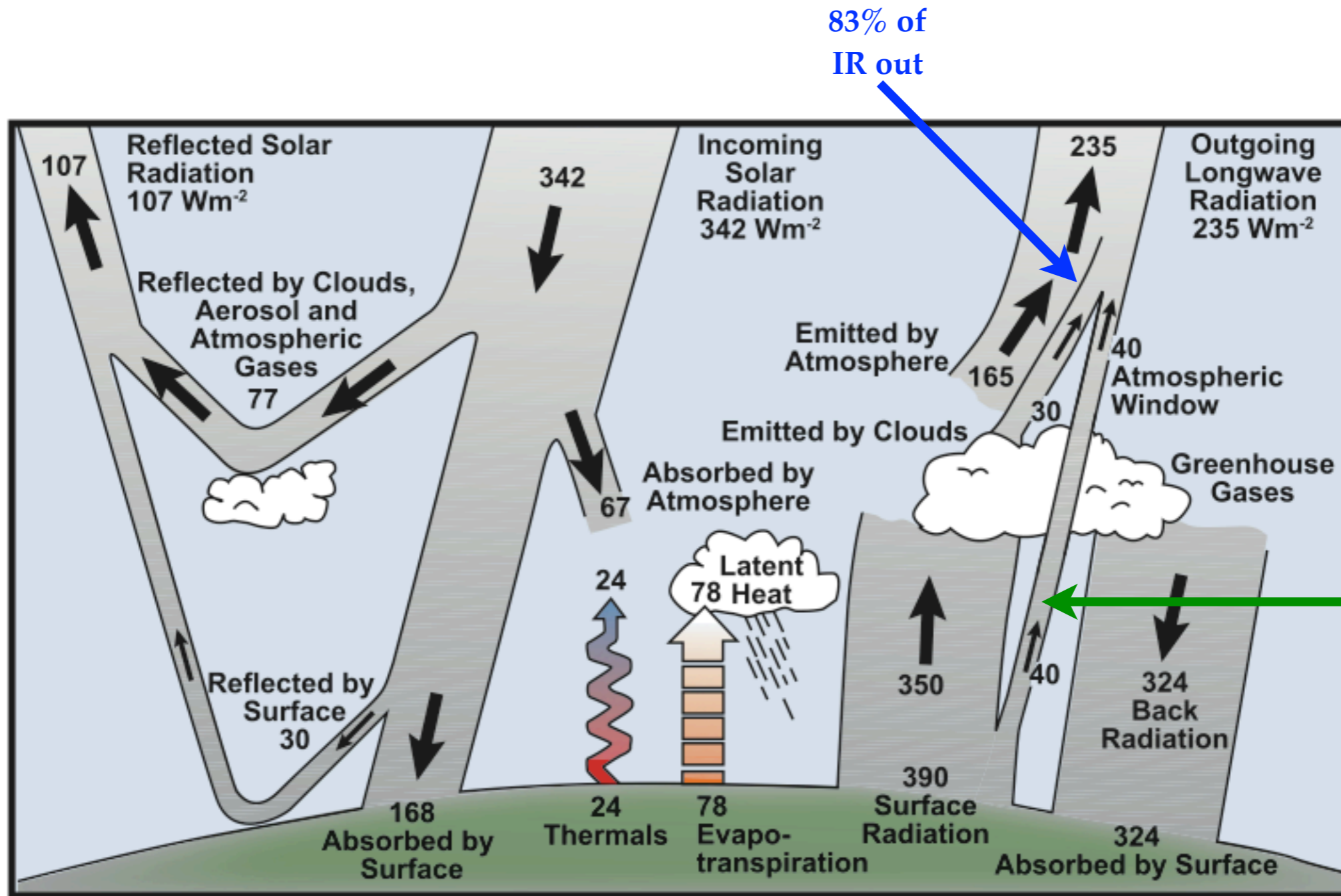

**FAQ 1.1, Figure 1.** Estimate of the Earth's annual and global mean energy balance. Over the long term, the amount of incoming solar radiation absorbed by the Earth and atmosphere is balanced by the Earth and atmosphere releasing the same amount of outgoing longwave radiation. About half of the incoming solar radiation is absorbed by the Earth's surface. This energy is transferred to the atmosphere by warming the air in contact with the surface (thermals), by evapotranspiration and by longwave radiation that is absorbed by clouds and greenhouse gases. The atmosphere in turn radiates longwave energy back to Earth as well as out to space. Source: Kiehl and Trenberth (1997).

17% of IR out

Also, the global mean includes the polar regions. By the way, the tropical cloud tops are colder than the polar regions.

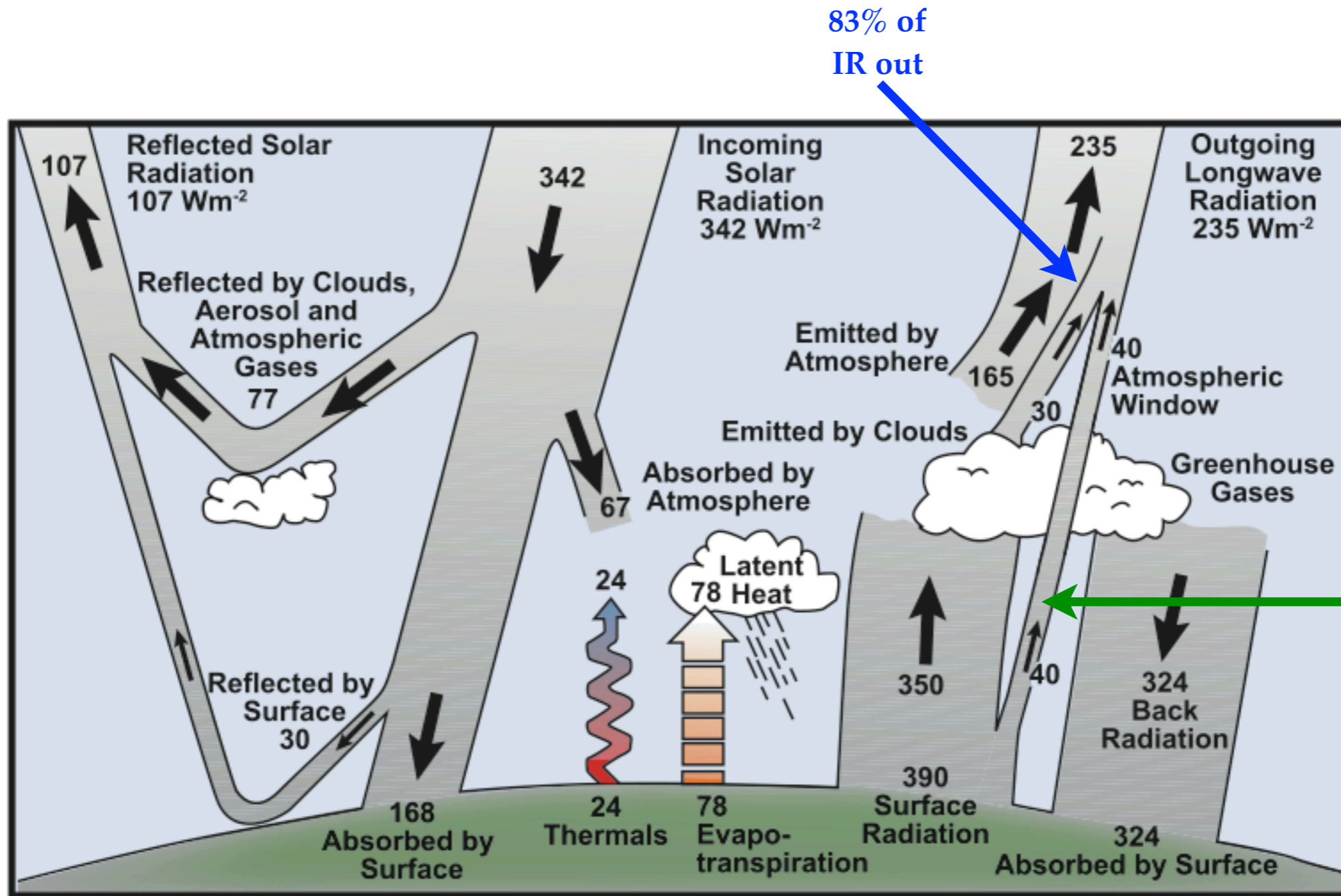

**FAQ 1.1, Figure 1.** Estimate of the Earth's annual and global mean energy balance. Over the long term, the amount of incoming solar radiation absorbed by the Earth and atmosphere is balanced by the Earth and atmosphere releasing the same amount of outgoing longwave radiation. About half of the incoming solar radiation is absorbed by the Earth's surface. This energy is transferred to the atmosphere by warming the air in contact with the surface (thermals), by evapotranspiration and by longwave radiation that is absorbed by clouds and greenhouse gases. The atmosphere in turn radiates longwave energy back to Earth as well as out to space. Source: Kiehl and Trenberth (1997).

When viewing the Earth from space in the infrared, you see mostly the atmosphere and clouds; the surface contributes but a small fraction. The atmosphere and clouds are much colder than the surface.

17% of IR out

Also, the global mean includes the polar regions. By the way, the tropical cloud tops are colder than the polar regions.



This component is the albedo.  
 72% is from the atmosphere.  
 28% is from the surface.

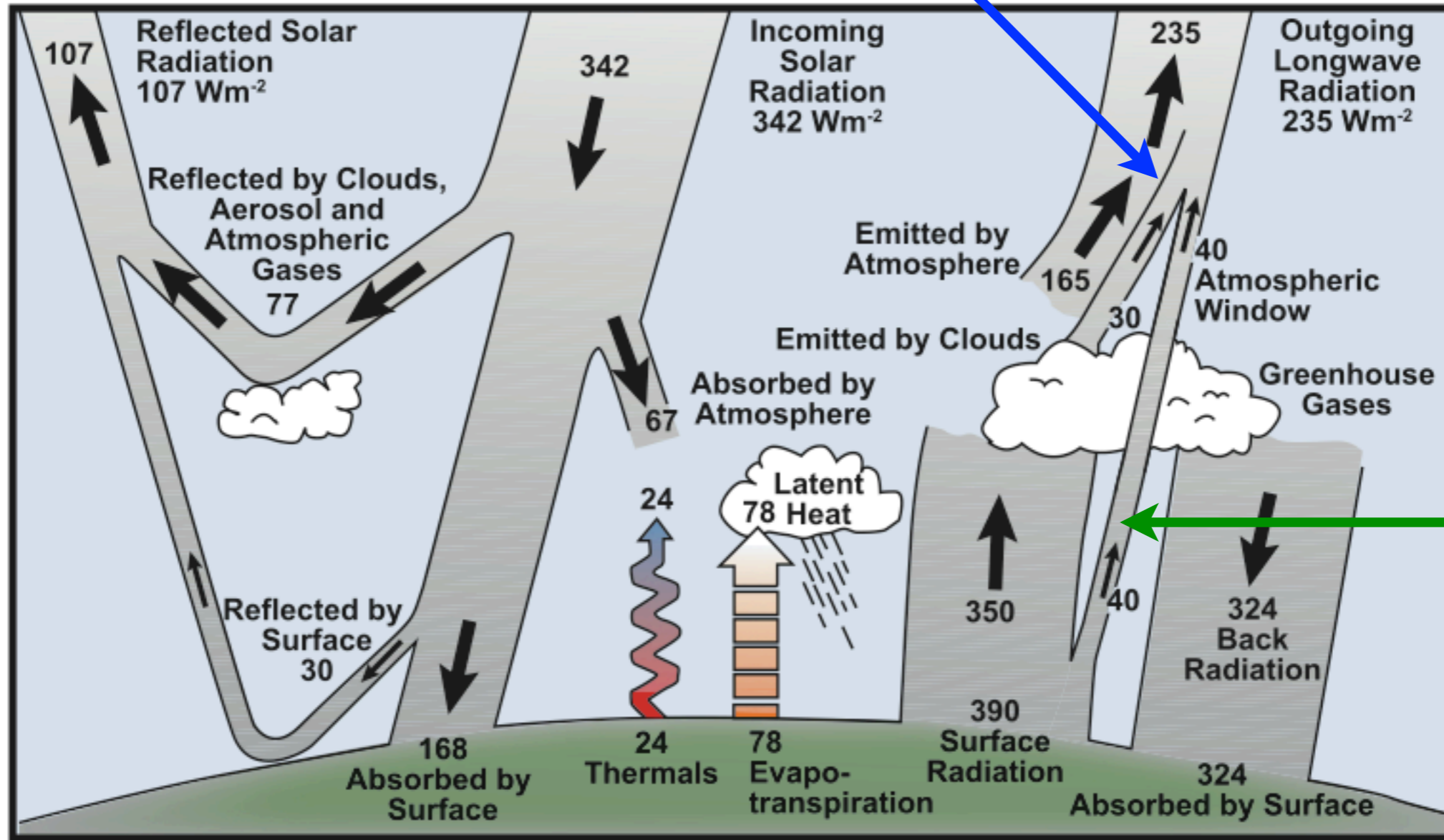

83% of IR out

17% of IR out

**FAQ 1.1, Figure 1.** Estimate of the Earth's annual and global mean energy balance. Over the long term, the amount of incoming solar radiation absorbed by the Earth and atmosphere is balanced by the Earth and atmosphere releasing the same amount of outgoing longwave radiation. About half of the incoming solar radiation is absorbed by the Earth's surface. This energy is transferred to the atmosphere by warming the air in contact with the surface (thermals), by evapotranspiration and by longwave radiation that is absorbed by clouds and greenhouse gases. The atmosphere in turn radiates longwave energy back to Earth as well as out to space. Source: Kiehl and Trenberth (1997).

Also, the global mean includes the polar regions. By the way, the tropical cloud tops are colder than the polar regions.

When viewing the Earth from space in the infrared, you see mostly the atmosphere and clouds; the surface contributes but a small fraction. The atmosphere and clouds are much colder than the surface.

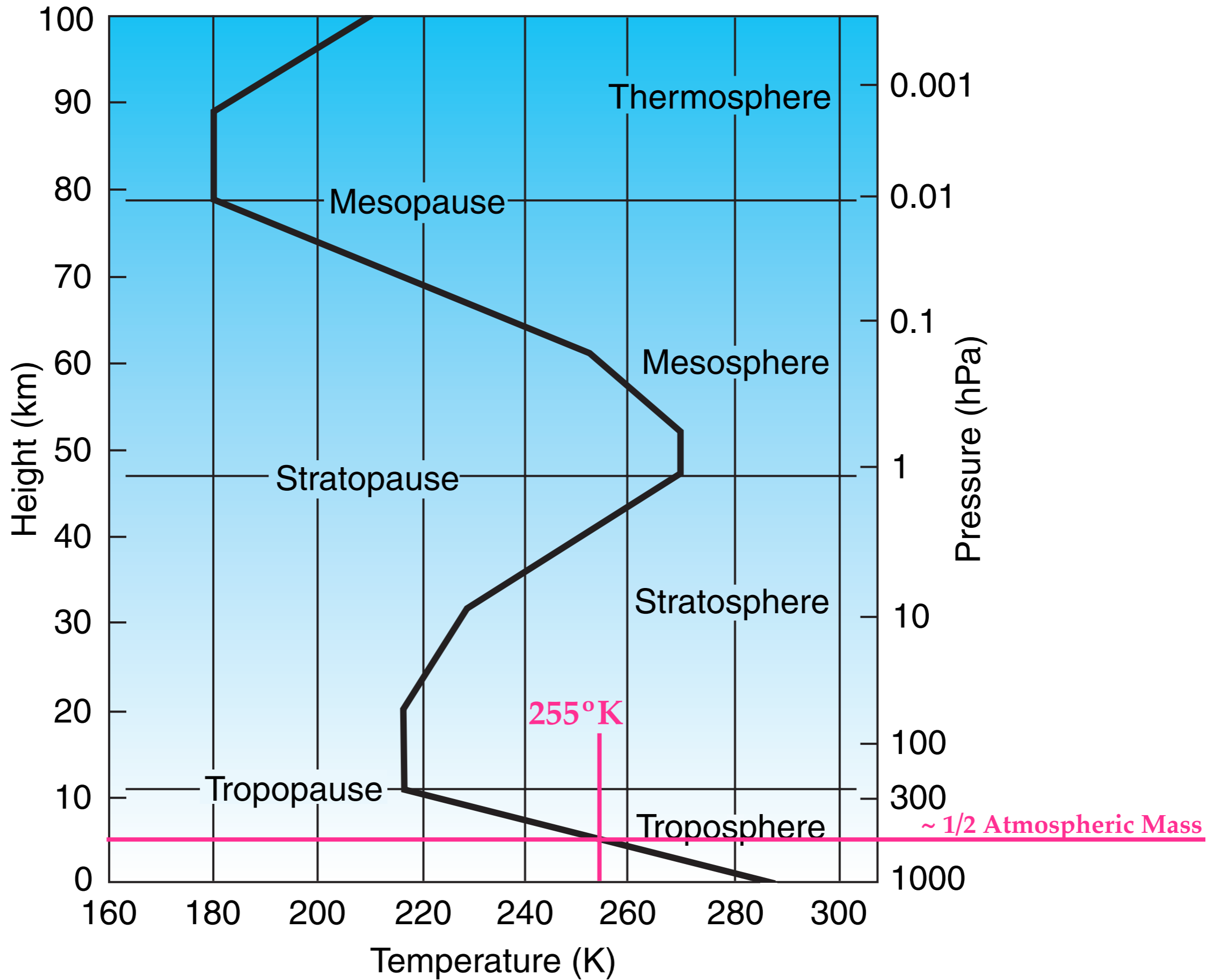



# This is how it works.

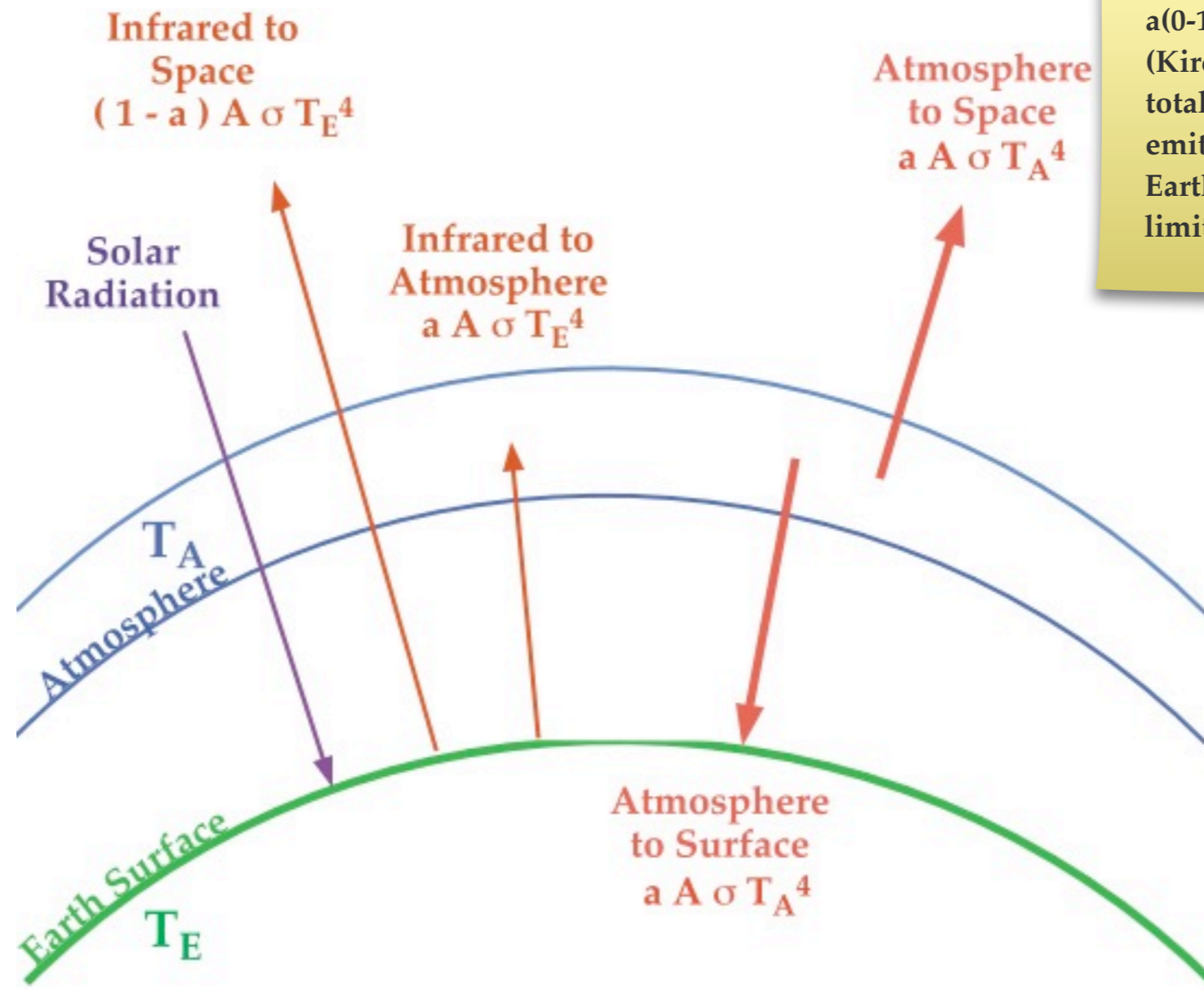

$a(0-1)$  = absorbtivity = emissivity (Kirchhoff's Law): the fraction of the total radiation that is absorbed or emitted.  
Earth now:  $a = 0.766$  close to the upper limit for a 1-layer atmosphere.

# This is how it works.

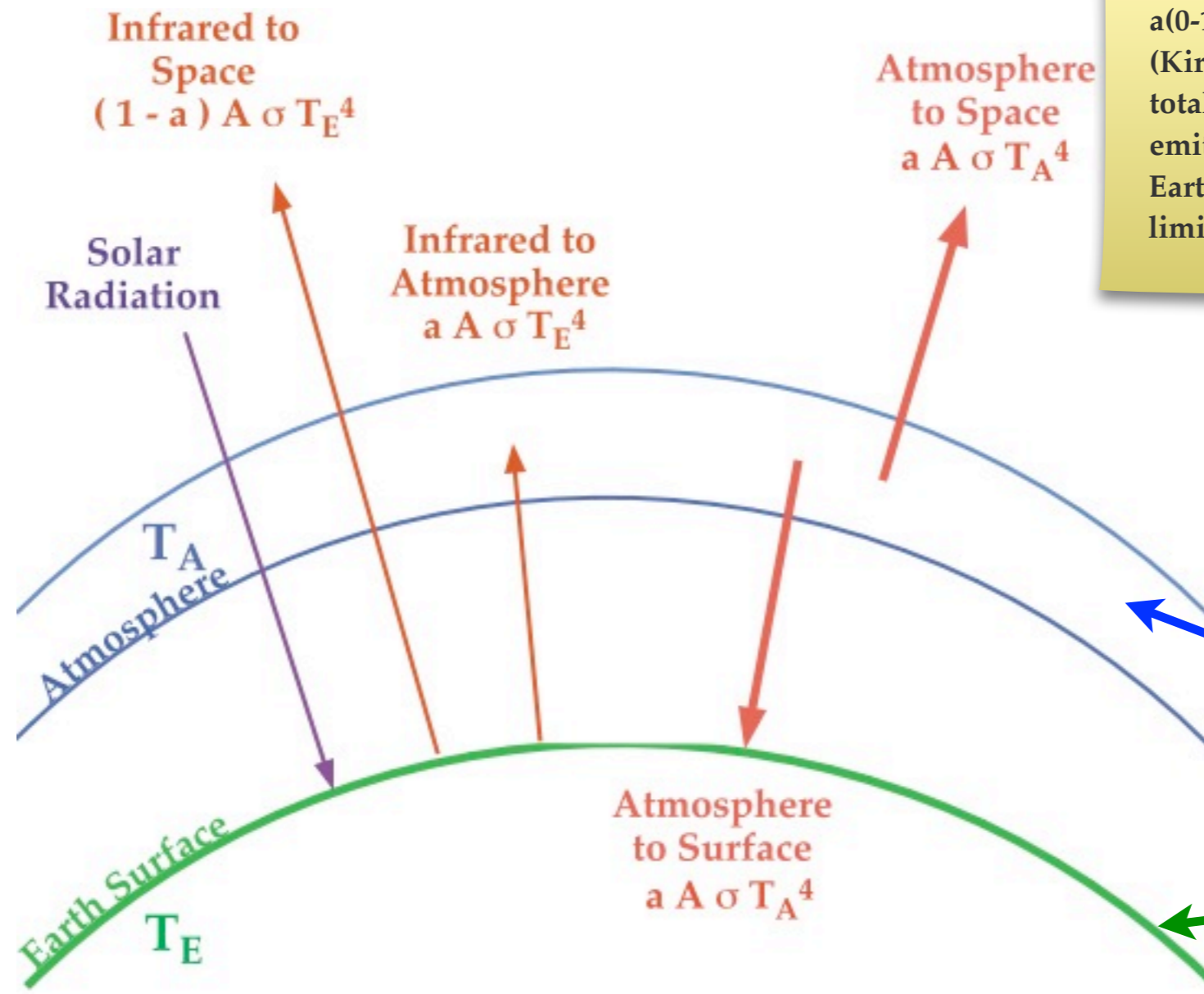

$a(0-1)$  = absorbtivity = emissivity (Kirchhoff's Law): the fraction of the total radiation that is absorbed or emitted.  
Earth now:  $a = 0.766$  close to the upper limit for a 1-layer atmosphere.

The atmosphere is depicted as a layer above the Earth's surface.

# This is how it works.

$a(0-1)$  = absorbtivity = emissivity (Kirchhoff's Law): the fraction of the total radiation that is absorbed or emitted.  
Earth now:  $a = 0.766$  close to the upper limit for a 1-layer atmosphere.

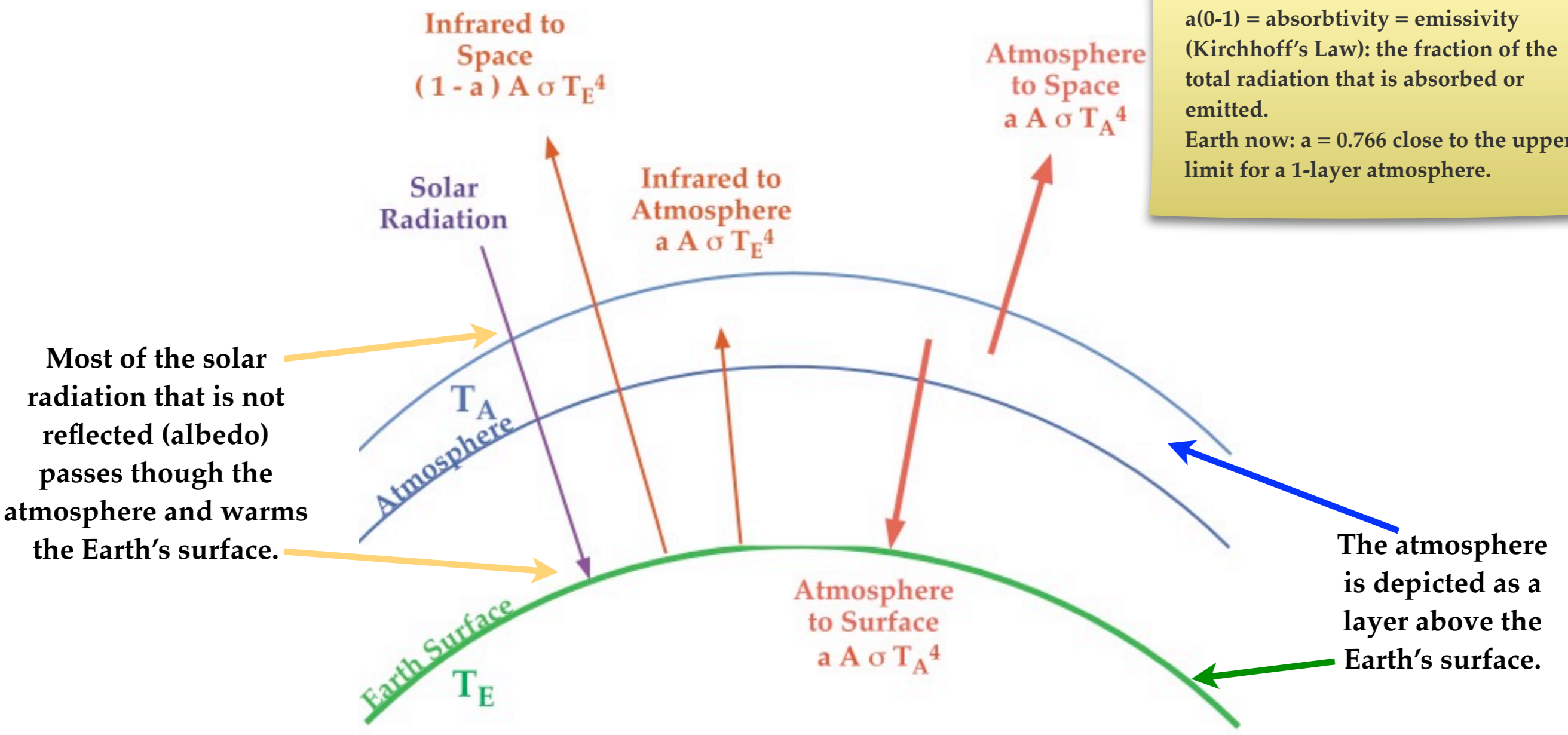

Most of the solar radiation that is not reflected (albedo) passes through the atmosphere and warms the Earth's surface.

The atmosphere is depicted as a layer above the Earth's surface.

# This is how it works.

$a(0-1)$  = absorbtivity = emissivity (Kirchhoff's Law): the fraction of the total radiation that is absorbed or emitted.  
Earth now:  $a = 0.766$  close to the upper limit for a 1-layer atmosphere.

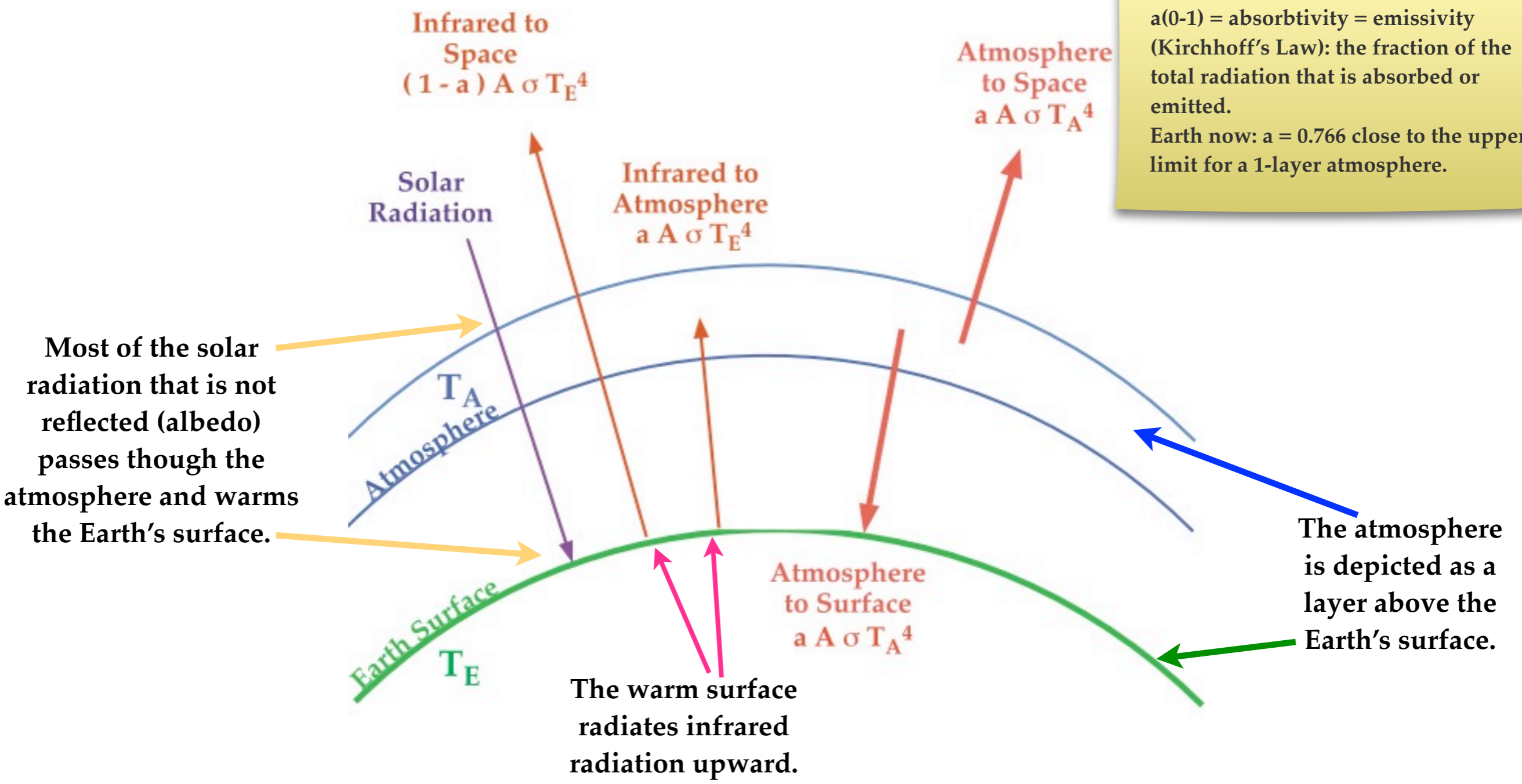



# This is how it works.

$a(0-1)$  = absorbtivity = emissivity (Kirchhoff's Law): the fraction of the total radiation that is absorbed or emitted.  
Earth now:  $a = 0.766$  close to the upper limit for a 1-layer atmosphere.

A small fraction of the surface radiation passes through the atmosphere to space.

Infrared to Space  
 $(1 - a) A \sigma T_E^4$

Atmosphere to Space  
 $a A \sigma T_A^4$

Solar Radiation

Infrared to Atmosphere  
 $a A \sigma T_E^4$

$T_A$   
Atmosphere

Most of the solar radiation that is not reflected (albedo) passes through the atmosphere and warms the Earth's surface.

Atmosphere to Surface  
 $a A \sigma T_A^4$

Earth Surface  
 $T_E$

The warm surface radiates infrared radiation upward.

The atmosphere is depicted as a layer above the Earth's surface.

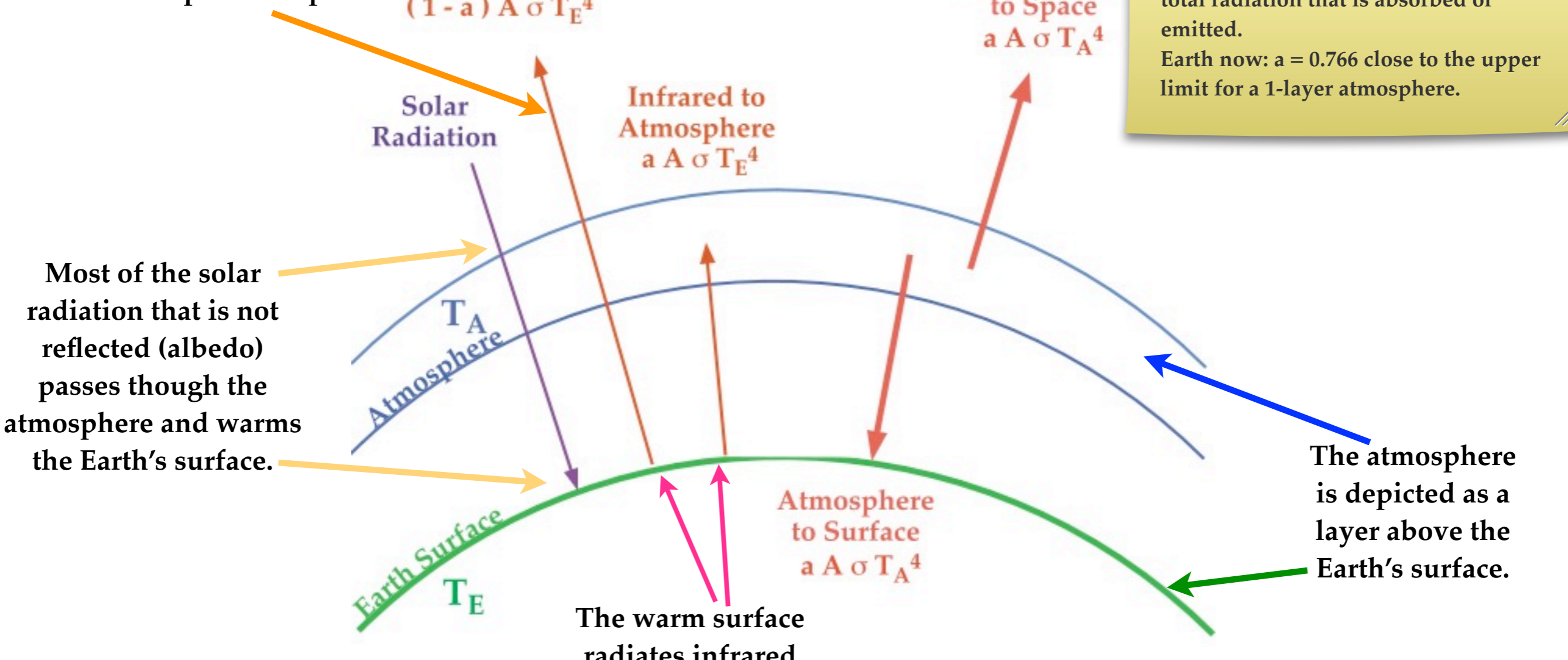

# This is how it works.

$a(0-1)$  = absorbtivity = emissivity (Kirchhoff's Law): the fraction of the total radiation that is absorbed or emitted.  
Earth now:  $a = 0.766$  close to the upper limit for a 1-layer atmosphere.

A small fraction of the surface radiation passes through the atmosphere to space.

Most of the surface radiation is absorbed in the atmosphere and warms the atmosphere.

Most of the solar radiation that is not reflected (albedo) passes through the atmosphere and warms the Earth's surface.

The warm surface radiates infrared radiation upward.

The atmosphere is depicted as a layer above the Earth's surface.

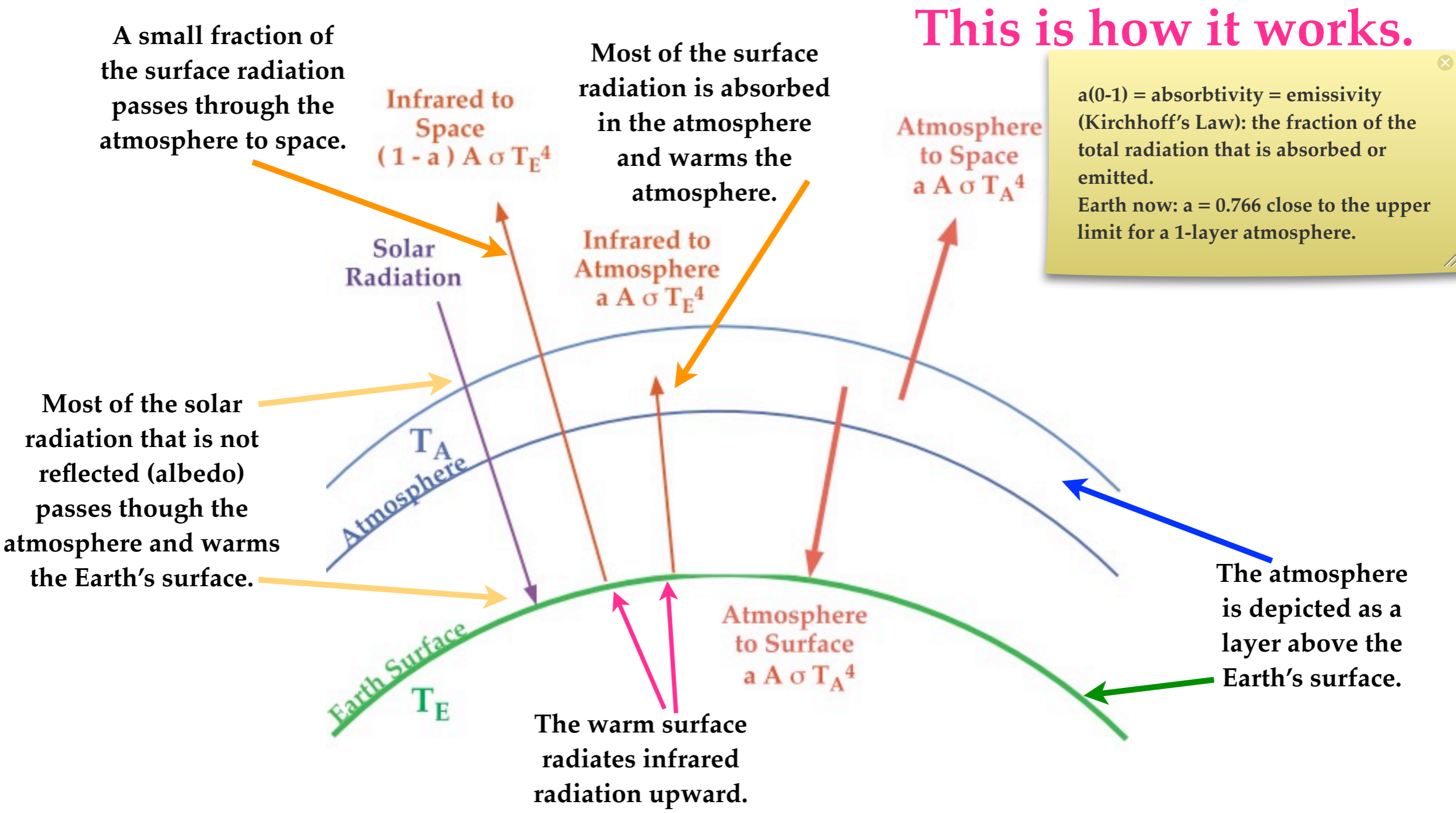

# This is how it works.

$a(0-1)$  = absorbtivity = emissivity (Kirchhoff's Law): the fraction of the total radiation that is absorbed or emitted.  
Earth now:  $a = 0.766$  close to the upper limit for a 1-layer atmosphere.

A small fraction of the surface radiation passes through the atmosphere to space.

Most of the surface radiation is absorbed in the atmosphere and warms the atmosphere.

Atmosphere to Space  
 $a A \sigma T_A^4$

Infrared to Space  
 $(1 - a) A \sigma T_E^4$

Infrared to Atmosphere  
 $a A \sigma T_E^4$

The warmed atmosphere radiates upward to space and downward to the surface.

Most of the solar radiation that is not reflected (albedo) passes through the atmosphere and warms the Earth's surface.

Solar Radiation

$T_A$   
Atmosphere

Earth Surface  
 $T_E$

Atmosphere to Surface  
 $a A \sigma T_A^4$

The warm surface radiates infrared radiation upward.

The atmosphere is depicted as a layer above the Earth's surface.

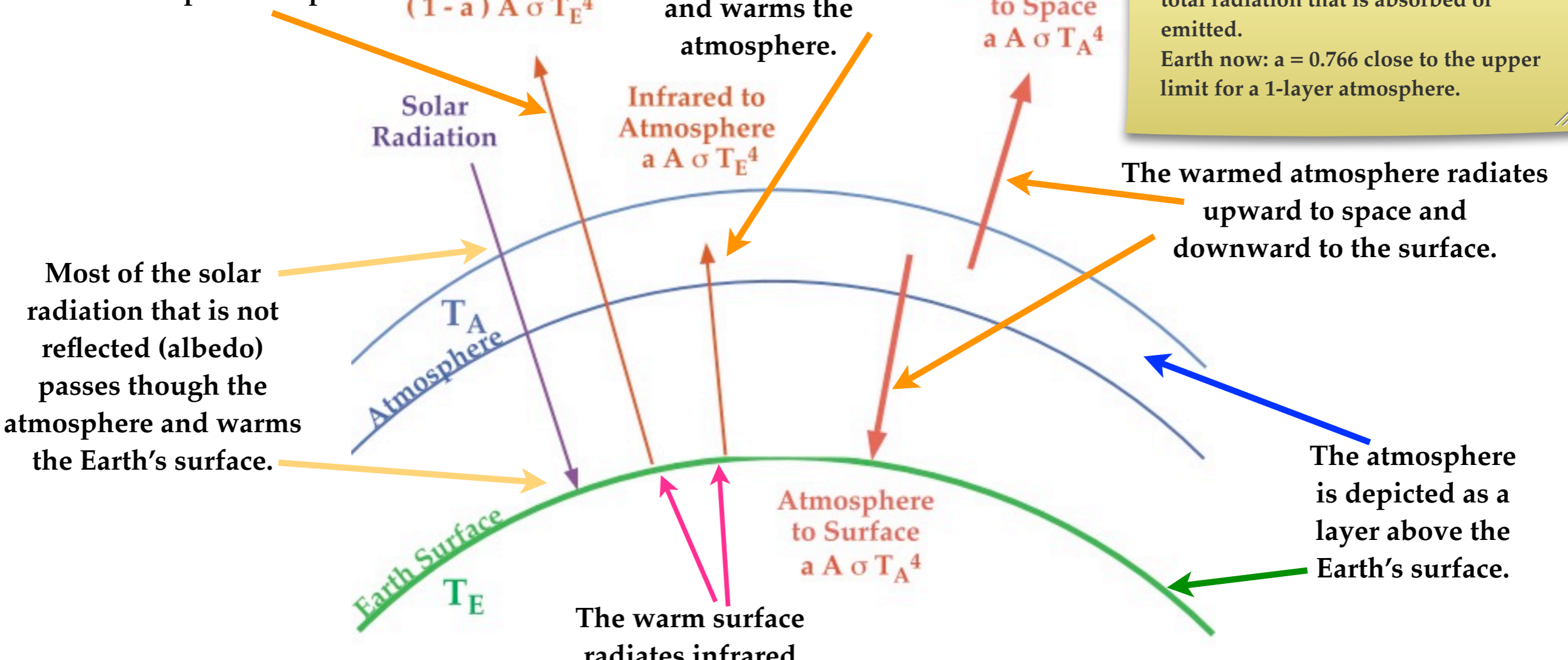



# This is how it works.

$a(0-1)$  = absorbtivity = emissivity (Kirchhoff's Law): the fraction of the total radiation that is absorbed or emitted.  
Earth now:  $a = 0.766$  close to the upper limit for a 1-layer atmosphere.

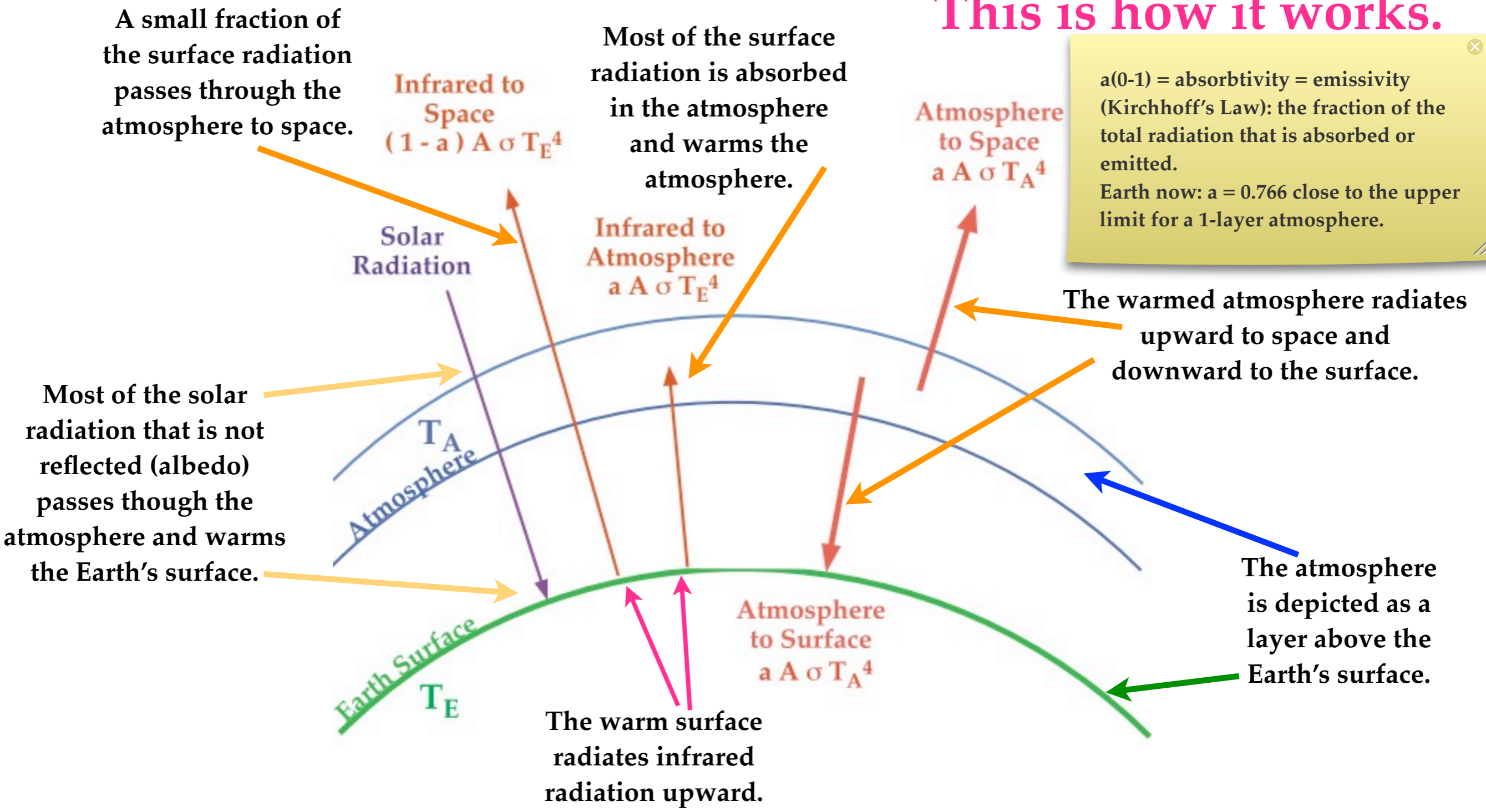

The final result of this interaction of the atmosphere with the upward and downward radiation is that the surface is warmed by both the Sun and the atmosphere. This is global warming. When the greenhouse gasses increase, the warming increases - the law of radiation transfer. This result is unavoidable.

The next step is to use a multilevel model for an atmosphere. Current large numerical models for Earth use at least 15 layers. Consider the 2-layer model here.

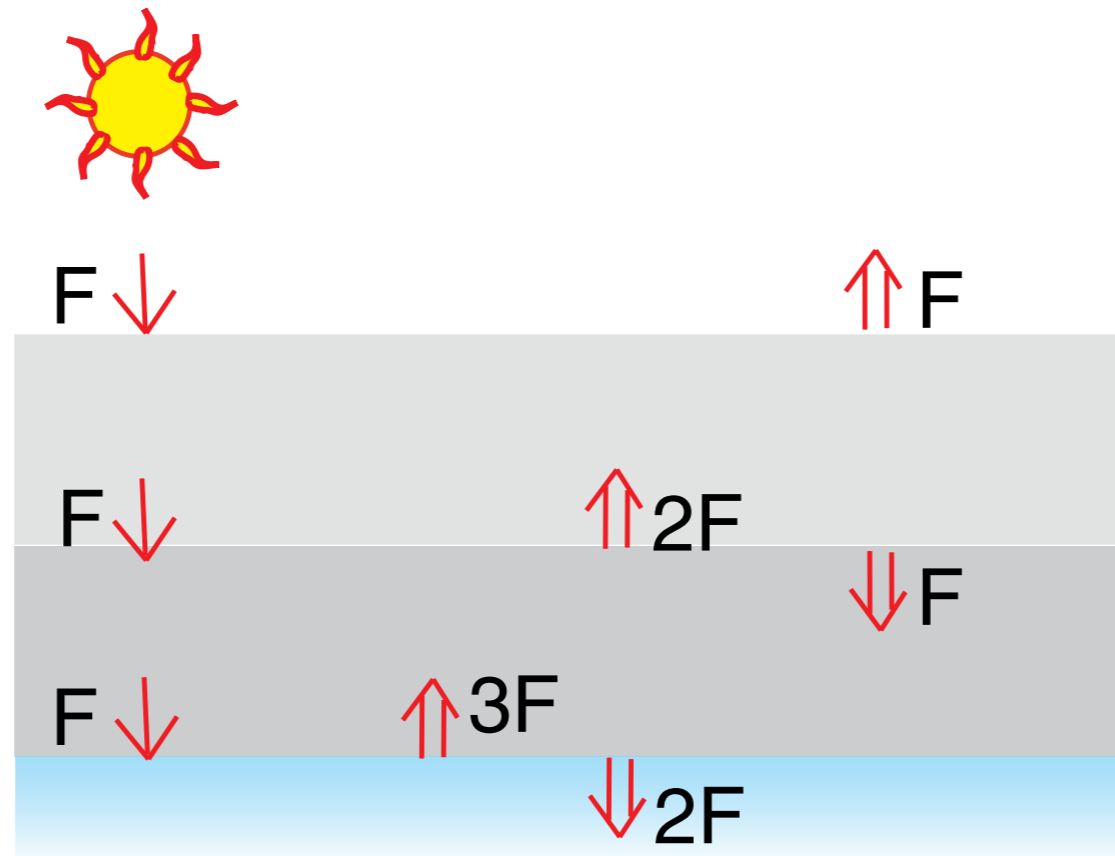

Venus:  $A=0.75$   $T_E=232K$   
Earth:  $A=0.30$   $T_E= 255K$   
Venus:  $T_S=737K$   
Earth:  $T_S= 288K$   
Greenhouse  $V = 505K$ ( or C)  
Greenhouse  $E = 33K$  (or C)  
Using the simple model on this slide for Venus requires 19 layers of atmospheres!

Simplified greenhouse model of two internally isothermal atmospheric layers but with different temperatures. The upward and downward fluxes at each level must be equal. Start at the top level; one  $F$  down must be matched by one  $F$  up. Each layer must radiate the same flux down that it radiates up; thus the top layer radiates one  $F$  down. Now there are two  $F$ s down into the bottom layer, which must be matched by two  $F$ s up and down. This makes three  $F$ s down to the surface, which must radiate three  $F$ s up. The temperature must increase downward because the lower layers must radiate more flux than the higher layers.

The next step is to use a multilevel model for an atmosphere. Current large numerical models for Earth use at least 15 layers. Consider the 2-layer model here.

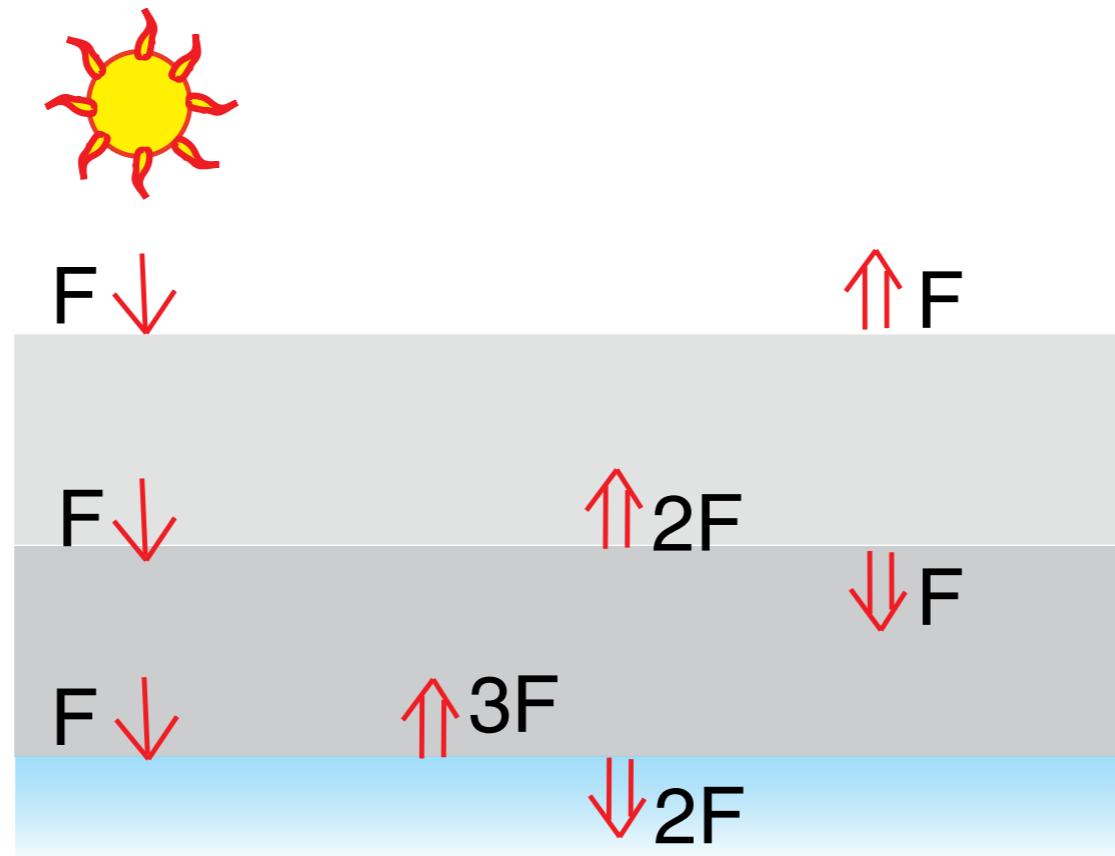

Venus:  $A=0.75$   $T_E=232K$   
 Earth:  $A=0.30$   $T_E= 255K$   
 Venus:  $T_S=737K$   
 Earth:  $T_S= 288K$   
 Greenhouse  $V = 505K$ ( or C)  
 Greenhouse  $E = 33K$  (or C)  
 Using the simple model on this slide for Venus requires 19 layers of atmospheres!

Simplified greenhouse model of two internally isothermal atmospheric layers but with different temperatures. The upward and downward fluxes at each level must be equal. Start at the top level; one  $F$  down must be matched by one  $F$  up. Each layer must radiate the same flux down that it radiates up; thus the top layer radiates one  $F$  down. Now there are two  $F$ s down into the bottom layer, which must be matched by two  $F$ s up and down. This makes three  $F$ s down to the surface, which must radiate three  $F$ s up. The temperature must increase downward because the lower layers must radiate more flux than the higher layers.

**In this model of surface warming, adding greenhouse gasses is analogous to adding layers to this model.**



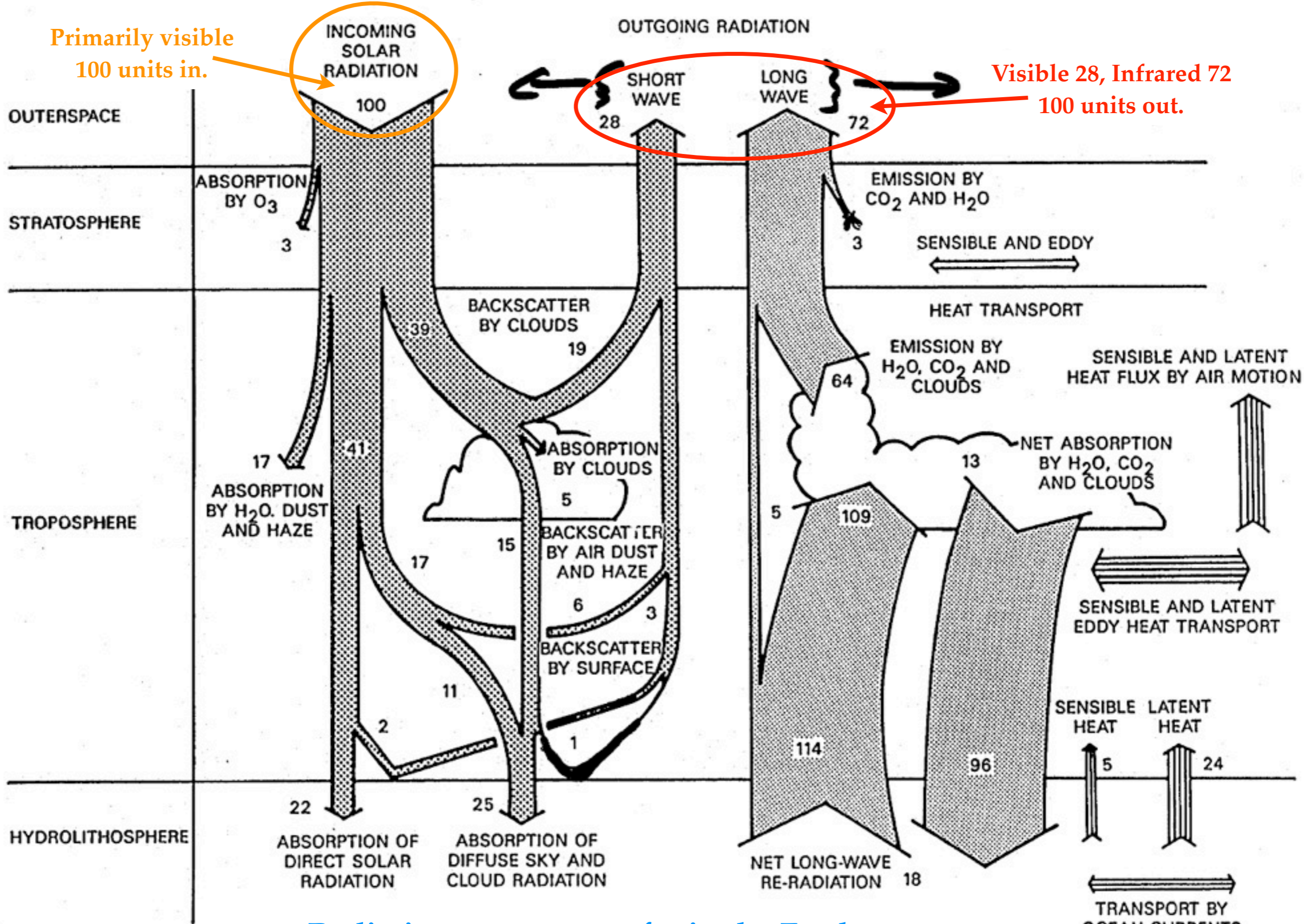

Radiation energy transfer in the Earth system; short wave (visible) and long wave (infrared).



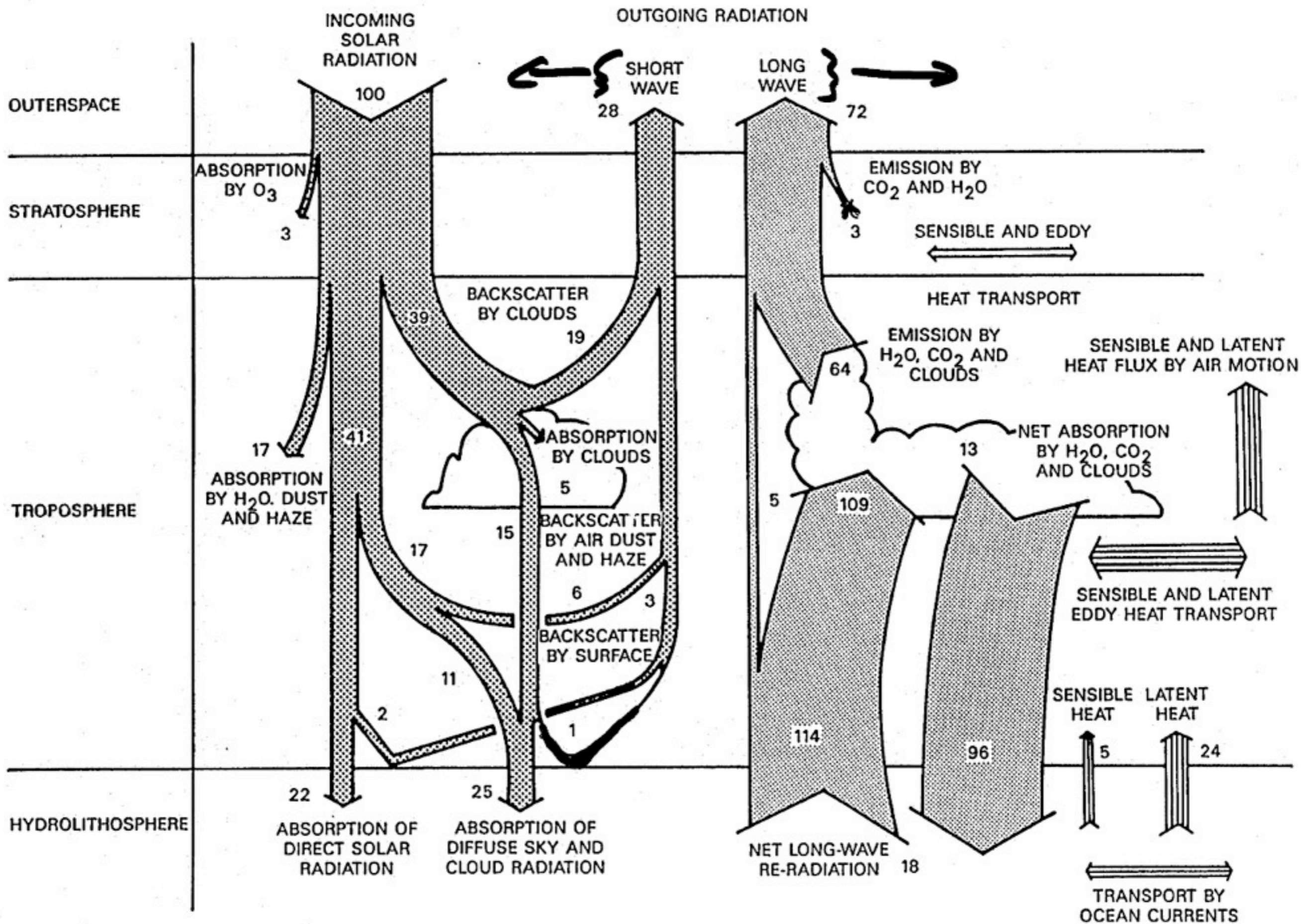

Figure 12. Schematic diagram of the disposition of absorbed solar energy in the Earth system.



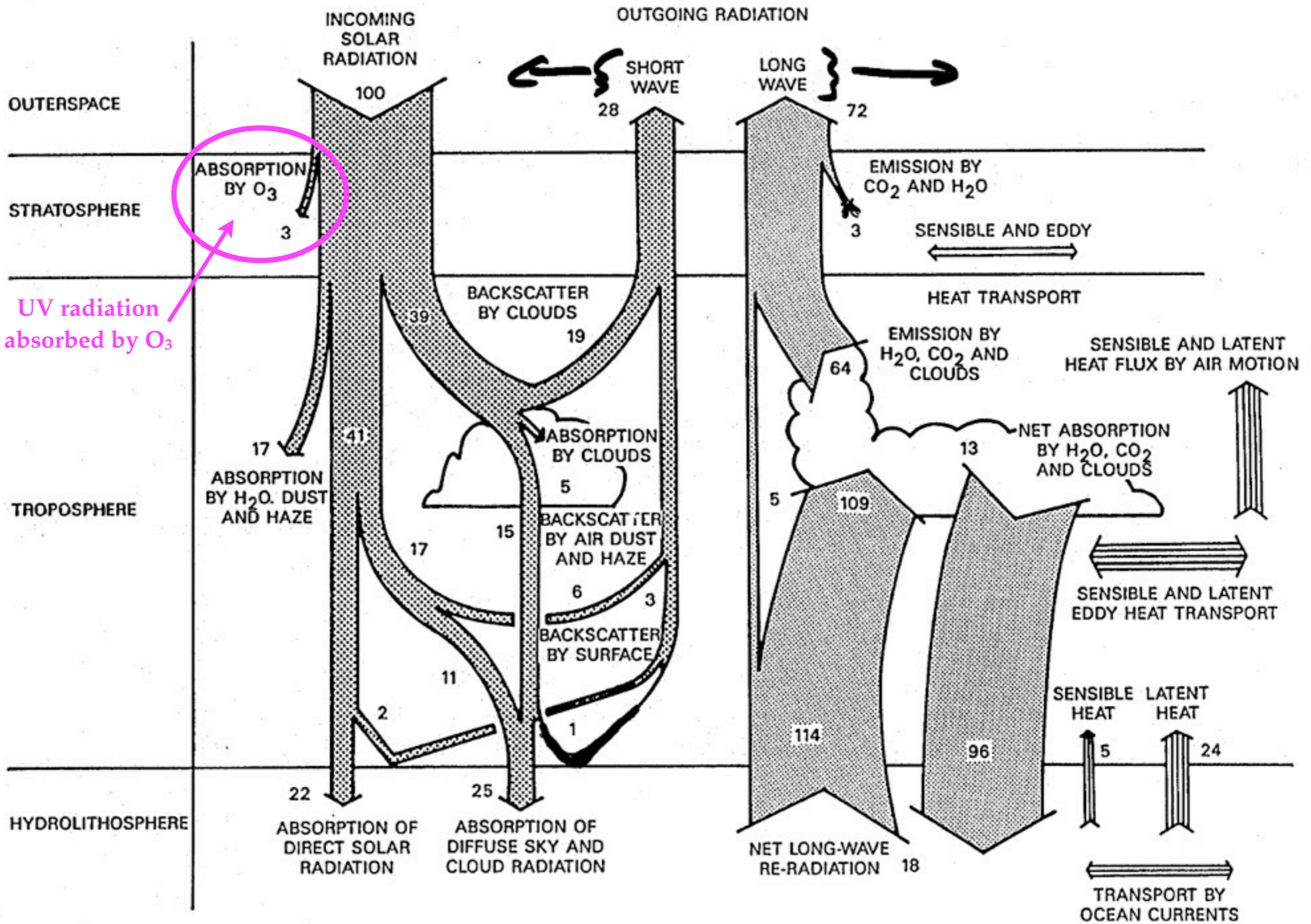

Figure 12. Schematic diagram of the disposition of absorbed solar energy in the Earth system.



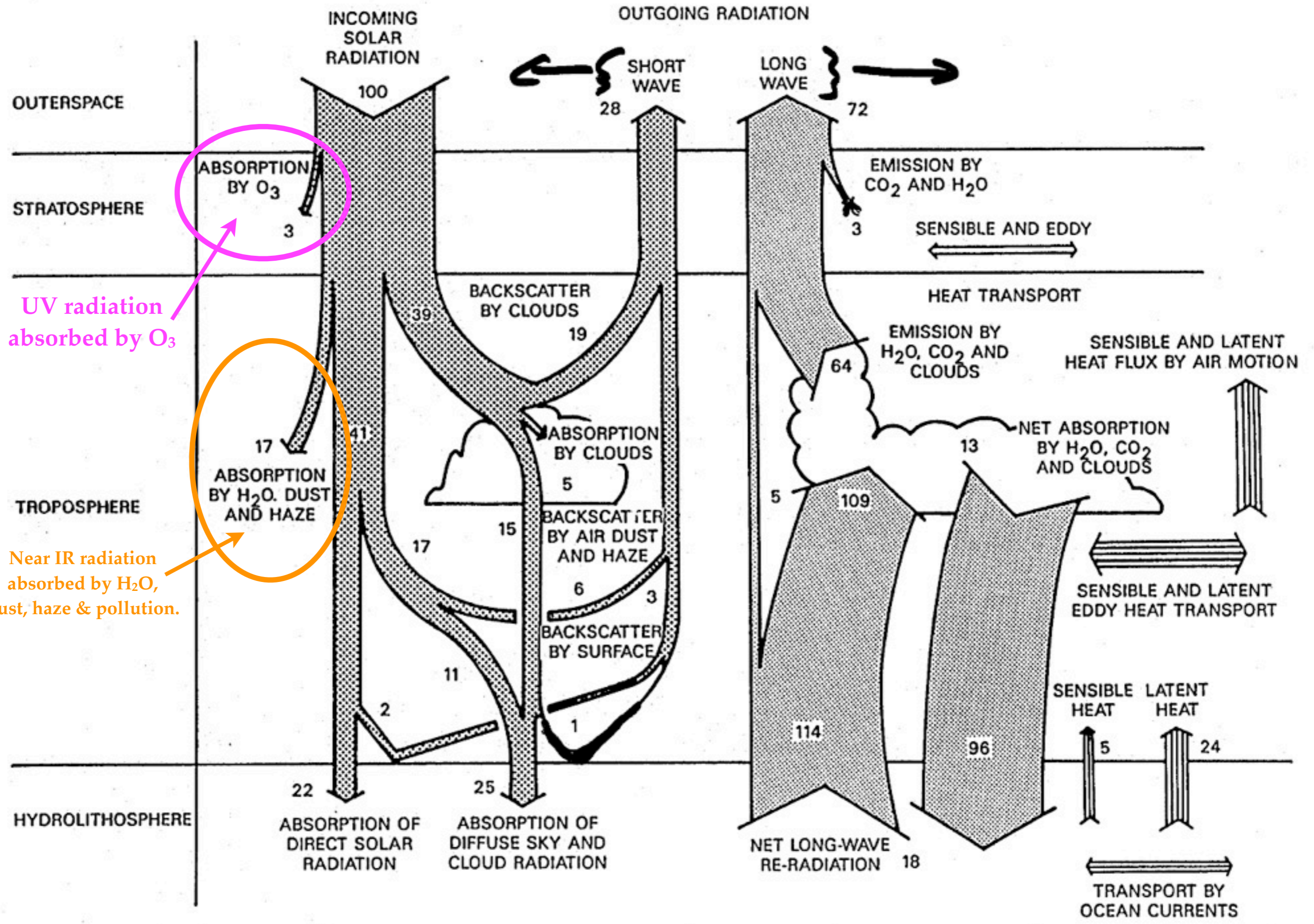

Figure 12. Schematic diagram of the disposition of absorbed solar energy in the Earth system.



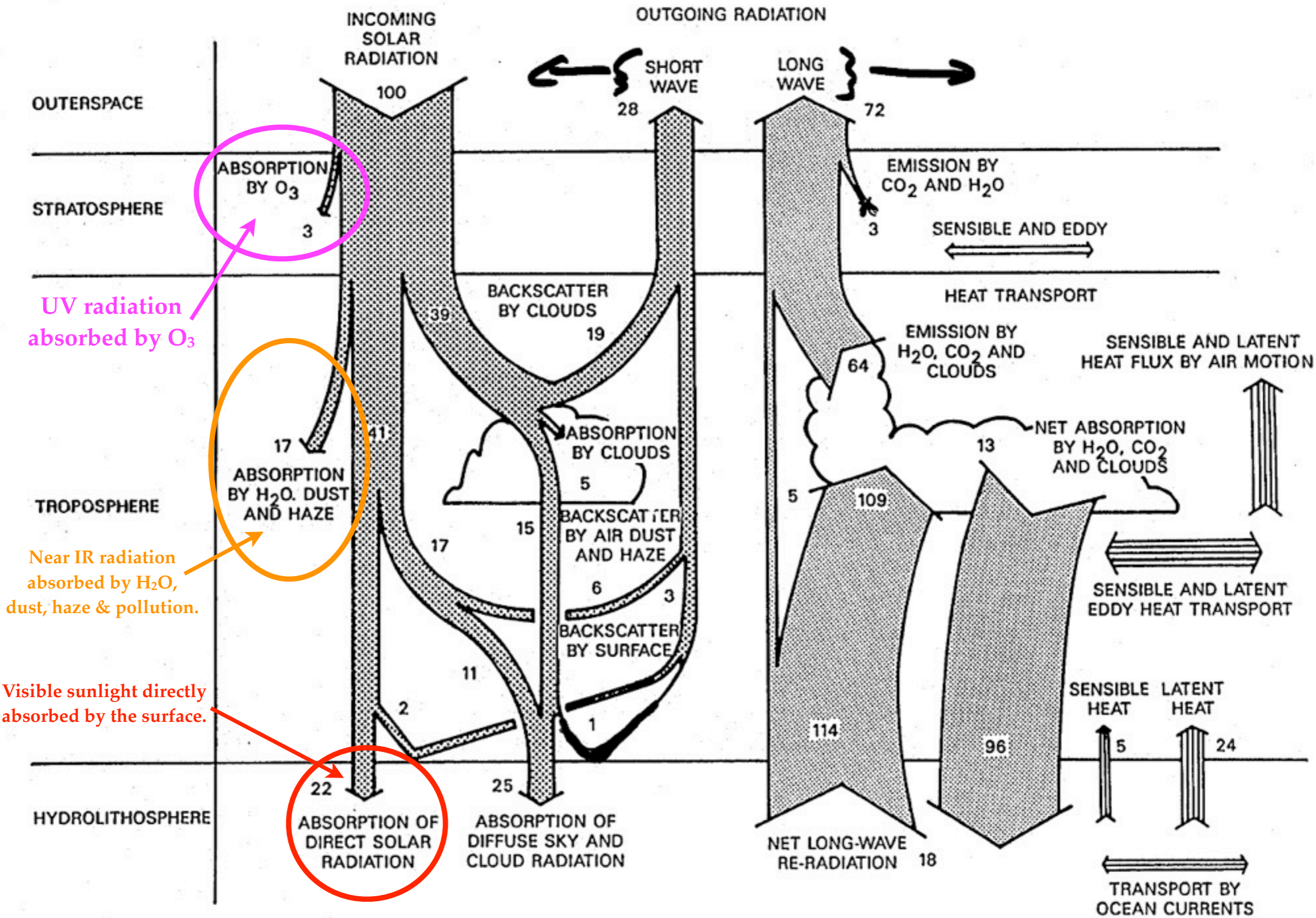

Figure 12. Schematic diagram of the disposition of absorbed solar energy in the Earth system.



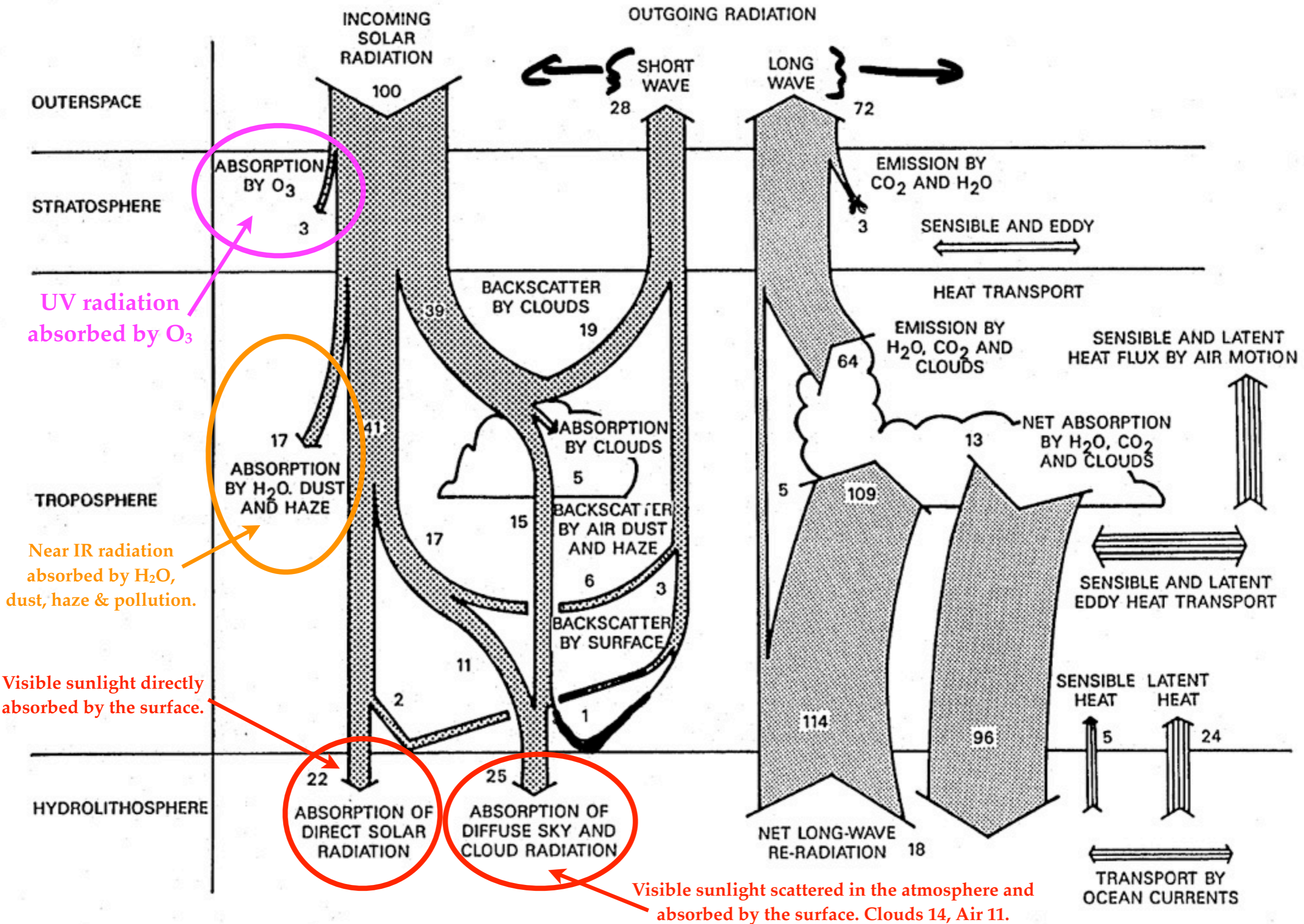

Figure 12. Schematic diagram of the disposition of absorbed solar energy in the Earth system.



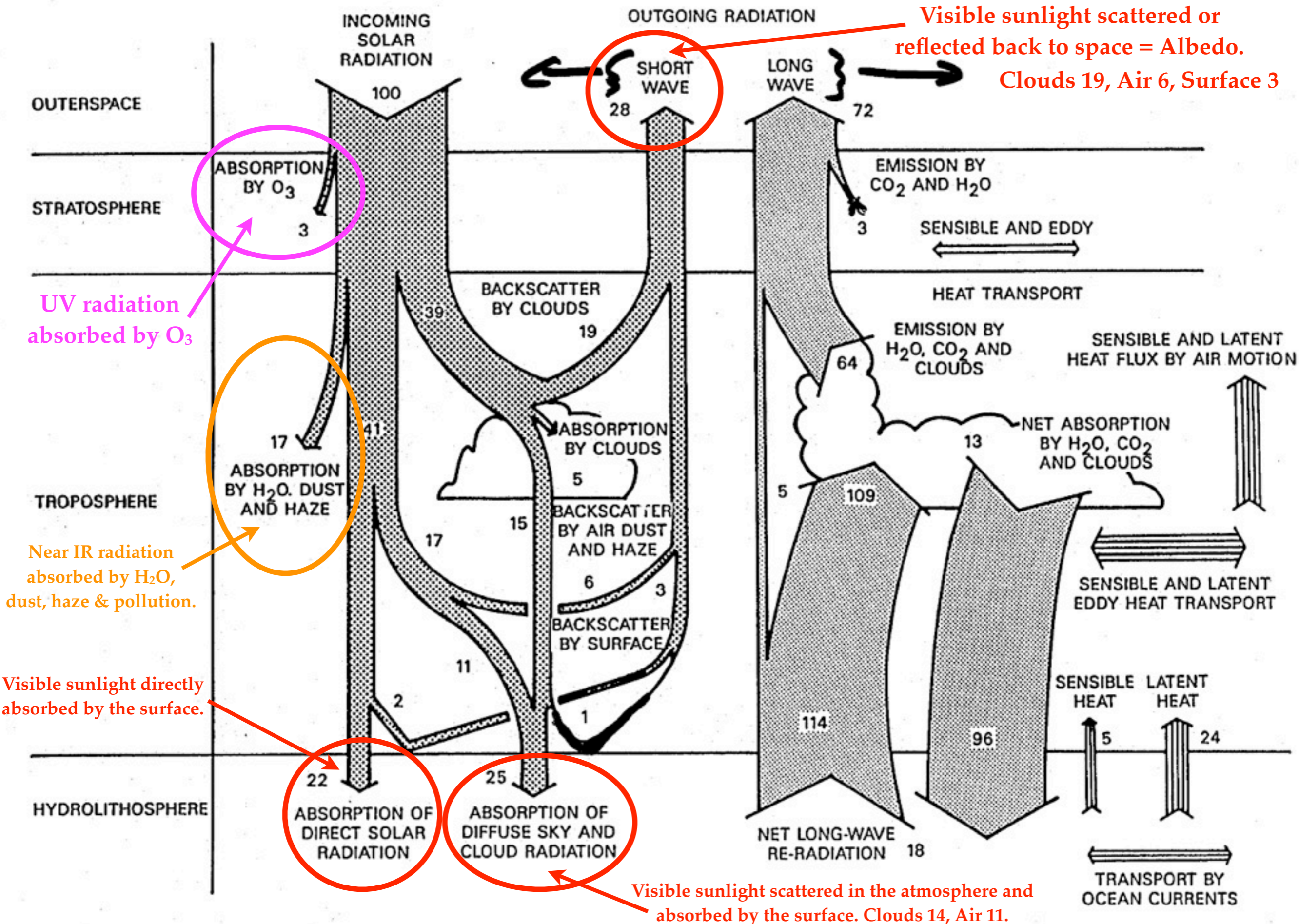

Figure 12. Schematic diagram of the disposition of absorbed solar energy in the Earth system.

When the Earth is viewed from space in visible radiation,  
we mostly see clouds (19 units, white)  
and air (6 units, blue);  
least is the surface (3 units, various colors).



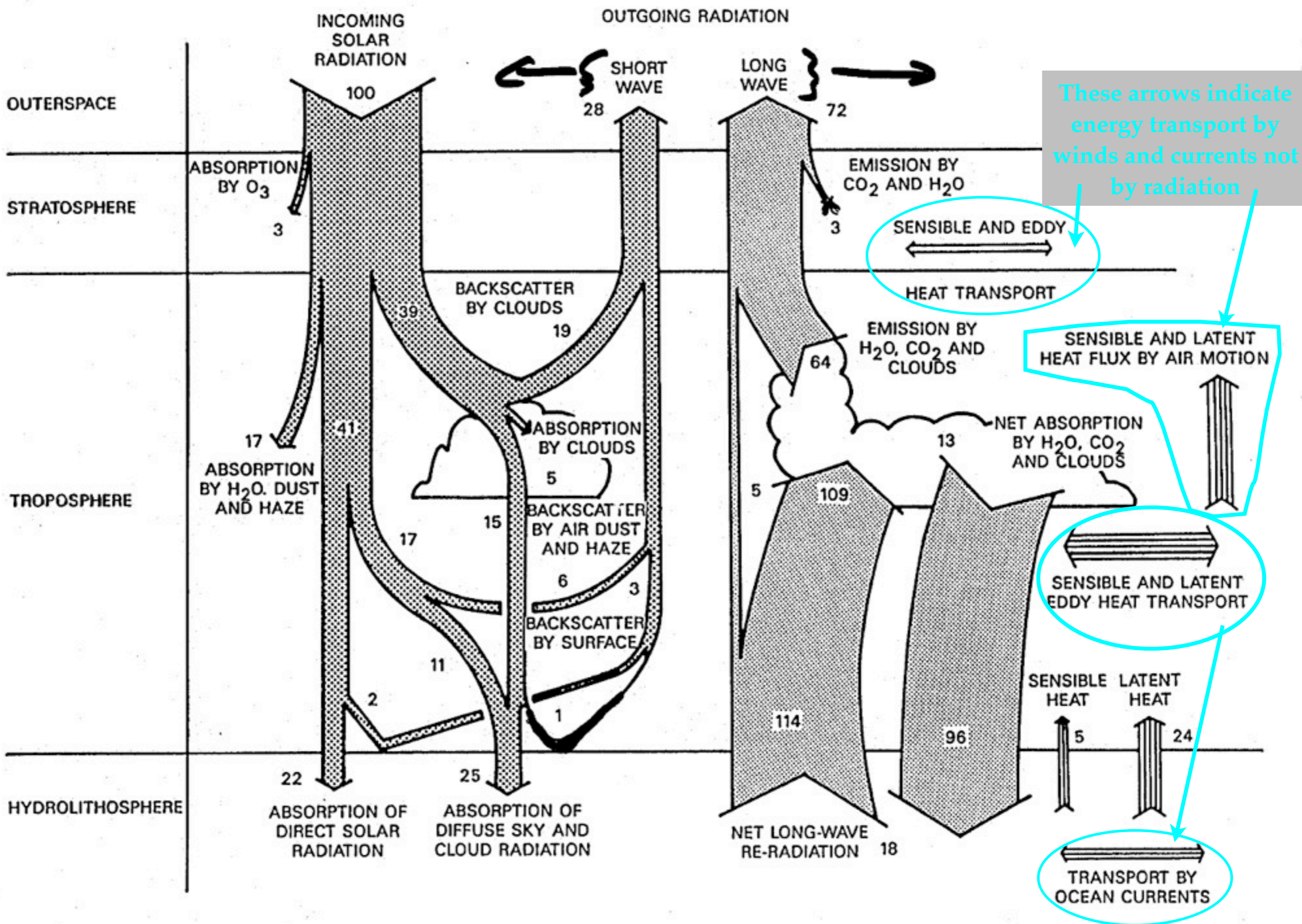
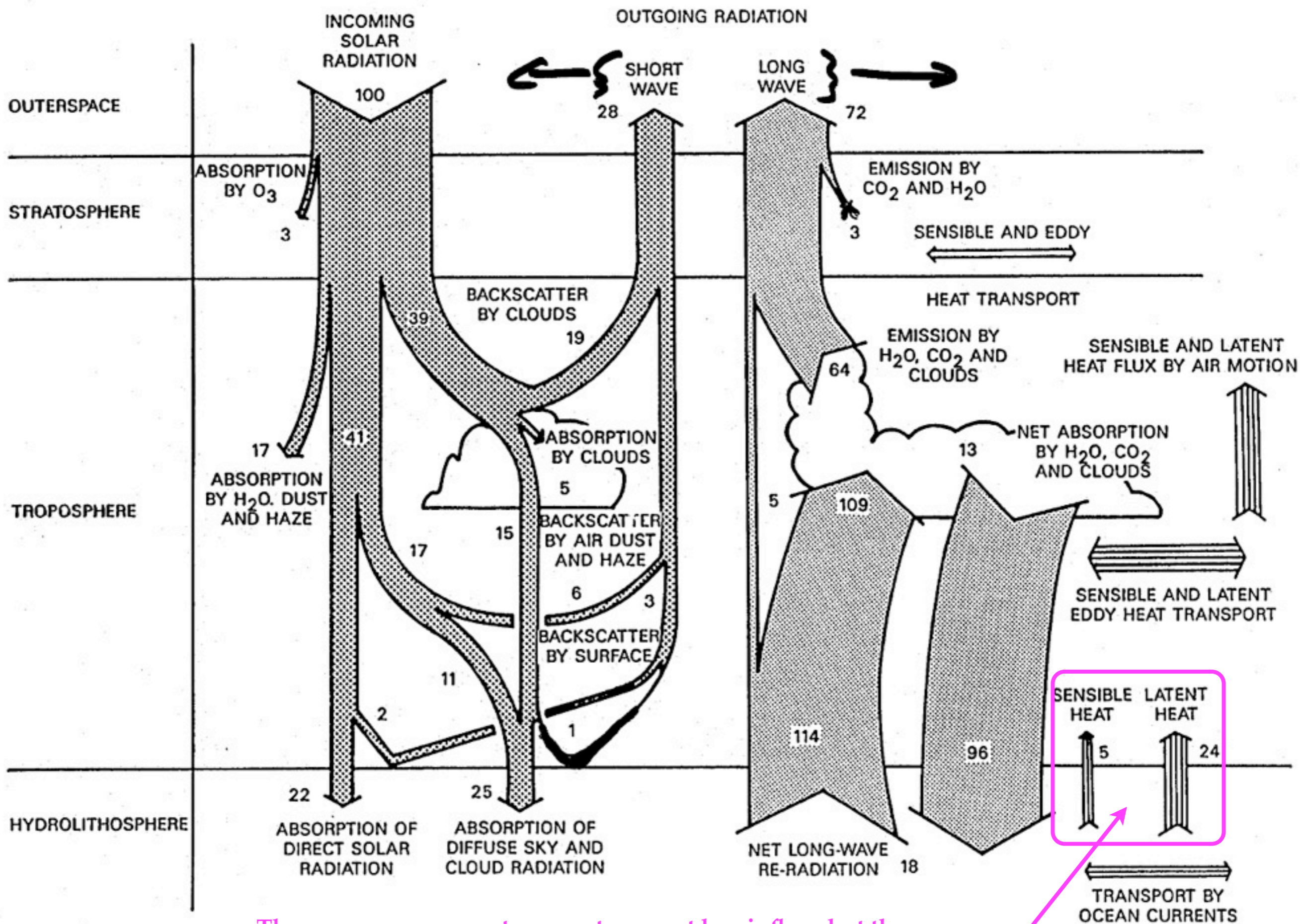

Figure 12. Schematic diagram of the disposition of absorbed solar energy in the Earth system.





These arrows represent energy transport by air flow, but they are very important to the energy balance between the surface and the atmosphere.



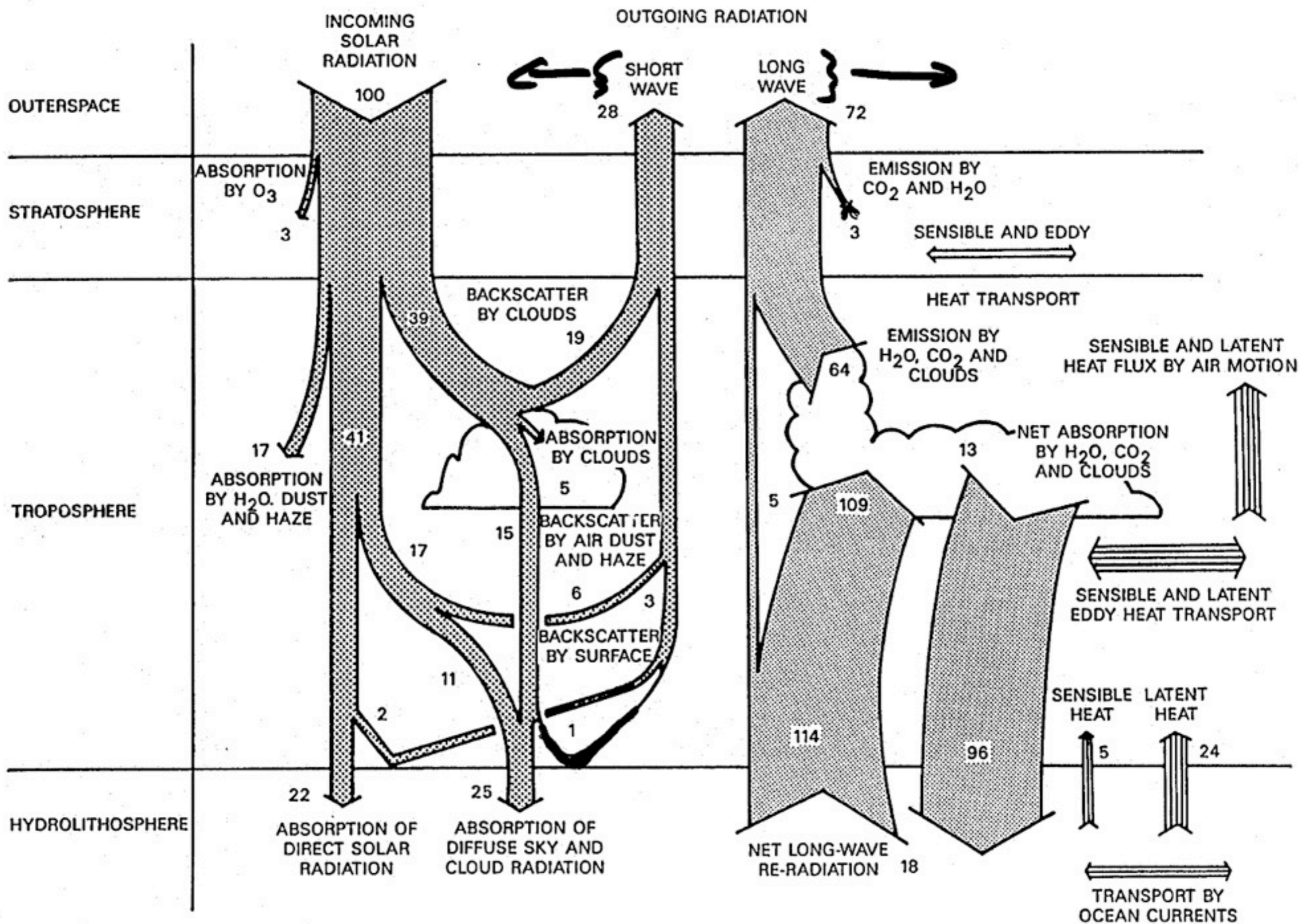

Figure 12. Schematic diagram of the disposition of absorbed solar energy in the Earth system.



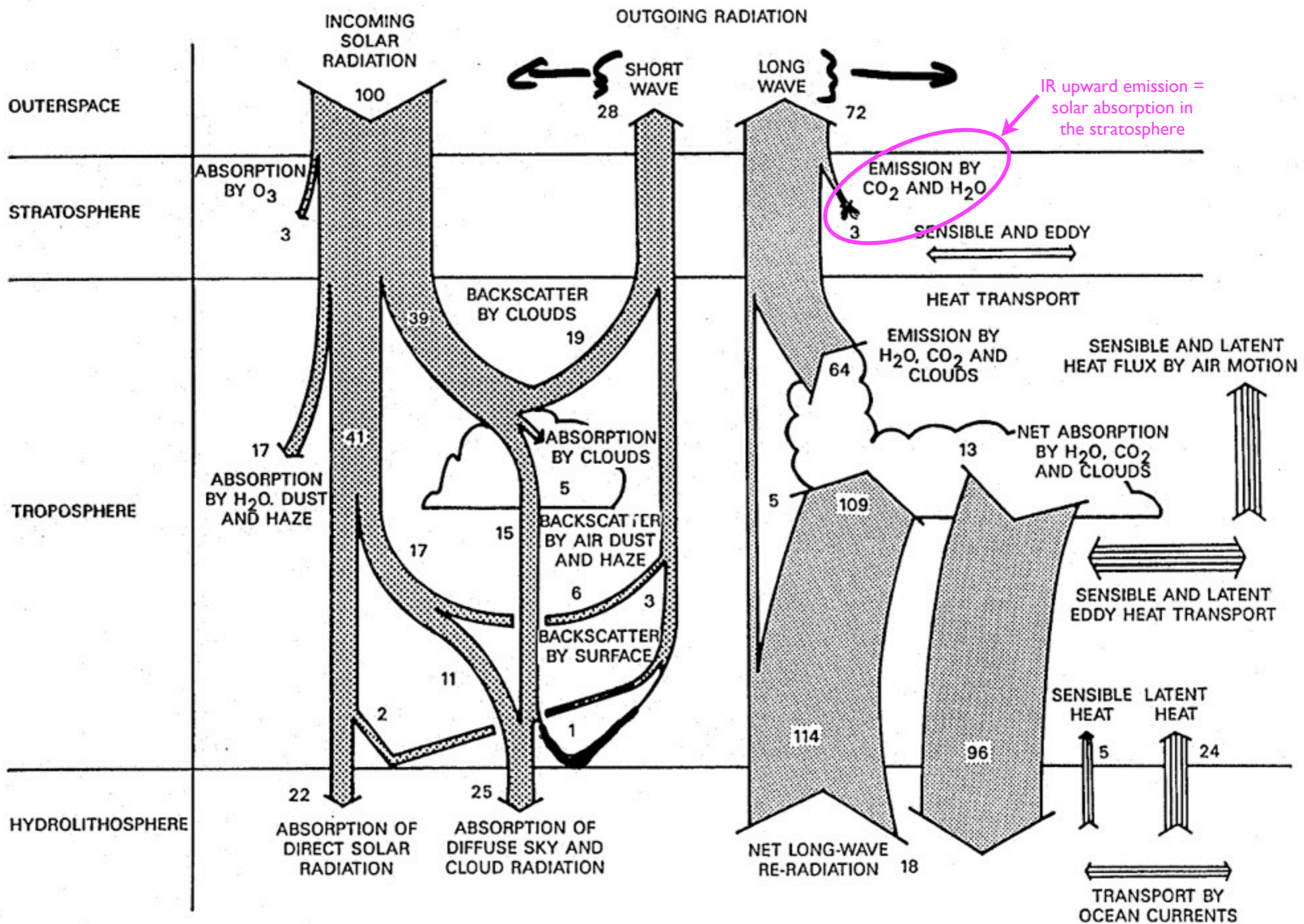
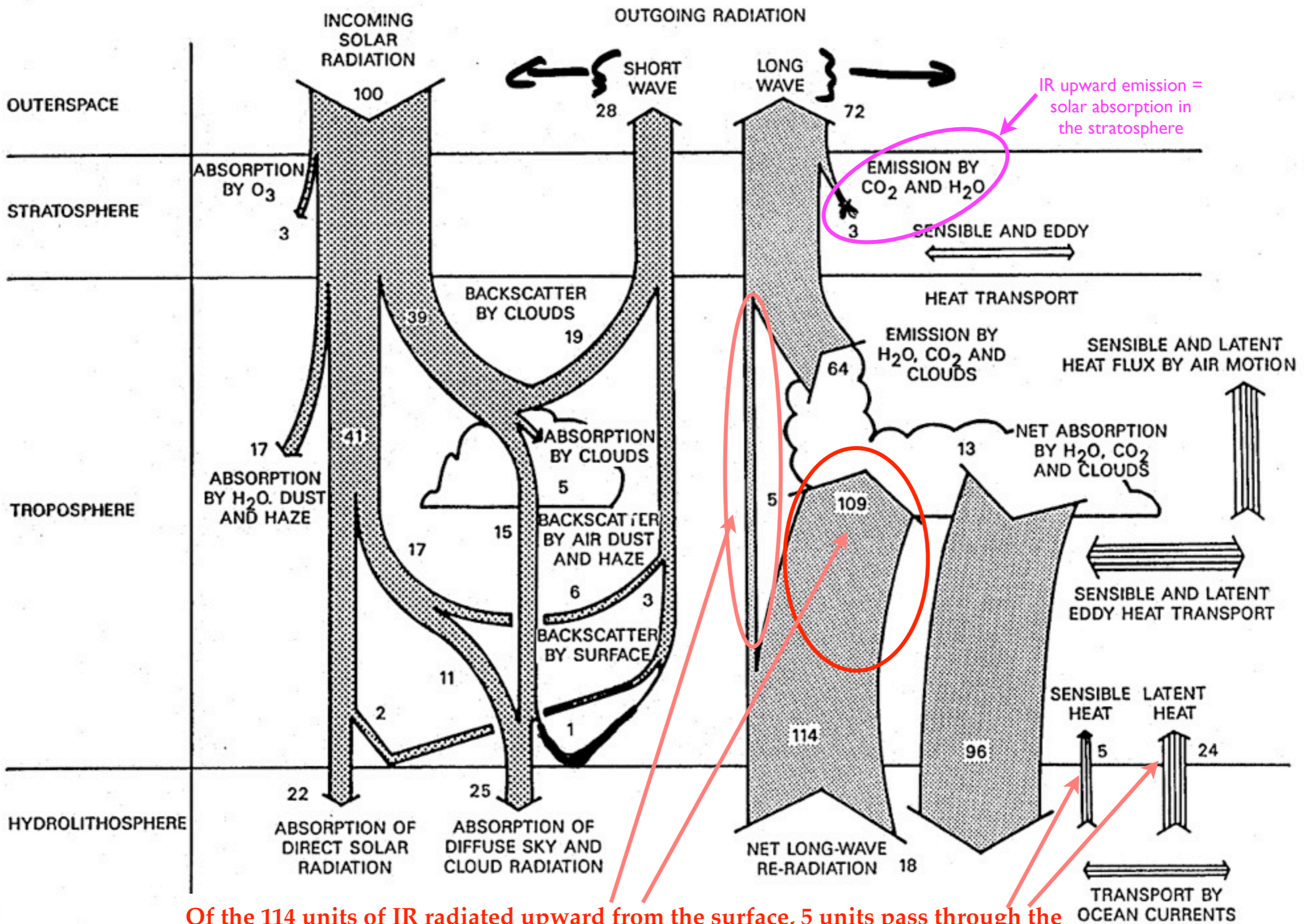

Figure 12. Schematic diagram of the disposition of absorbed solar energy in the Earth system.





Of the 114 units of IR radiated upward from the surface, 5 units pass through the atmosphere to space while 109 units are absorbed by the atmosphere. Sensible heat and latent heat add 29 units of upward energy into the atmosphere.



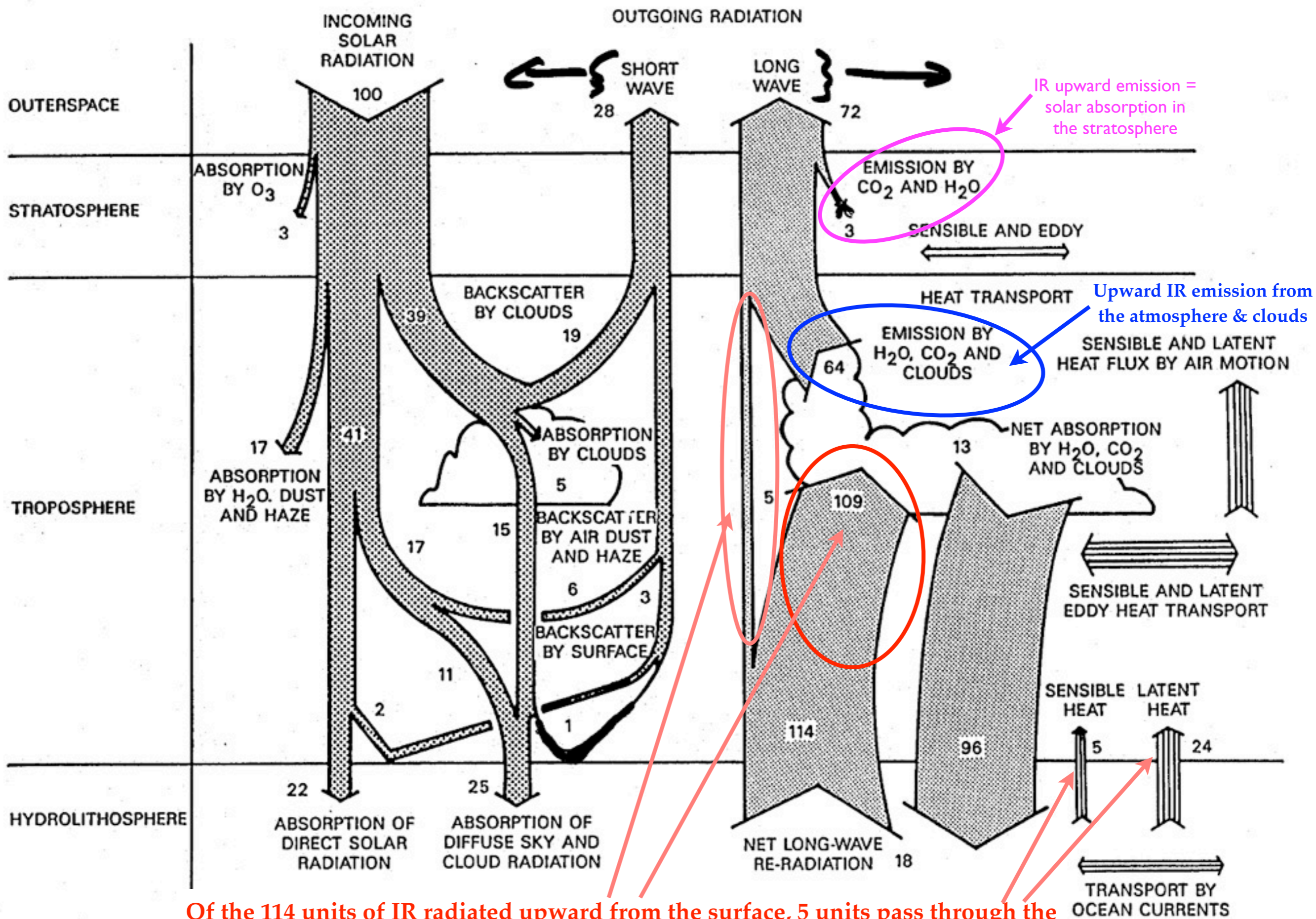

Of the 114 units of IR radiated upward from the surface, 5 units pass through the atmosphere to space while 109 units are absorbed by the atmosphere. Sensible heat and latent heat add 29 units of upward energy into the atmosphere.



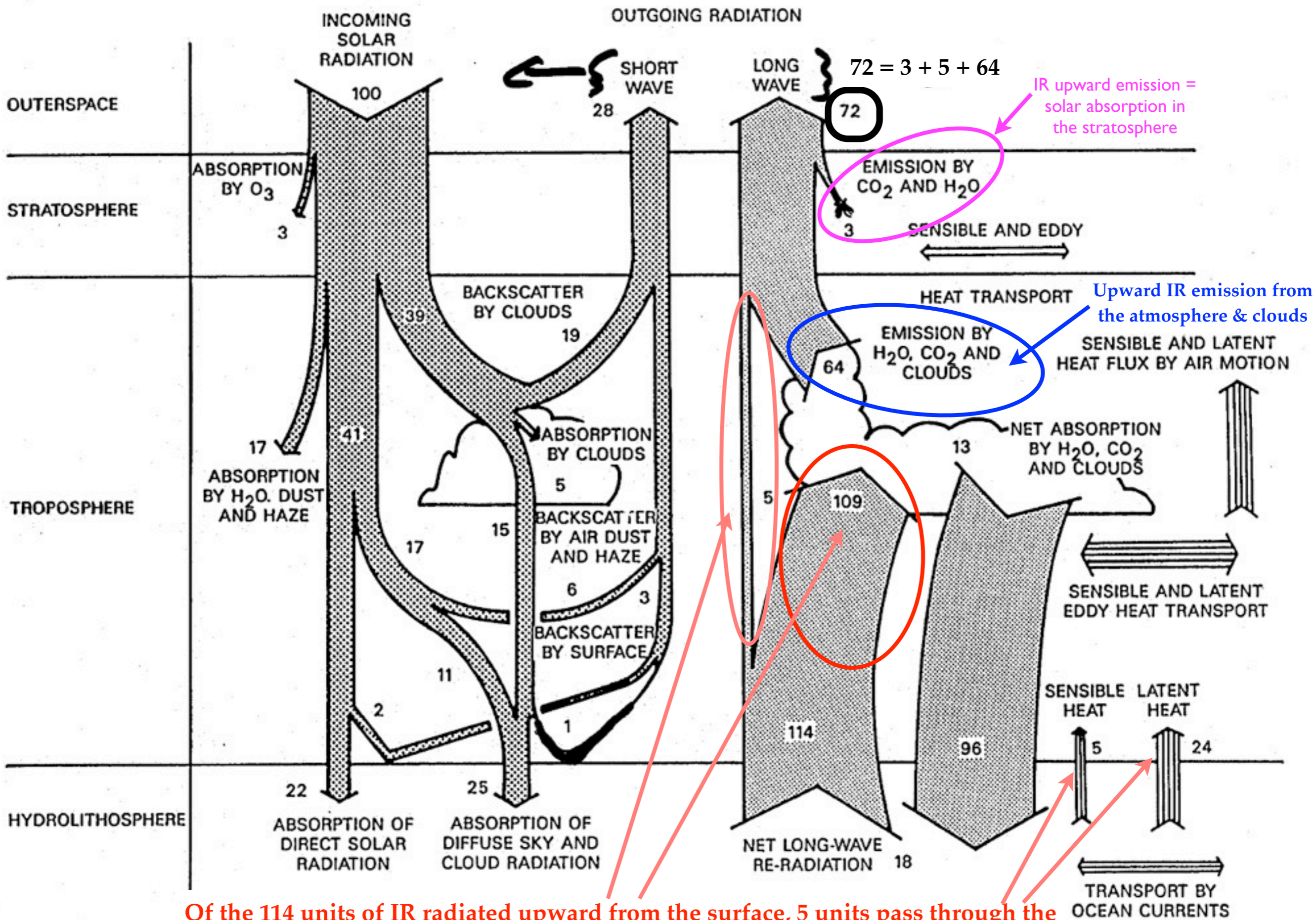

**Of the 114 units of IR radiated upward from the surface, 5 units pass through the atmosphere to space while 109 units are absorbed by the atmosphere. Sensible heat and latent heat add 29 units of upward energy into the atmosphere.**



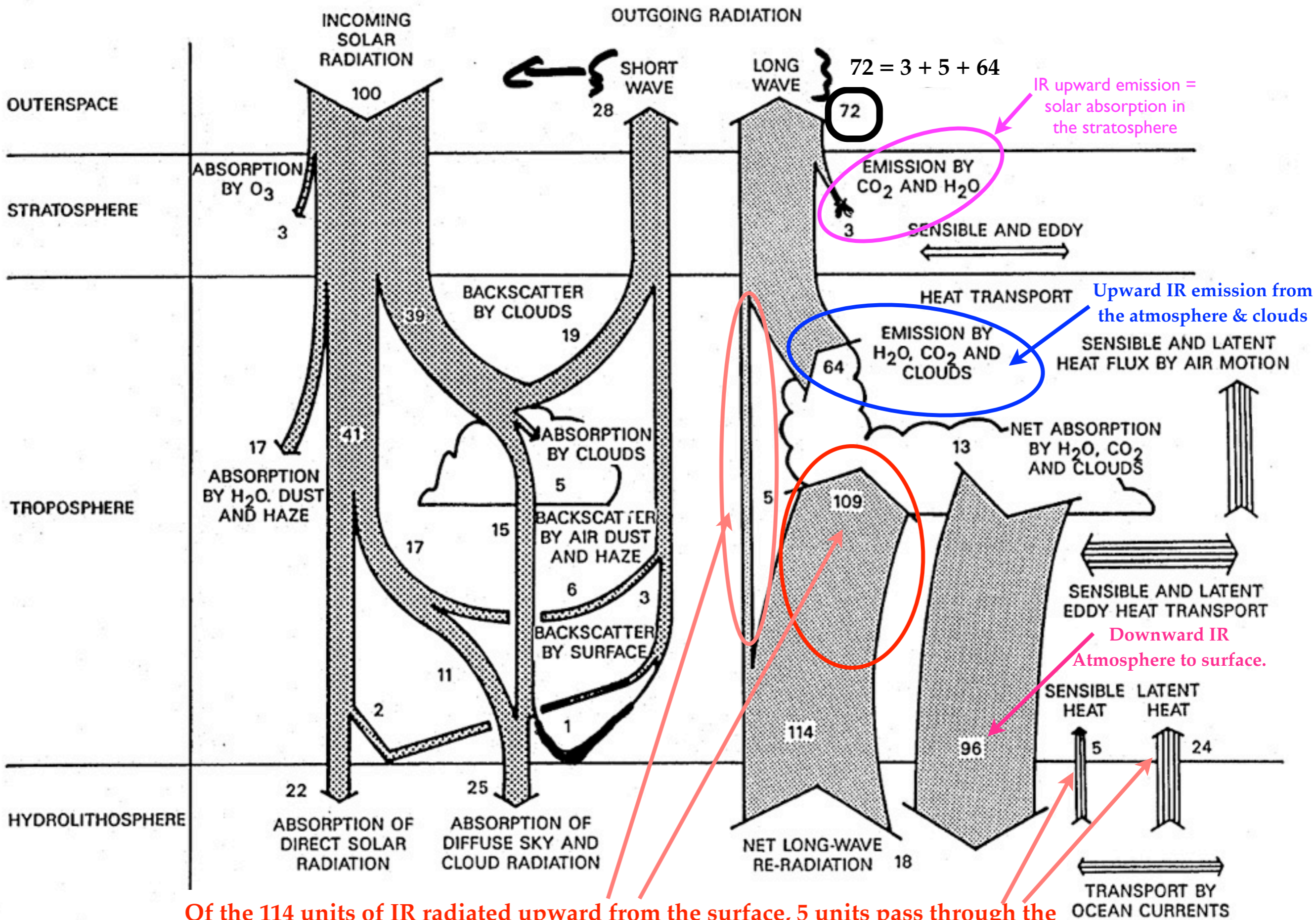

Of the 114 units of IR radiated upward from the surface, 5 units pass through the atmosphere to space while 109 units are absorbed by the atmosphere. Sensible heat and latent heat add 29 units of upward energy into the atmosphere.

**When the Earth is viewed from space in infrared radiation,  
we mostly see air and clouds (67 units),  
and a small surface contribution (5 units).**

---

## **Note the following:**

**The downward IR radiation from the atmosphere (96 units) is larger than the downward solar radiation (47 units) by a factor more than 2.**

---

**More solar radiation arrives at the surface after atmospheric scattering processes (25 units) than by direct sunlight (22).**

---

**Energy balance at the surface is only achieved when sensible and latent heats are included.**

$$\text{Solar in } 22 + 25 = 47$$

$$\text{IR in } 96$$

$$\text{IR out } -114; \text{ Sensible and Latent out } -29; \text{ Total out } = -143$$

$$\text{Net } = -47$$

When the Earth is viewed from space in infrared radiation, we mostly see air and clouds (67 units), and a small surface contribution (5 units).

---

**Note the following:**

The downward IR radiation from the atmosphere (96 units) is larger than the downward solar radiation (47 units) by a factor more than 2.

---

More solar radiation arrives at the surface after atmospheric scattering processes (25 units) than by direct sunlight (22).

---

Energy balance at the surface is only achieved when sensible and latent heats are included.

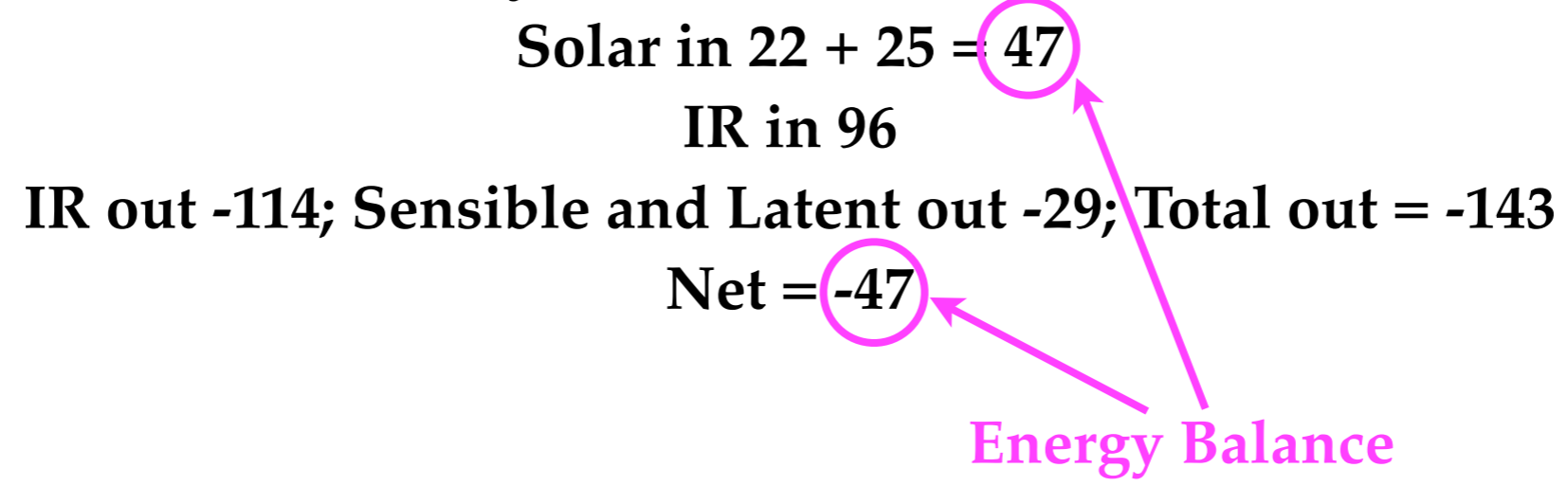



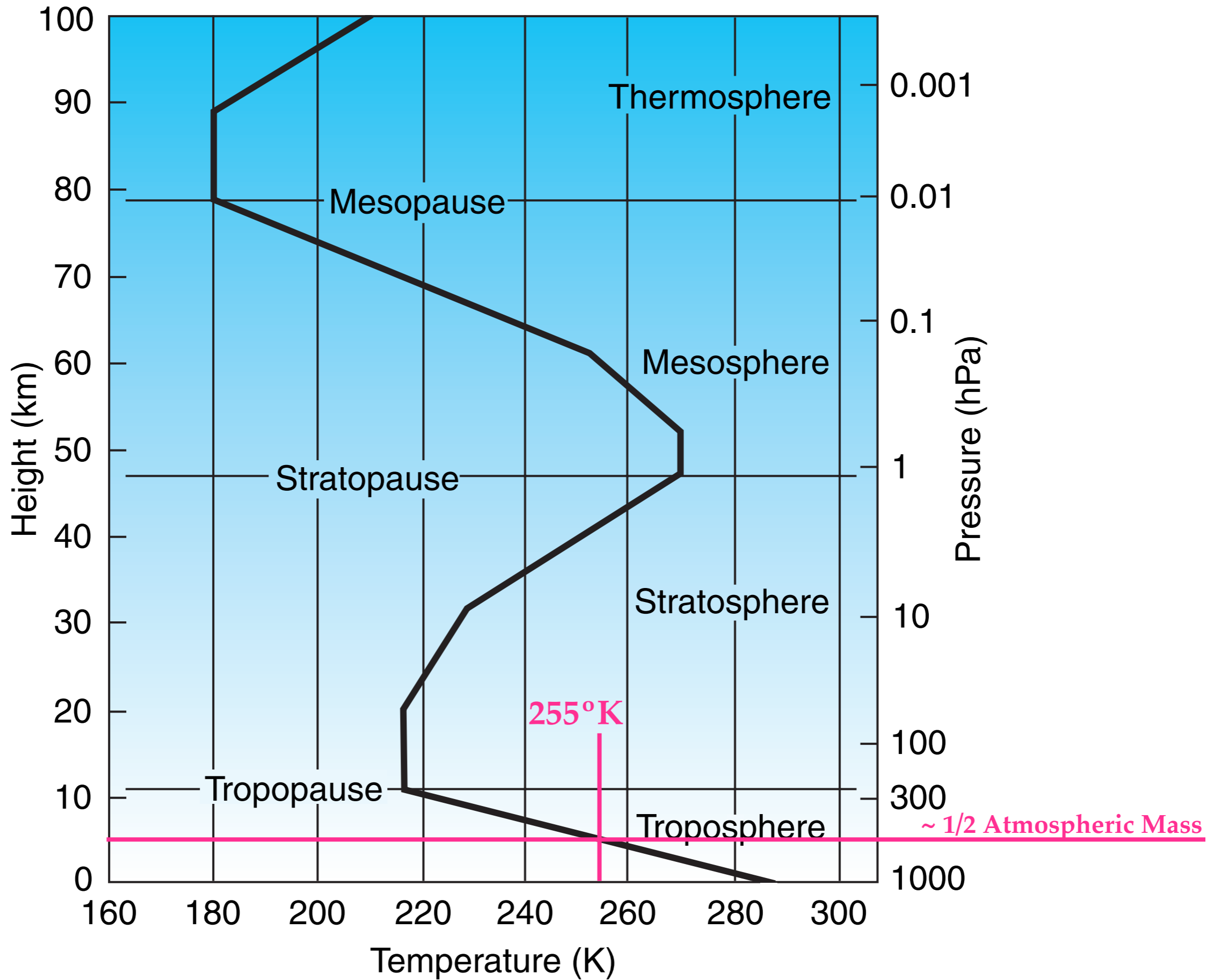

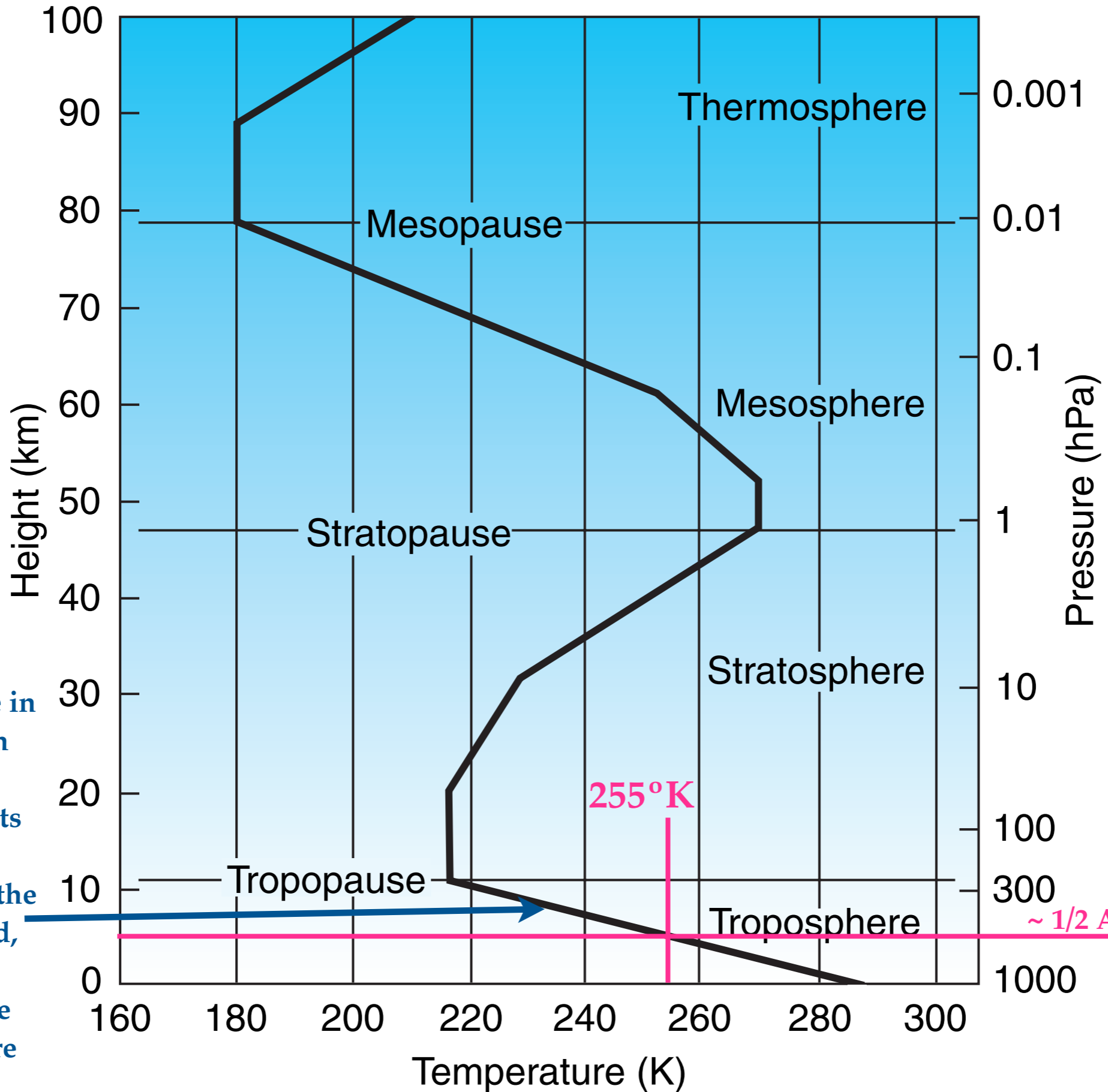

The rapid decrease in temperature with altitude in the troposphere results primarily from convection. When the surface is warmed, convection is enhanced and the upper troposphere gets colder.

~ 1/2 Atmospheric Mass

## Radiative forcing of climate between 1750 and 2005

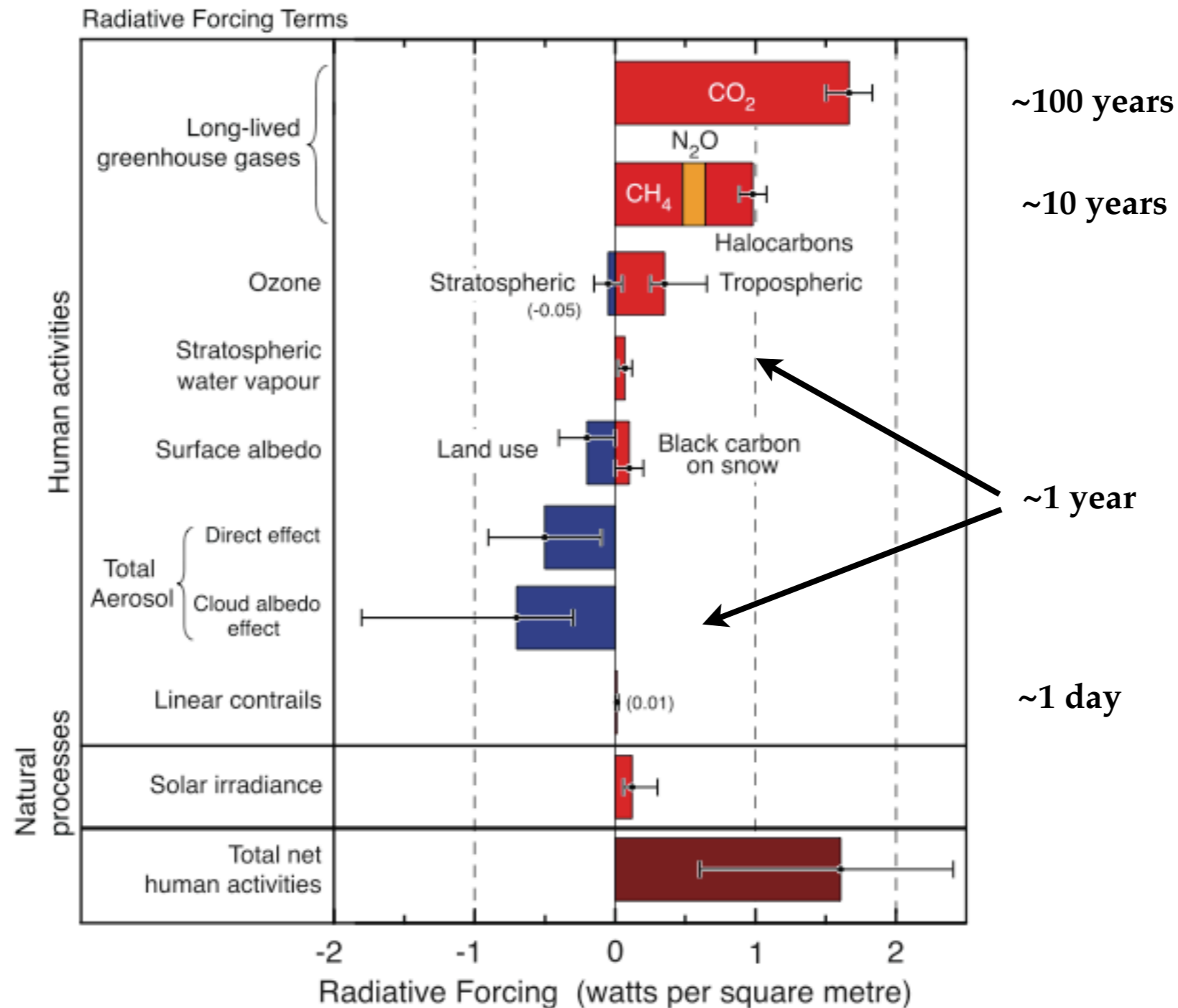

**FAQ 2.1, Figure 2.** Summary of the principal components of the radiative forcing of climate change. All these radiative forcings result from one or more factors that affect climate and are associated with human activities or natural processes as discussed in the text. The values represent the forcings in 2005 relative to the start of the industrial era (about 1750). Human activities cause significant changes in long-lived gases, ozone, water vapour, surface albedo, aerosols and contrails. The only increase in natural forcing of any significance between 1750 and 2005 occurred in solar irradiance. Positive forcings lead to warming of climate and negative forcings lead to a cooling. The thin black line attached to each coloured bar represents the range of uncertainty for the respective value. (Figure adapted from Figure 2.20 of this report.)



## Radiative forcing of climate between 1750 and 2005

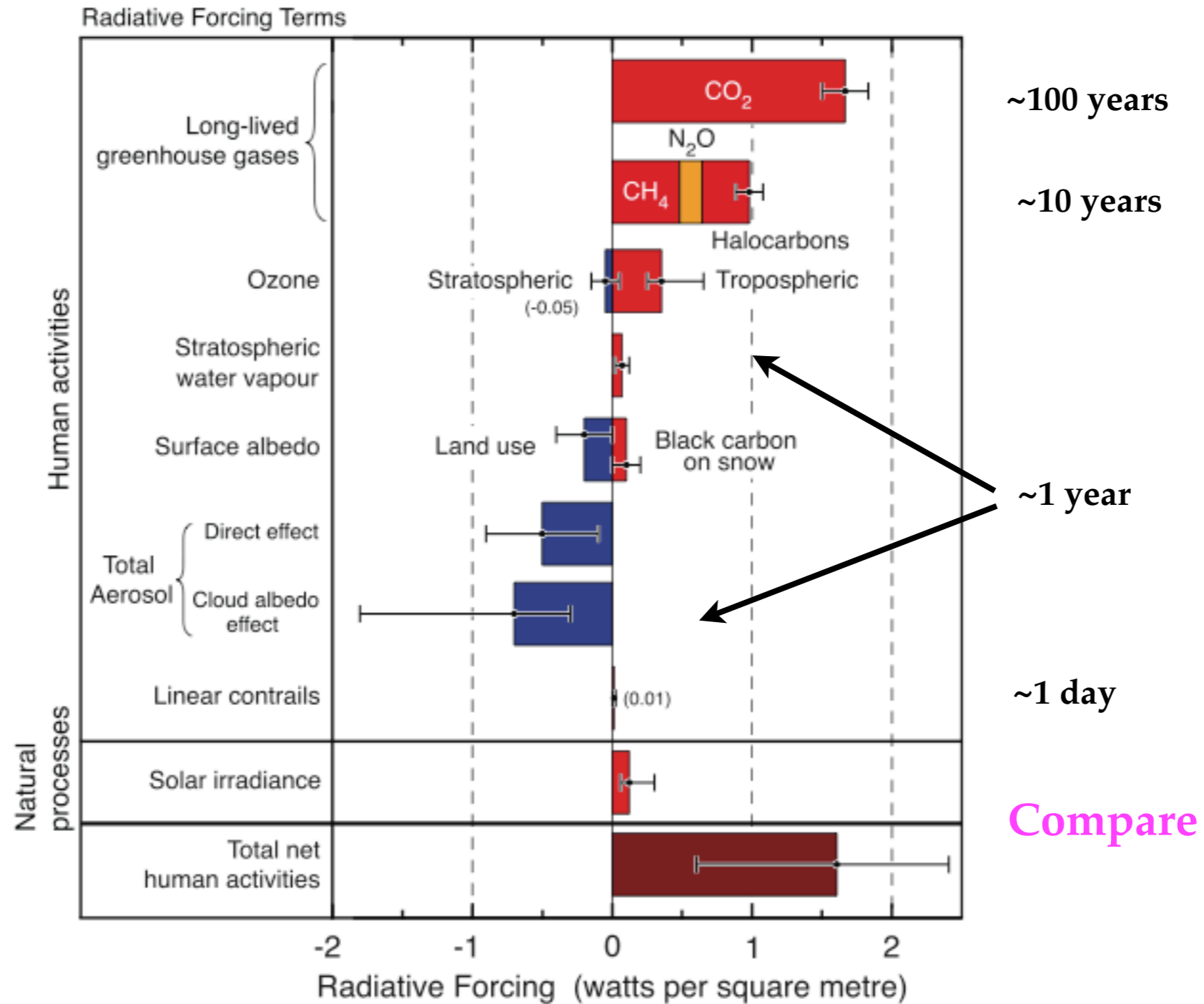

**FAQ 2.1, Figure 2.** Summary of the principal components of the radiative forcing of climate change. All these radiative forcings result from one or more factors that affect climate and are associated with human activities or natural processes as discussed in the text. The values represent the forcings in 2005 relative to the start of the industrial era (about 1750). Human activities cause significant changes in long-lived gases, ozone, water vapour, surface albedo, aerosols and contrails. The only increase in natural forcing of any significance between 1750 and 2005 occurred in solar irradiance. Positive forcings lead to warming of climate and negative forcings lead to a cooling. The thin black line attached to each coloured bar represents the range of uncertainty for the respective value. (Figure adapted from Figure 2.20 of this report.)

## Radiative forcing of climate between 1750 and 2005

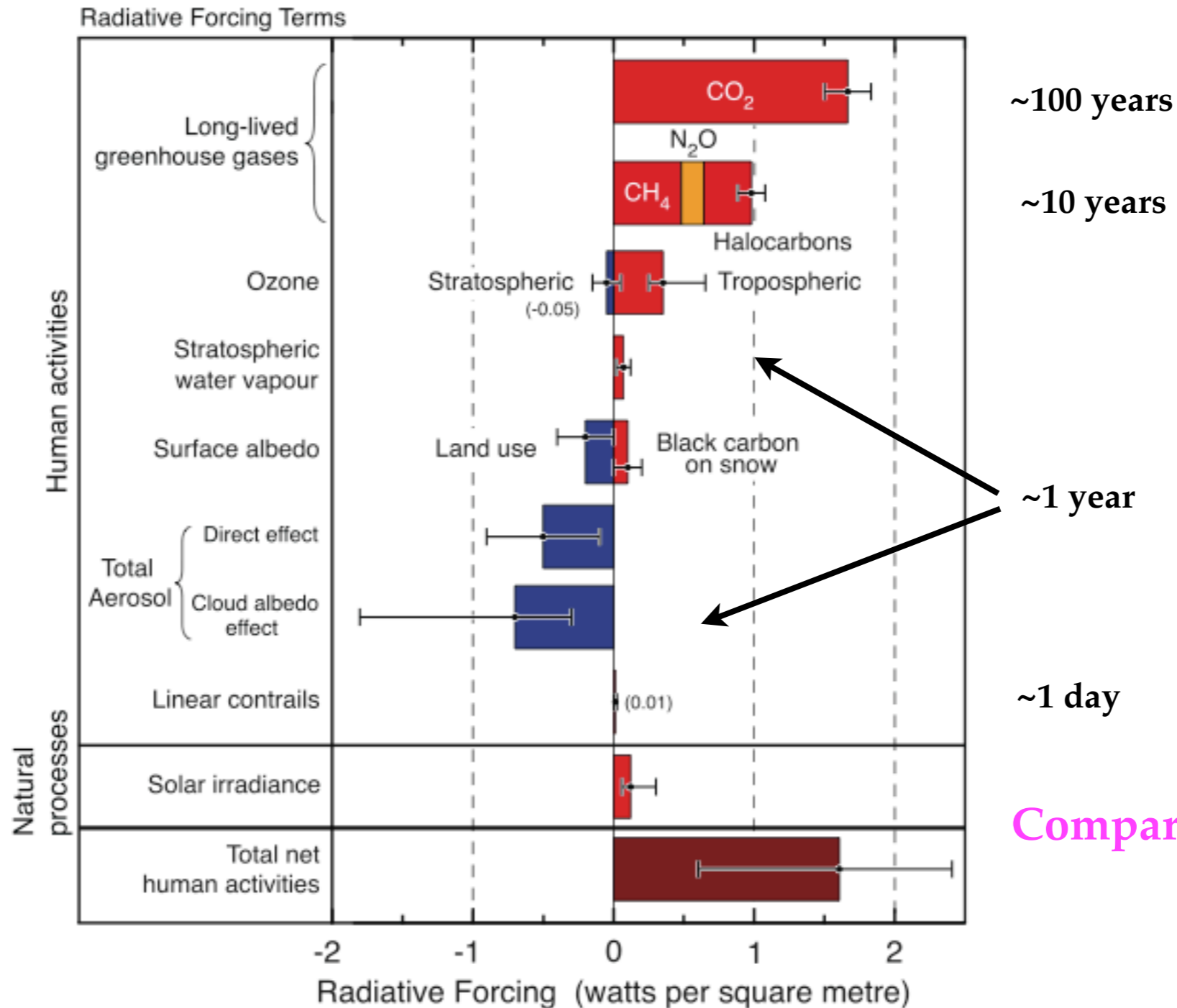

Not shown is water vapor, a strong greenhouse gas; the lifetime for water vapor in the atmosphere is 7-10 days.

Although a natural atmospheric component evaporation increases with surface warming; this is a positive feedback process that responds to carbon dioxide increases.

Compare

**FAQ 2.1, Figure 2.** Summary of the principal components of the radiative forcing of climate change. All these radiative forcings result from one or more factors that affect climate and are associated with human activities or natural processes as discussed in the text. The values represent the forcings in 2005 relative to the start of the industrial era (about 1750). Human activities cause significant changes in long-lived gases, ozone, water vapour, surface albedo, aerosols and contrails. The only increase in natural forcing of any significance between 1750 and 2005 occurred in solar irradiance. Positive forcings lead to warming of climate and negative forcings lead to a cooling. The thin black line attached to each coloured bar represents the range of uncertainty for the respective value. (Figure adapted from Figure 2.20 of this report.)

### Frequently Asked Question 7.1

## **Are the Increases in Atmospheric Carbon Dioxide and Other Greenhouse Gases During the Industrial Era Caused by Human Activities?**

*Yes, the increases in atmospheric carbon dioxide (CO<sub>2</sub>) and other greenhouse gases during the industrial era are caused by human activities. In fact, the observed increase in atmospheric CO<sub>2</sub> concentrations does not reveal the full extent of human emissions in that it accounts for only 55% of the CO<sub>2</sub> released by human activity since 1959. The rest has been taken up by plants on land and by the oceans. In all cases, atmospheric concentrations of greenhouse gases, and their increases, are determined by the balance between sources (emissions of the gas from human activities and natural systems) and sinks (the removal of the gas from the atmosphere by conversion to a different chemical compound). Fossil fuel combustion (plus a smaller contribution from cement manufacture) is responsible for more than 75% of human-caused CO<sub>2</sub> emissions. Land use change (primarily deforestation) is responsible for the remainder. For methane, another important greenhouse gas, emissions generated by human activities exceeded natural emissions over the last 25 years. For nitrous oxide, emissions generated by human activities are equal to natural emissions to the atmosphere.*



### Frequently Asked Question 7.1

## **Are the Increases in Atmospheric Carbon Dioxide and Other Greenhouse Gases During the Industrial Era Caused by Human Activities?**

*Yes, the increases in atmospheric carbon dioxide (CO<sub>2</sub>) and other greenhouse gases during the industrial era are caused by human activities. In fact, the observed increase in atmospheric CO<sub>2</sub> concentrations does not reveal the full extent of human emissions in that it accounts for only 55% of the CO<sub>2</sub> released by human activity since 1959. The rest has been taken up by plants on land and by the oceans. In all cases, atmospheric concentrations of greenhouse gases, and their increases, are determined by the balance between sources (emissions of the gas from human activities and natural systems) and sinks (the removal of the gas from the atmosphere by conversion to a different chemical compound). Fossil fuel combustion (plus a smaller contribution from cement manufacture) is responsible for more than 75% of human-caused CO<sub>2</sub> emissions. Land use change (primarily deforestation) is responsible for the remainder. For methane, another important greenhouse gas, emissions generated by human activities exceeded natural emissions over the last 25 years. For nitrous oxide, emissions generated by human activities are equal to natural emissions to the atmosphere.*

### Frequently Asked Question 7.1

## **Are the Increases in Atmospheric Carbon Dioxide and Other Greenhouse Gases During the Industrial Era Caused by Human Activities?**

*Yes, the increases in atmospheric carbon dioxide (CO<sub>2</sub>) and other greenhouse gases during the industrial era are caused by human activities. In fact, the observed increase in atmospheric CO<sub>2</sub> concentrations does not reveal the full extent of human emissions in that it accounts for only 55% of the CO<sub>2</sub> released by human activity since 1959. The rest has been taken up by plants on land and by the oceans. In all cases, atmospheric concentrations of greenhouse gases, and their increases, are determined by the balance between sources (emissions of the gas from human activities and natural systems) and sinks (the removal of the gas from the atmosphere by conversion to a different chemical compound). Fossil fuel combustion (plus a smaller contribution from cement manufacture) is responsible for more than 75% of human-caused CO<sub>2</sub> emissions. Land use change (primarily deforestation) is responsible for the remainder. For methane, another important greenhouse gas, emissions generated by human activities exceeded natural emissions over the last 25 years. For nitrous oxide, emissions generated by human activities are equal to natural emissions to the atmosphere.*



## Carbon dioxide is the primary villain!

Two important greenhouse gasses for the past 440 years; CO<sub>2</sub> and CH<sub>4</sub>.

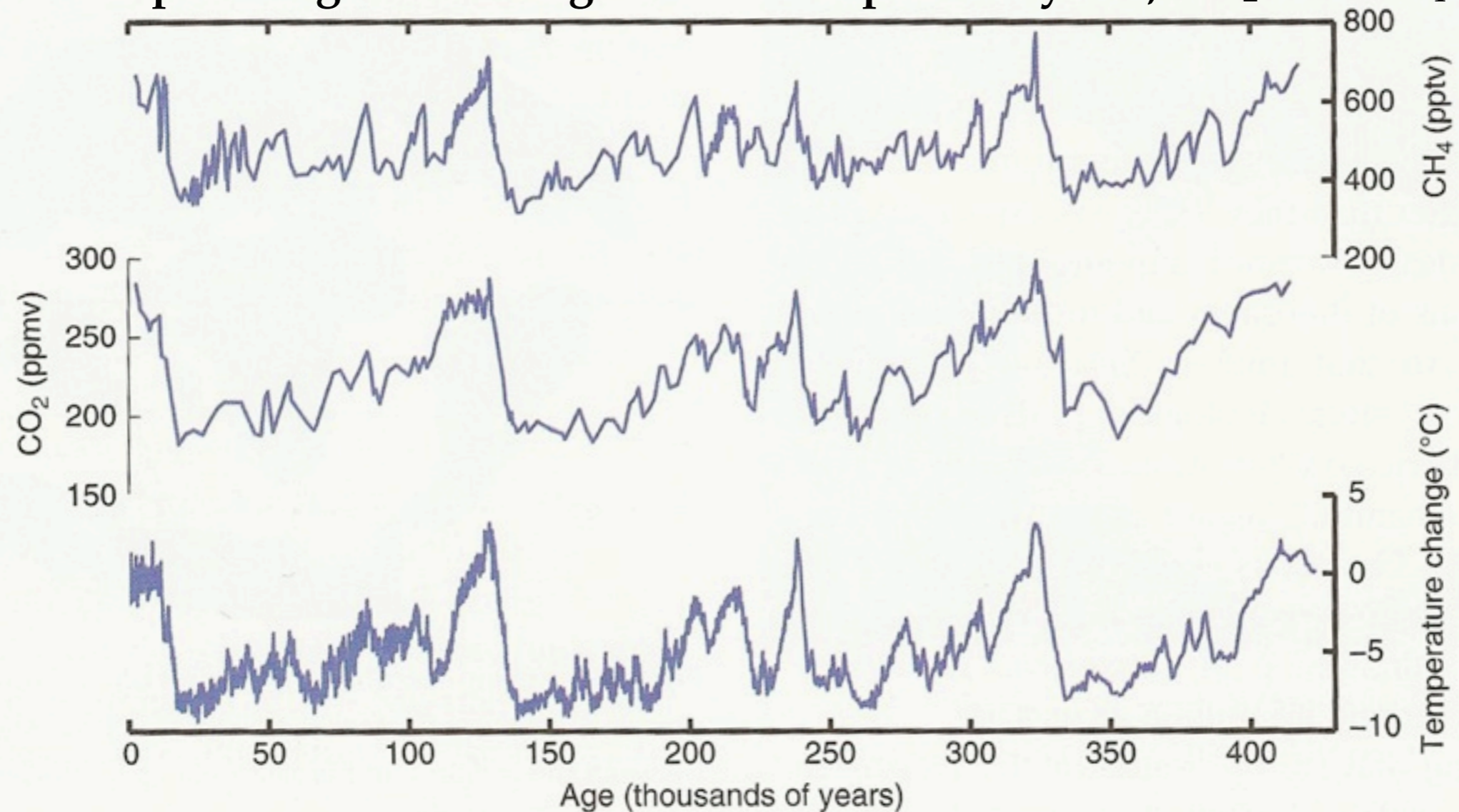

**Fig. 2.31** Comparison of methane, carbon dioxide, and estimated temperature (from oxygen and deuterium isotope ratios) from the Vostok ice core, Antarctica, over the last 440 thousand years. The location of Vostok is indicated by the red dot in Fig. 2.13. Note that the time axis runs from right to left. [Adapted from J. R. Petit et al., "Climate and atmospheric history of the past 420,000 years from the Vostok ice core, Antarctica." *Nature*, **399**, p. 431, 1999. Courtesy of Eric Steig.]



## What has changed?

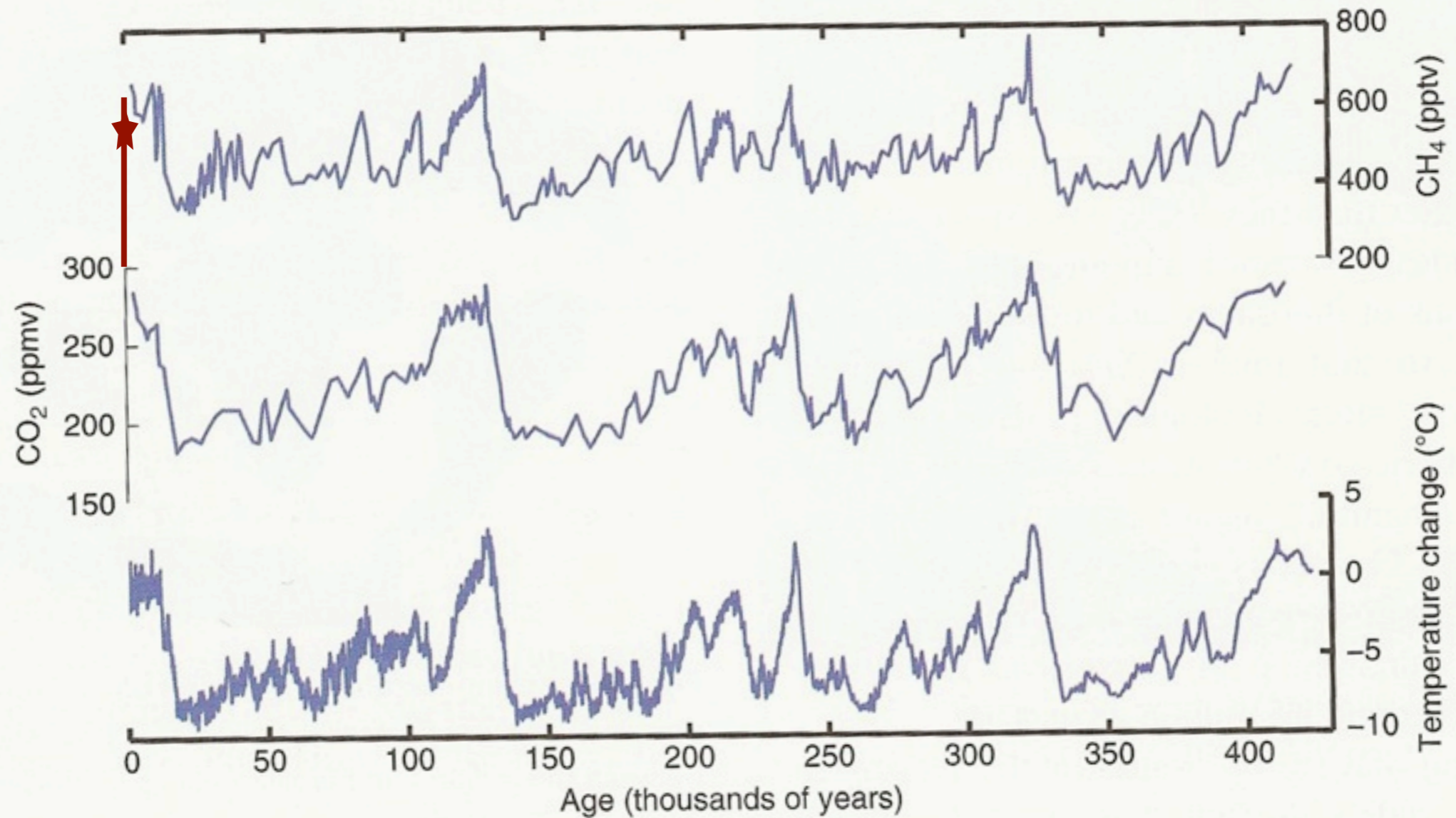
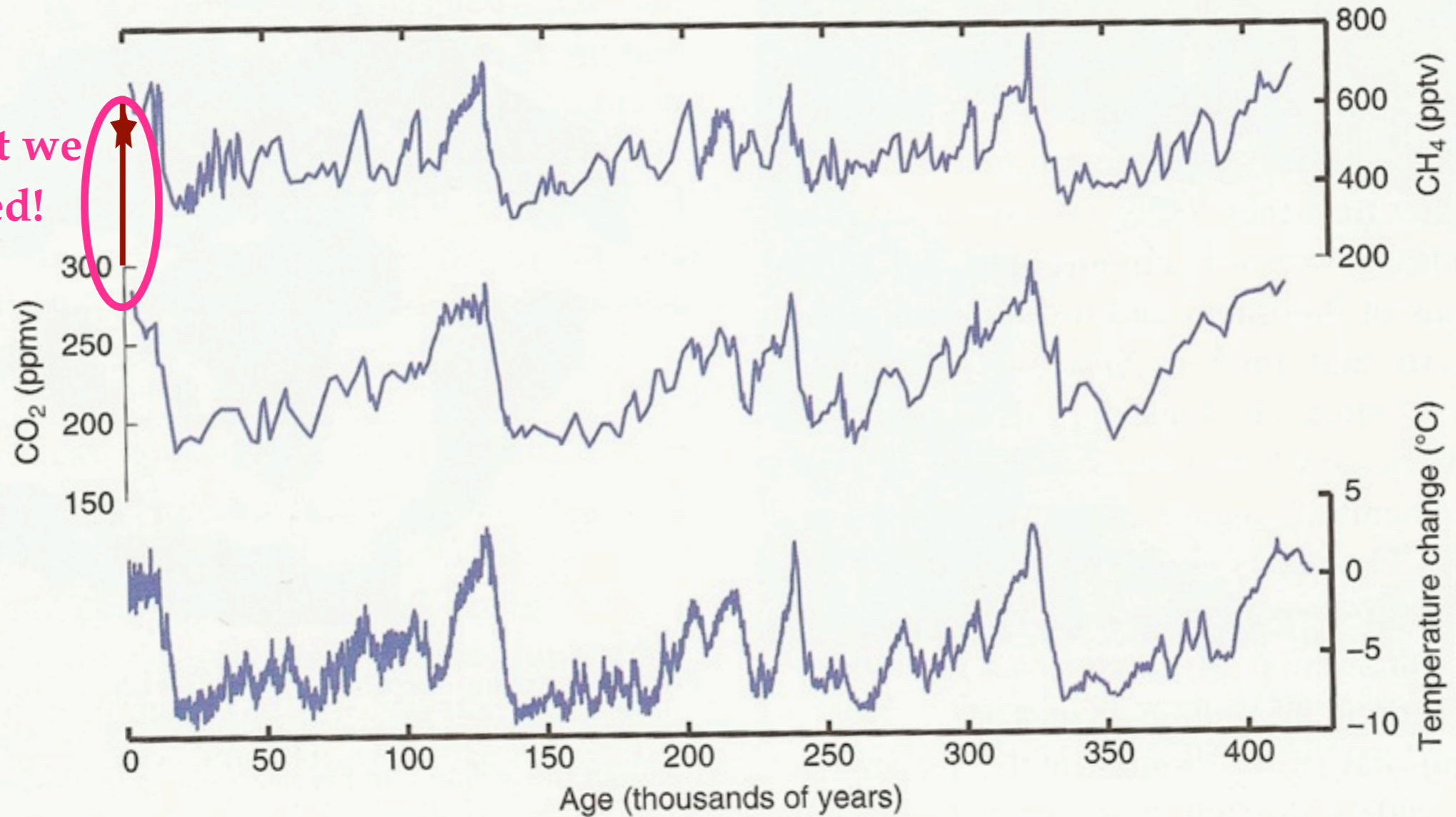

**Fig. 2.31** Comparison of methane, carbon dioxide, and estimated temperature (from oxygen and deuterium isotope ratios) from the Vostok ice core, Antarctica, over the last 440 thousand years. The location of Vostok is indicated by the red dot in Fig. 2.13. Note that the time axis runs from right to left. [Adapted from J. R. Petit et al., "Climate and atmospheric history of the past 420,000 years from the Vostok ice core, Antarctica." *Nature*, **399**, p. 431, 1999. Courtesy of Eric Steig.]



## What has changed?

This is what we  
have added!



**Fig. 2.31** Comparison of methane, carbon dioxide, and estimated temperature (from oxygen and deuterium isotope ratios) from the Vostok ice core, Antarctica, over the last 440 thousand years. The location of Vostok is indicated by the red dot in Fig. 2.13. Note that the time axis runs from right to left. [Adapted from J. R. Petit et al., "Climate and atmospheric history of the past 420,000 years from the Vostok ice core, Antarctica." *Nature*, **399**, p. 431, 1999. Courtesy of Eric Steig.]



## What has changed?

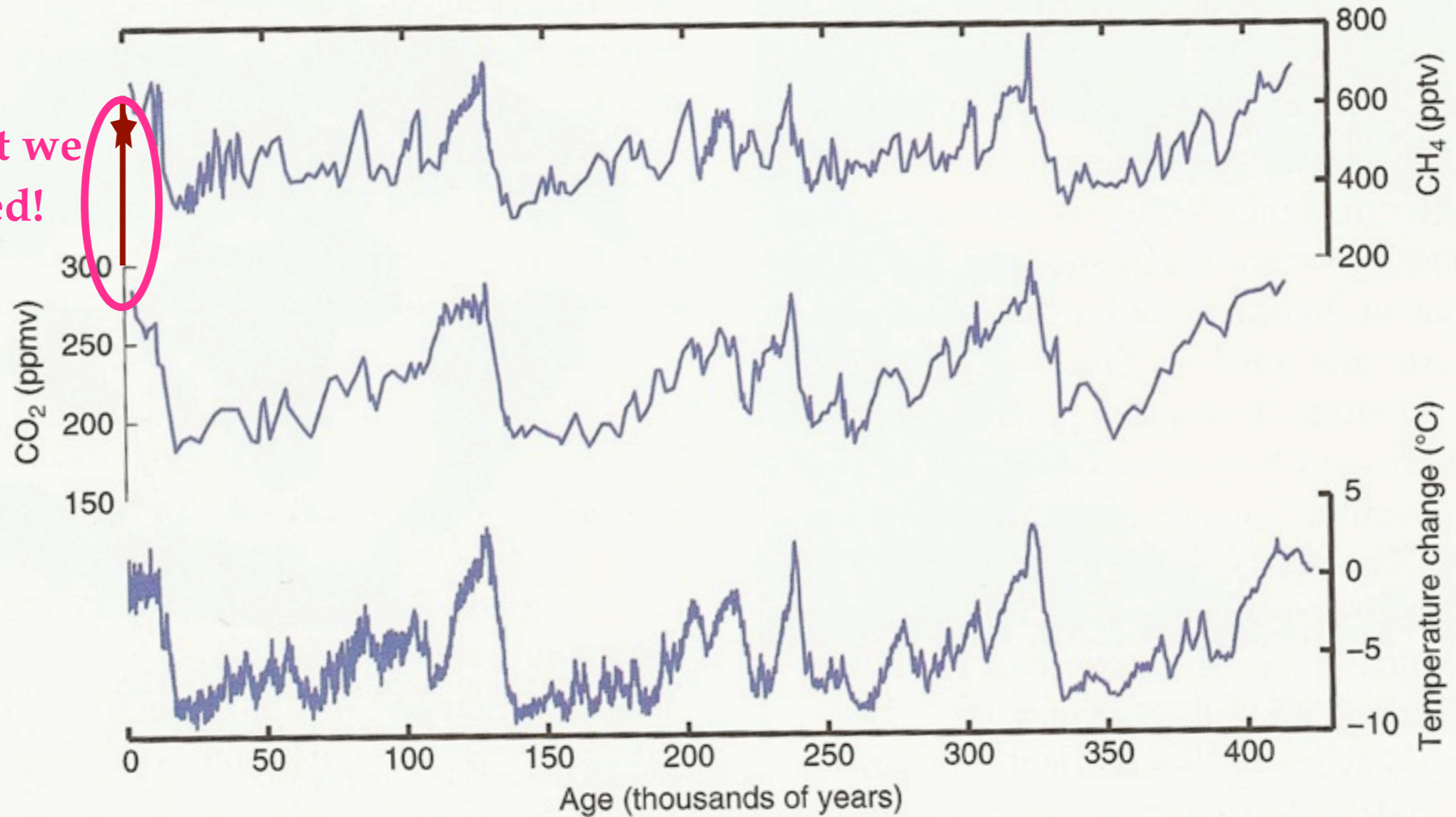

This is what we have added!

**Fig. 2.31** Comparison of methane, carbon dioxide, and estimated temperature (from oxygen and deuterium isotope ratios) from the Vostok ice core, Antarctica, over the last 440 thousand years. The location of Vostok is indicated by the red dot in Fig. 2.13. Note that the time axis runs from right to left. [Adapted from J. R. Petit et al., "Climate and atmospheric history of the past 420,000 years from the Vostok ice core, Antarctica." *Nature*, **399**, p. 431, 1999. Courtesy of Eric Steig.]

The Earth has not experienced this level of CO<sub>2</sub> in the last 440 thousand years; other ice cores go back 650 thousand and show the same result.



## What has changed?

This is what we  
have added!

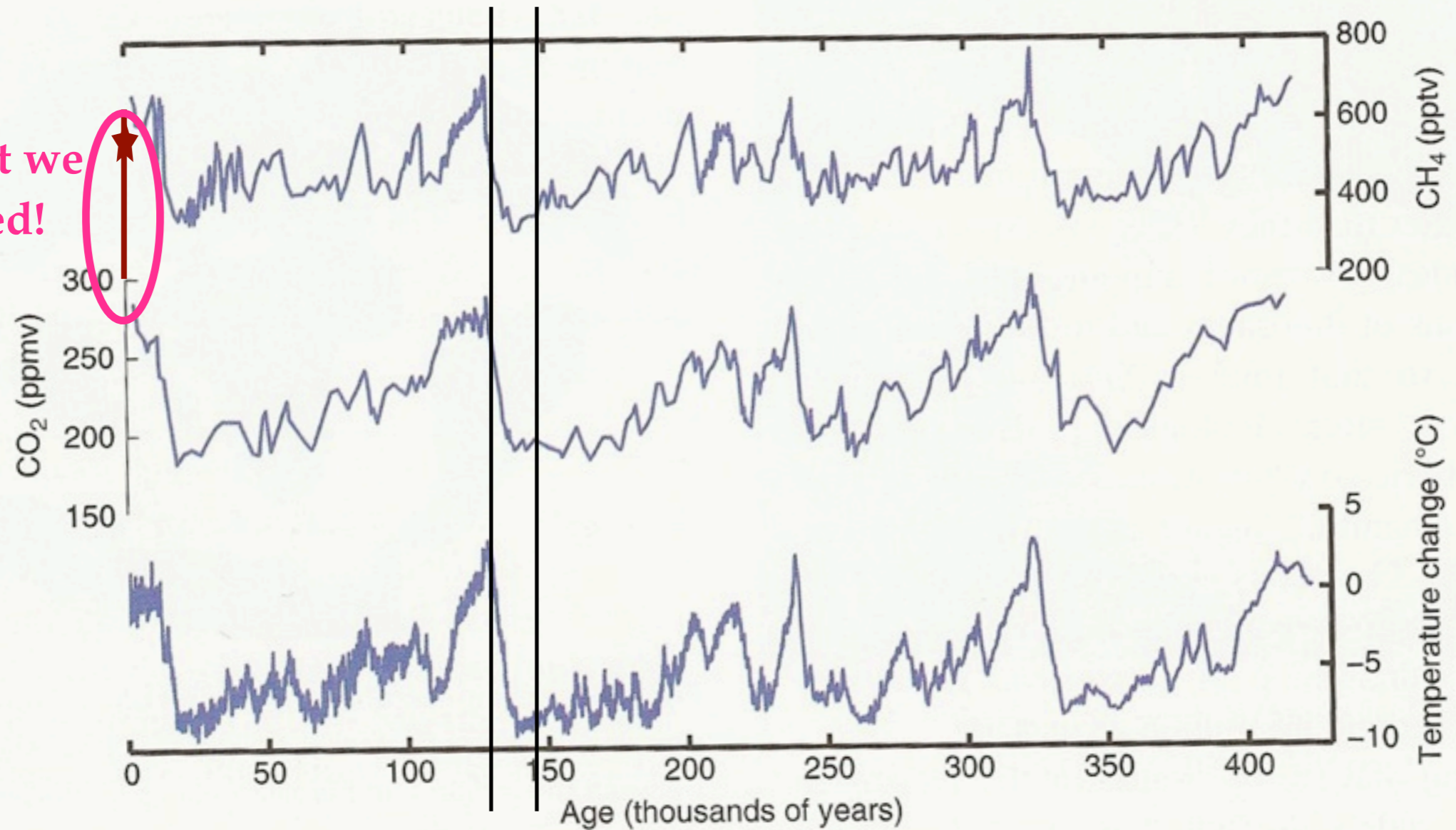
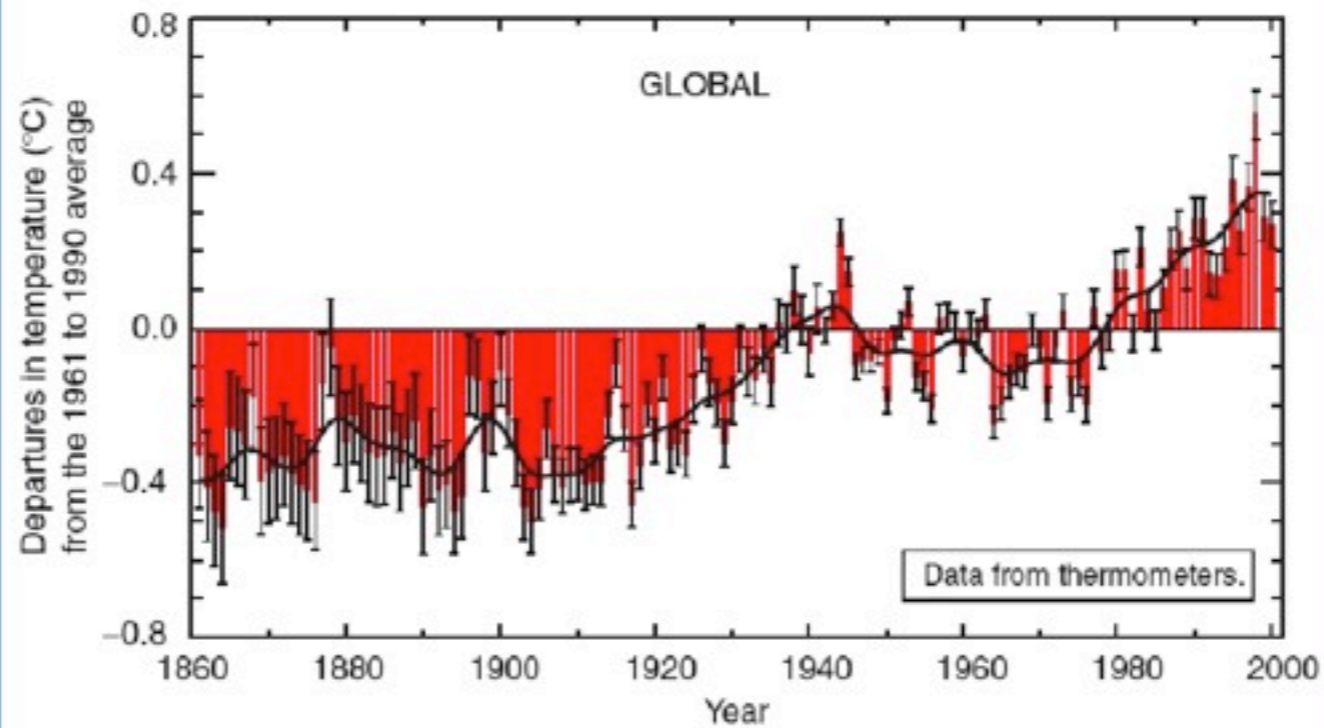

**Fig. 2.31** Comparison of methane, carbon dioxide, and estimated temperature (from oxygen and deuterium isotope ratios) from the Vostok ice core, Antarctica, over the last 440 thousand years. The location of Vostok is indicated by the red dot in Fig. 2.13. Note that the time axis runs from right to left. [Adapted from J. R. Petit et al., "Climate and atmospheric history of the past 420,000 years from the Vostok ice core, Antarctica." *Nature*, **399**, p. 431, 1999. Courtesy of Eric Steig.]

The Earth has not experienced this level of CO<sub>2</sub> in the last 440 thousand years; other ice cores go back 650 thousand and show the same result.

# Variations of the Earth's surface temperature for:

(a) the past 140 years



(b) the past 1,000 years

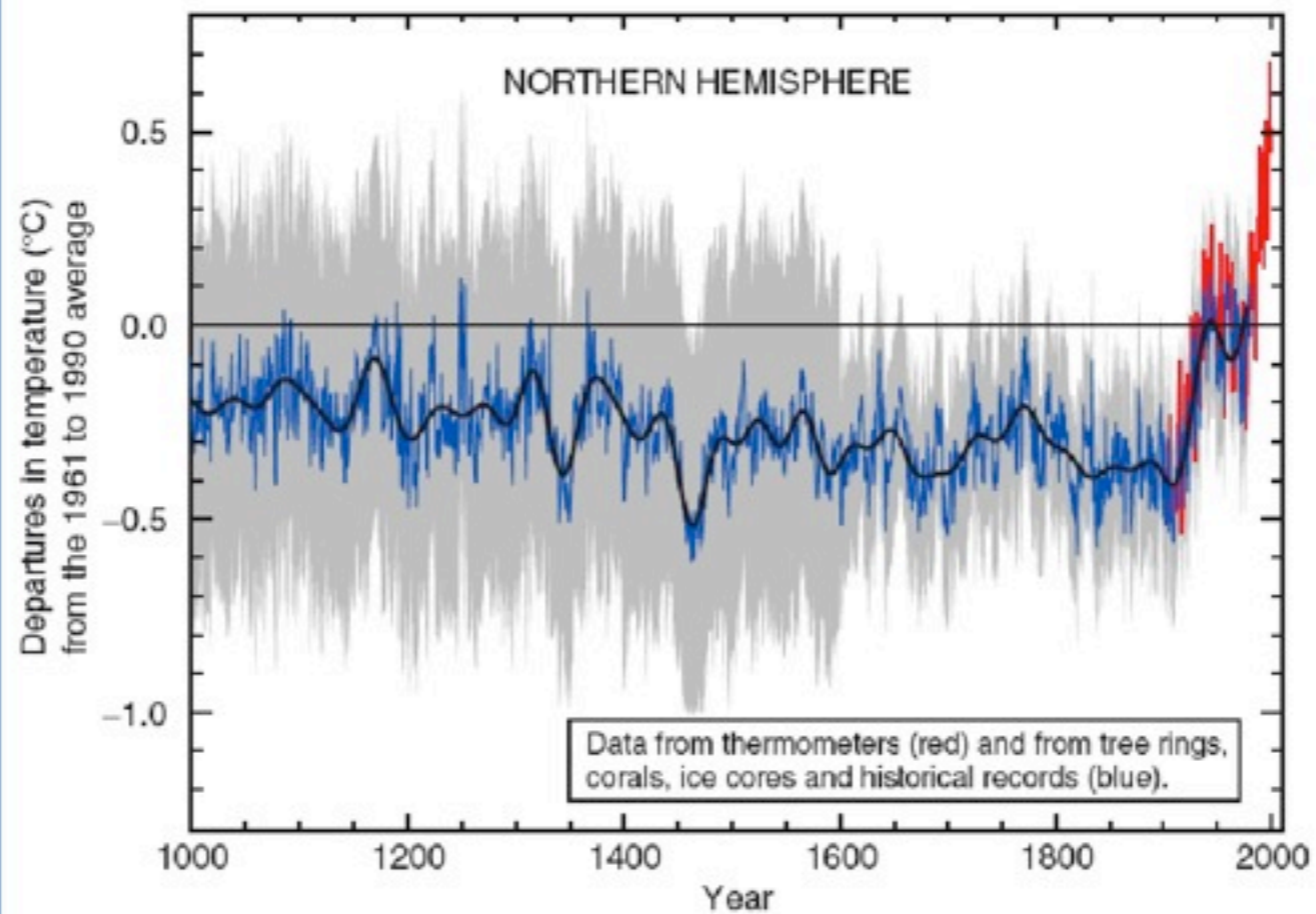



# Variations of the Earth's surface temperature for:

(a) the past 140 years

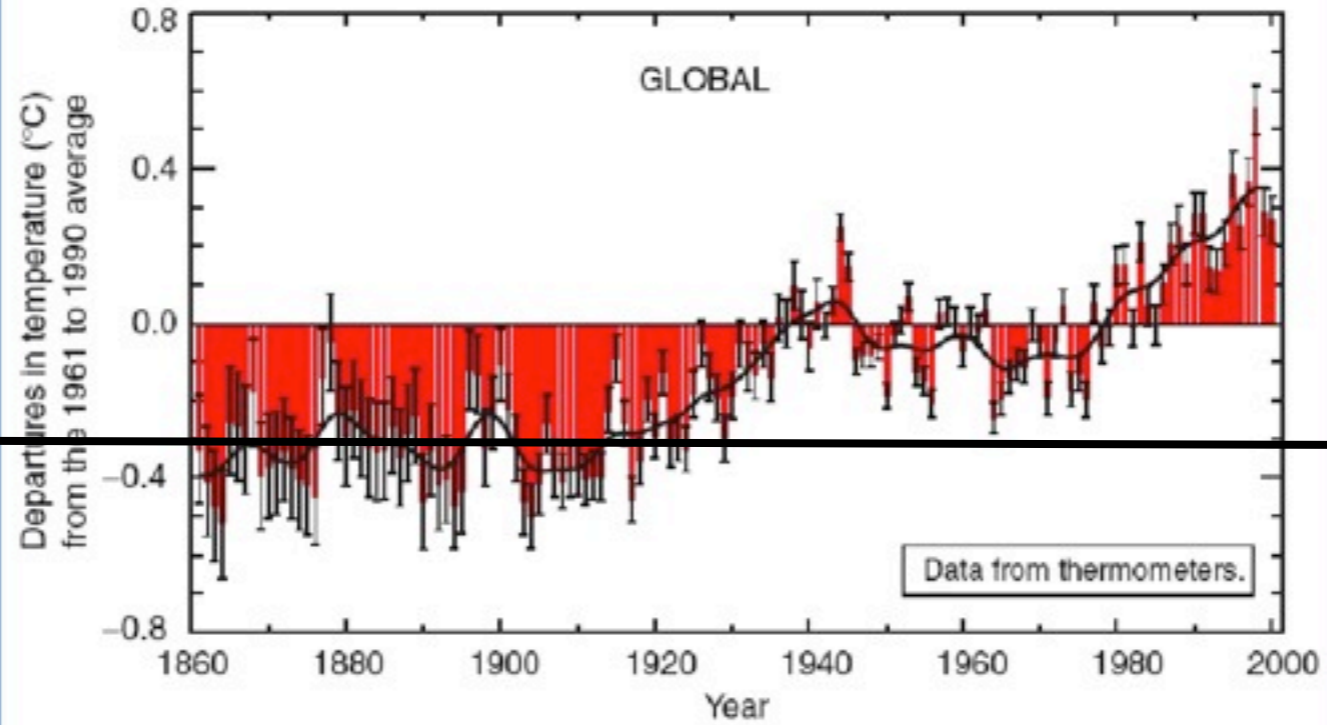

-0.3°C

(b) the past 1,000 years

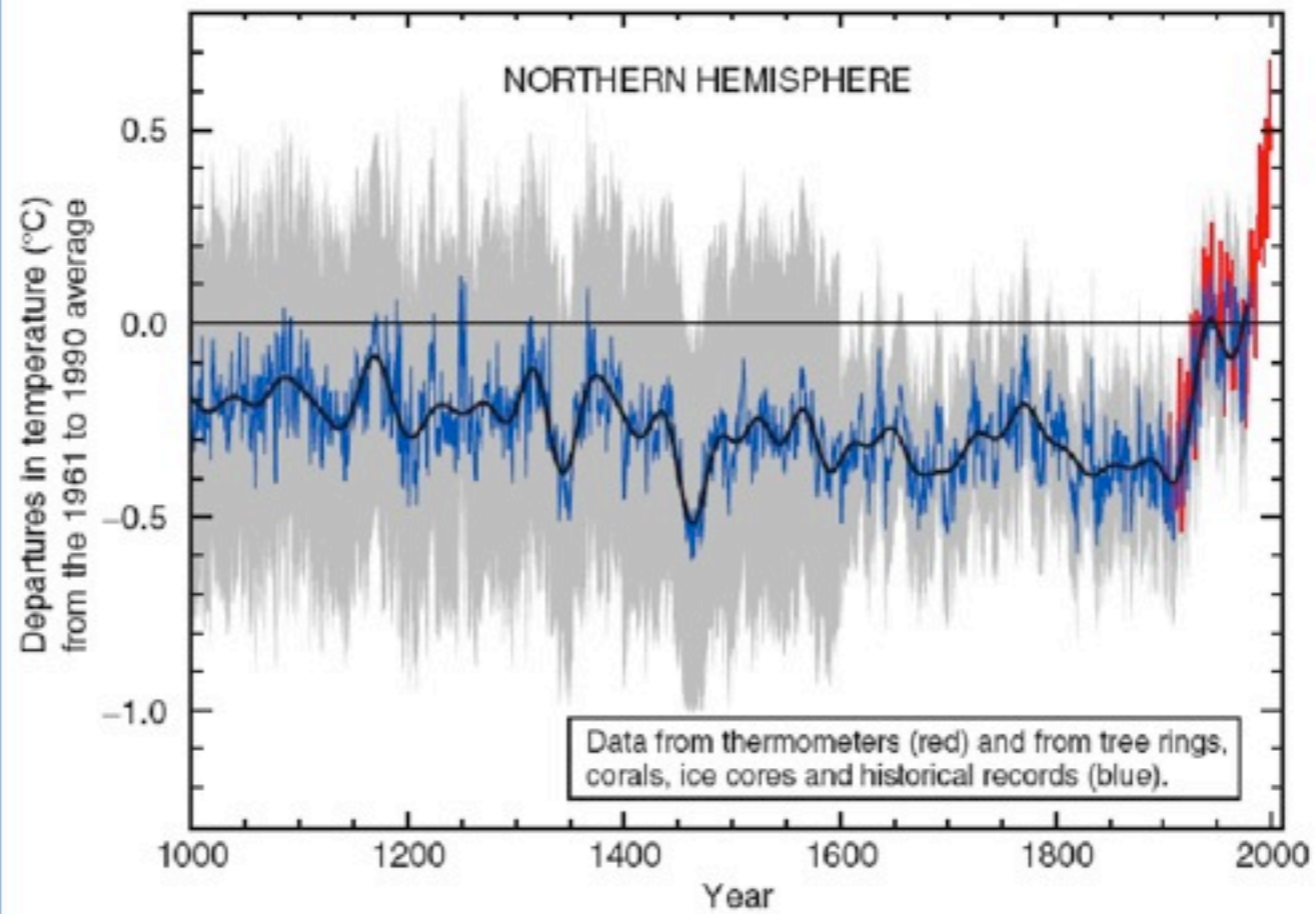



# Variations of the Earth's surface temperature for:

(a) the past 140 years

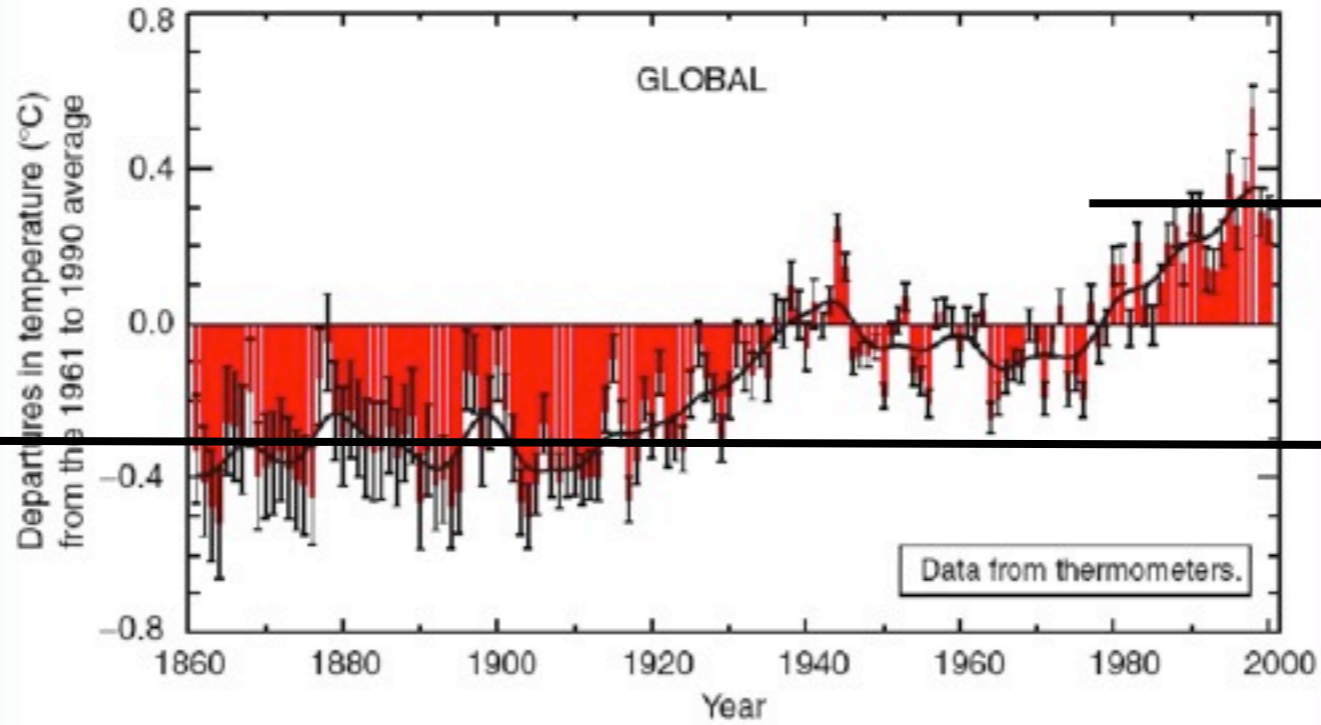

-0.3°C

+0.3°C

(b) the past 1,000 years

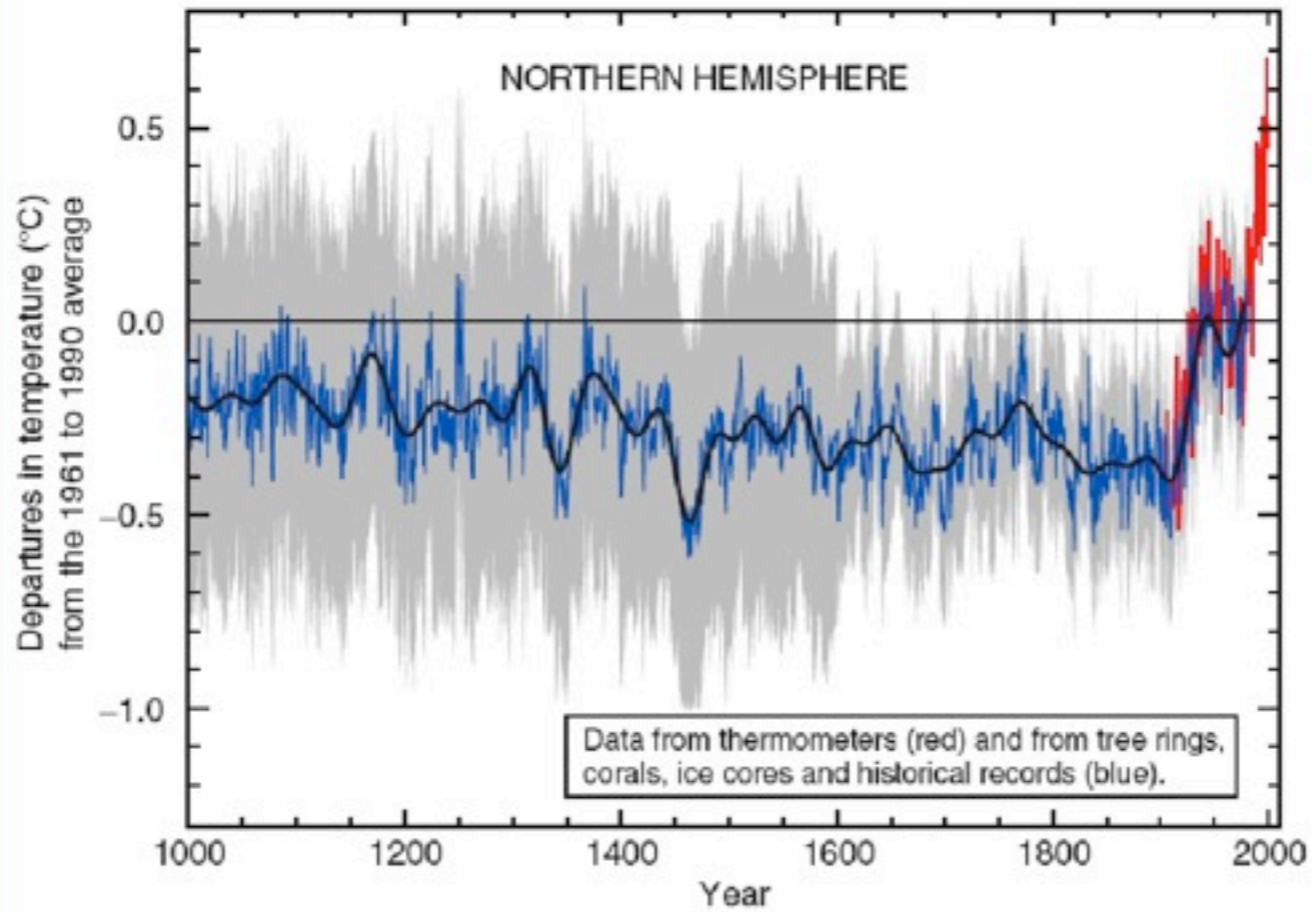

# Variations of the Earth's surface temperature for:

(a) the past 140 years

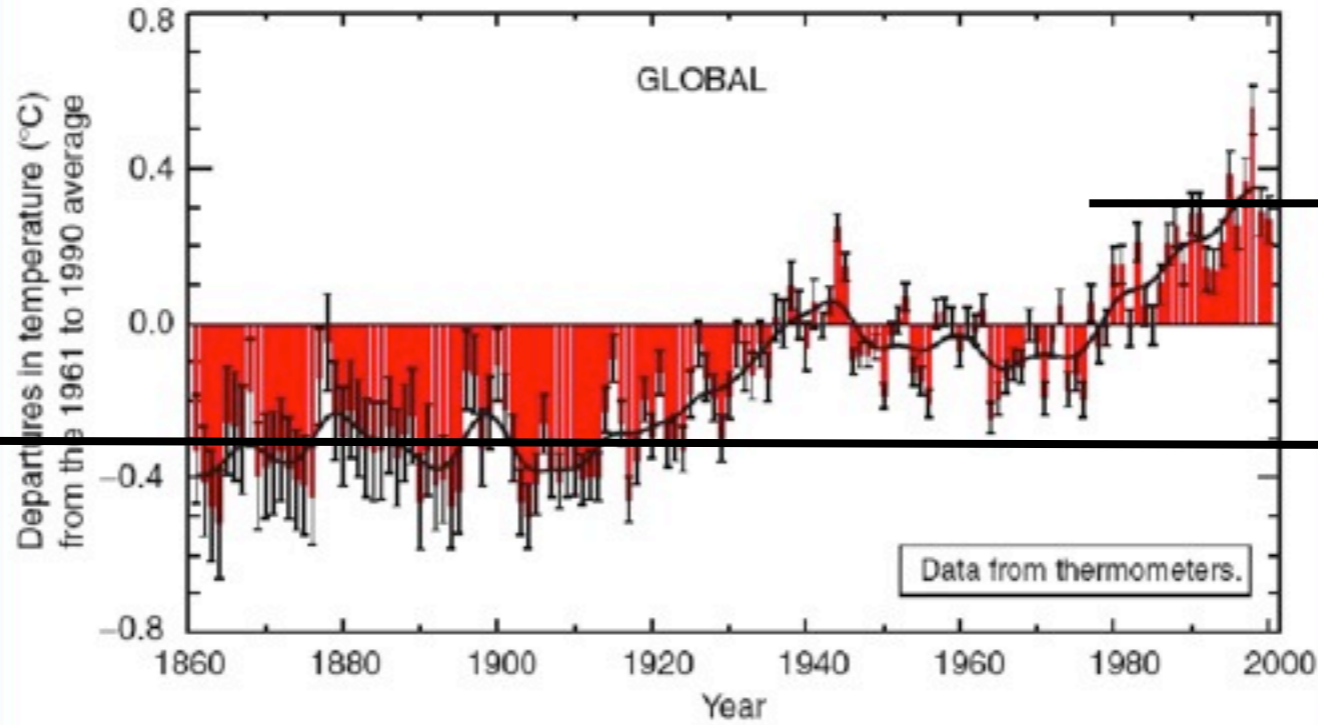

-0.3°C

+0.3°C

0.6°C  
warming  
This is not  
very  
convincing.

(b) the past 1,000 years

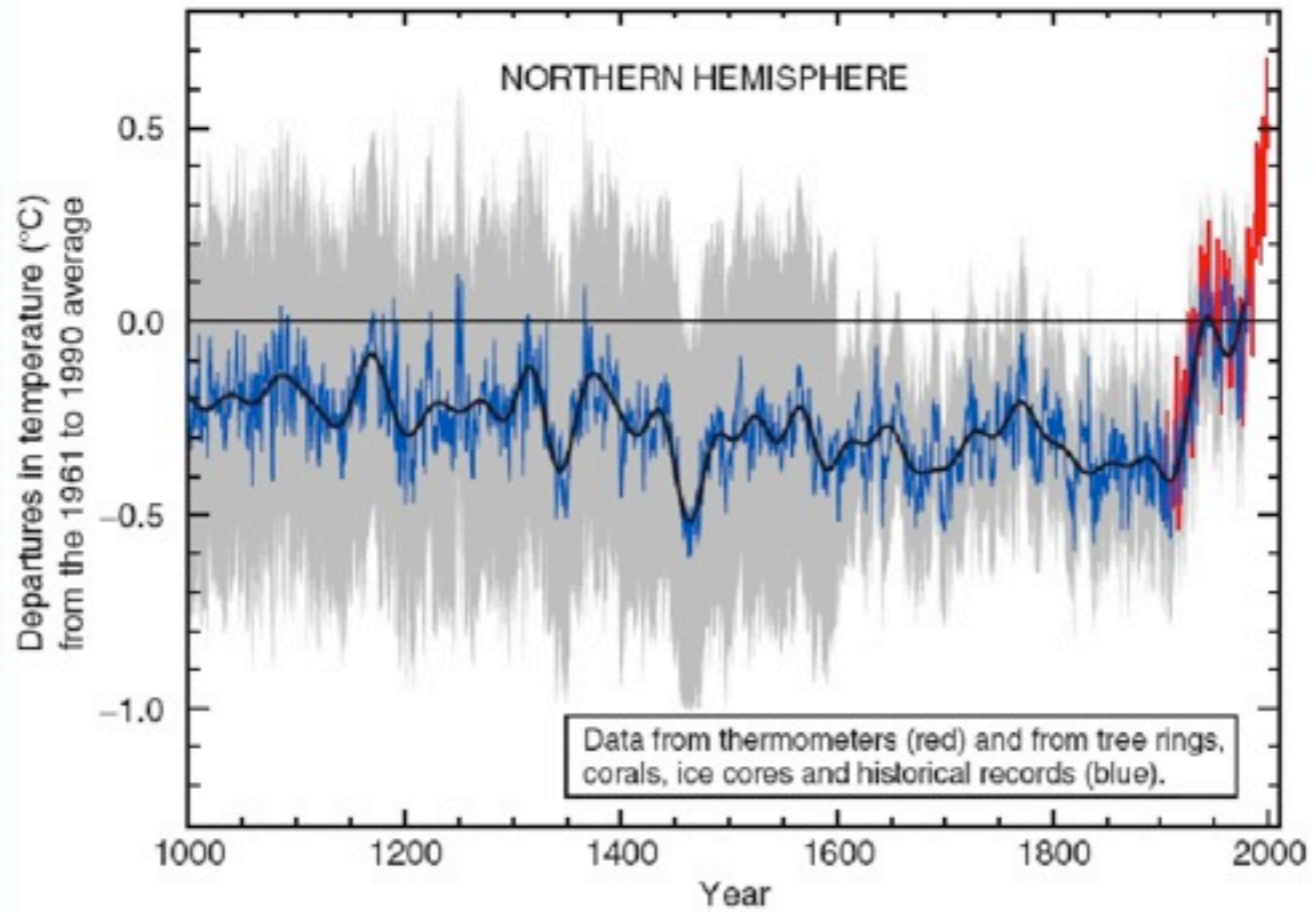

# Variations of the Earth's surface temperature for:

(a) the past 140 years

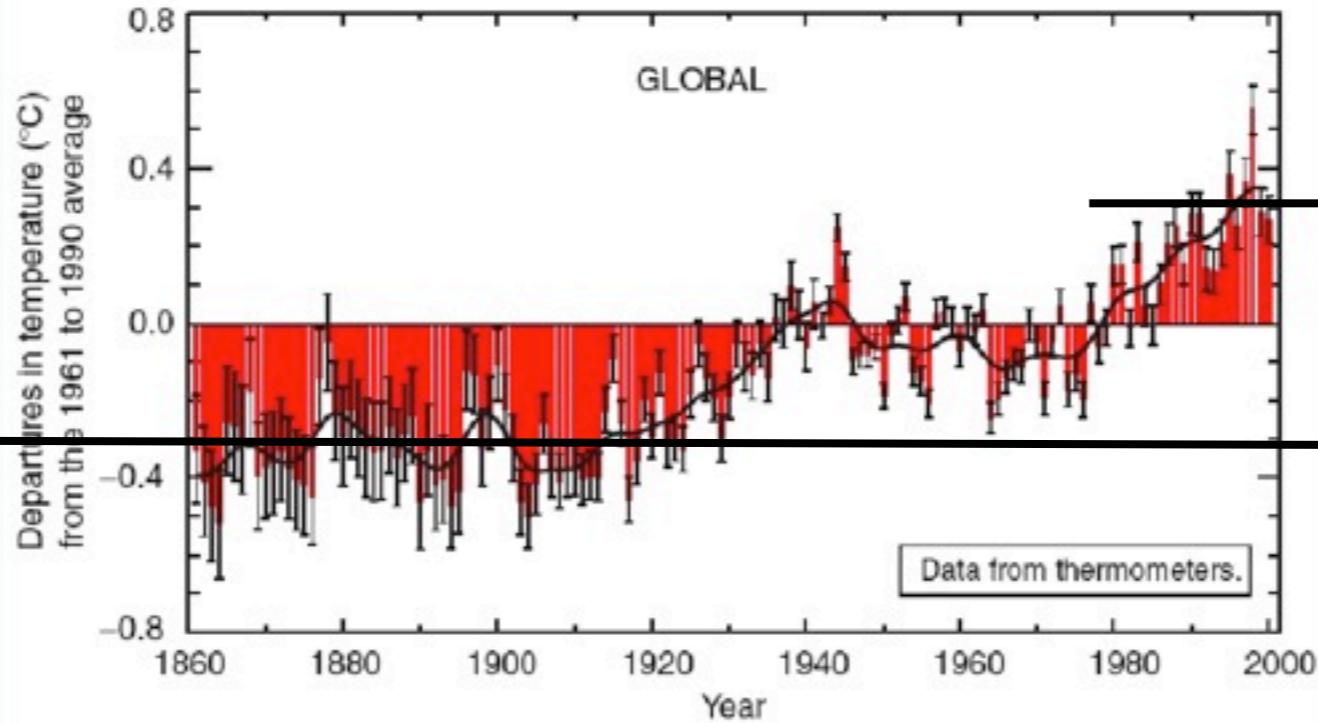

-0.3°C

+0.3°C

0.6°C  
warming  
This is not  
very  
convincing.

(b) the past 1,000 years

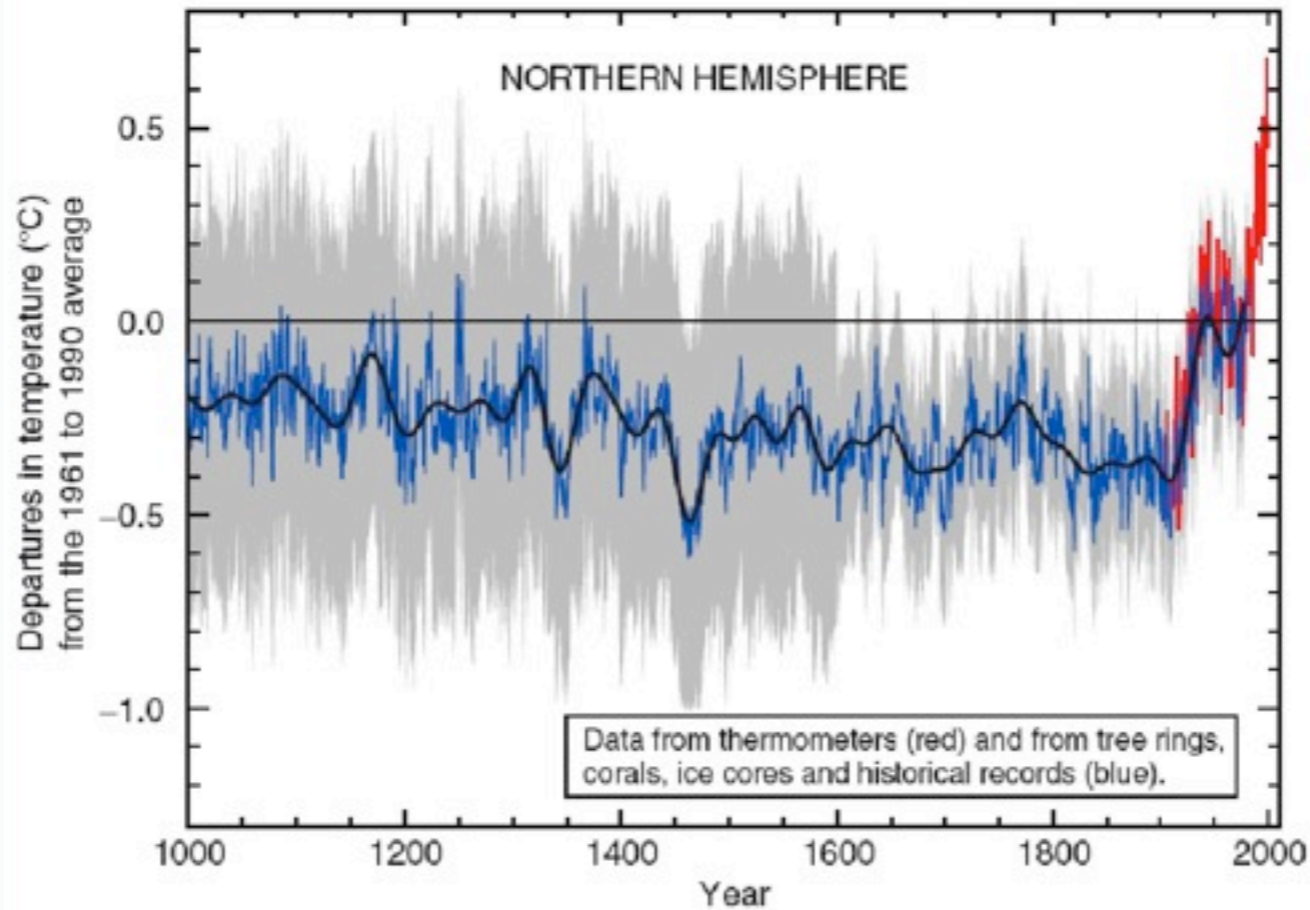

The "hockey stick"  
curve; sea level has  
the same shape.



# Simulated annual global mean surface temperatures

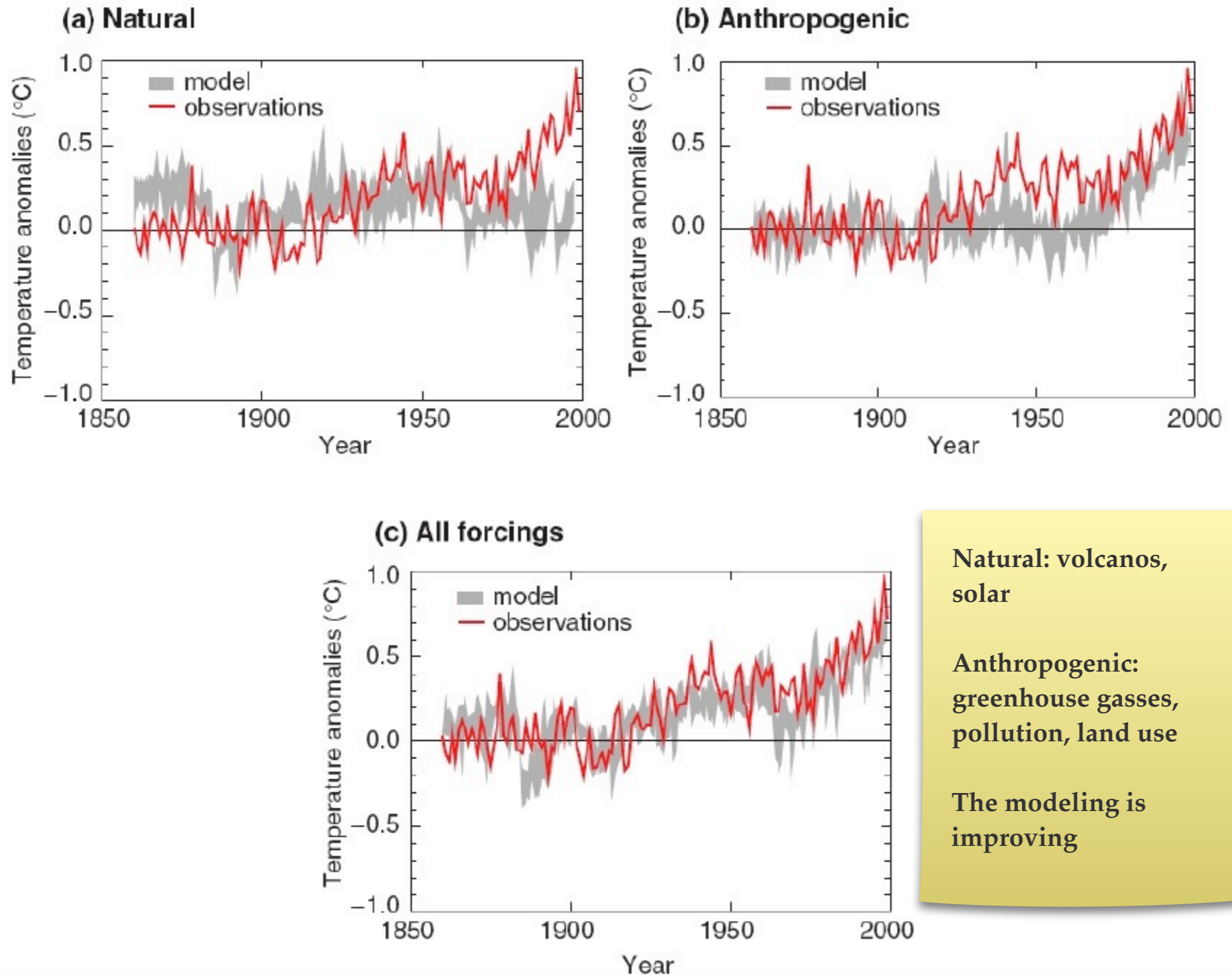
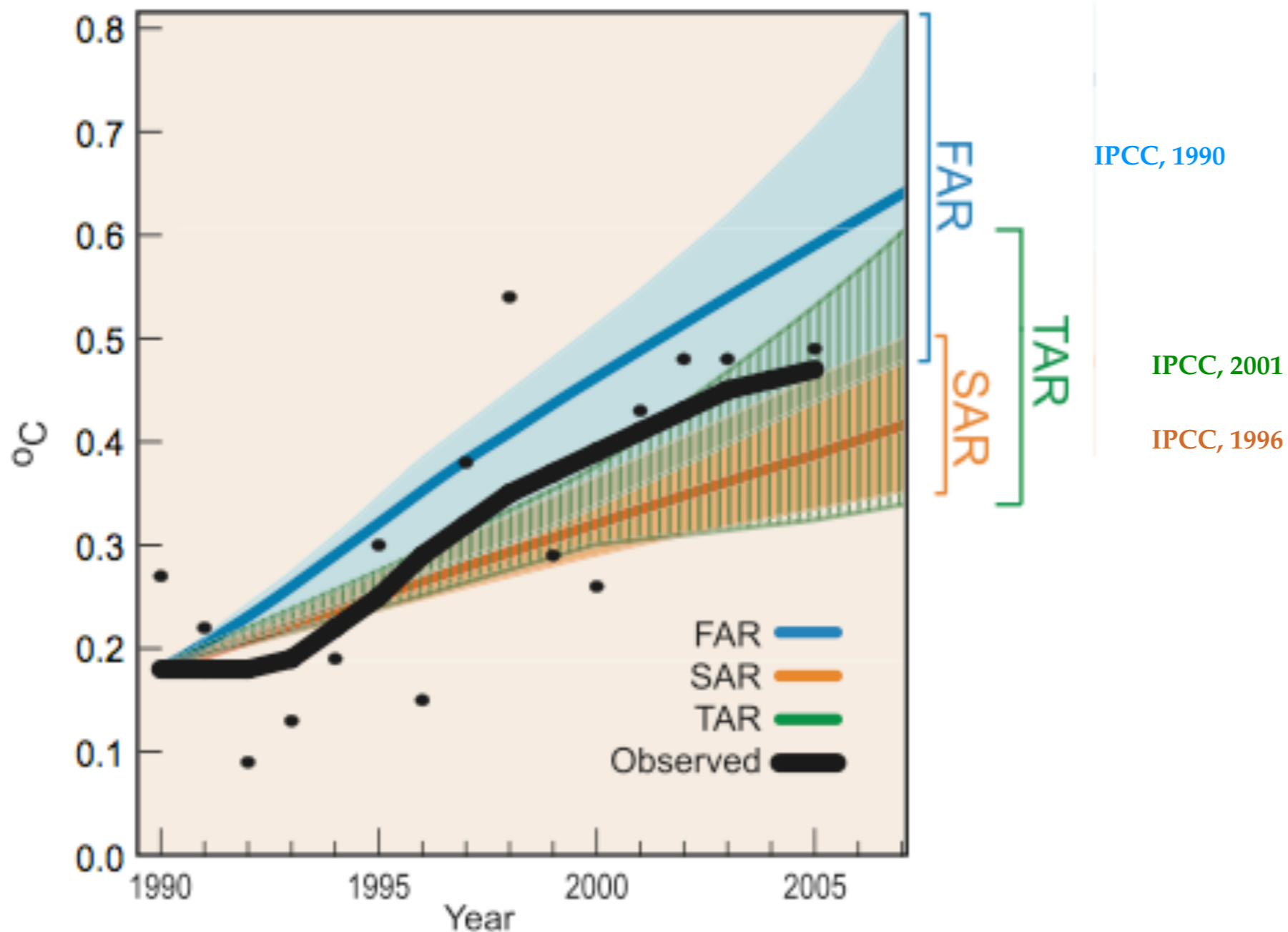
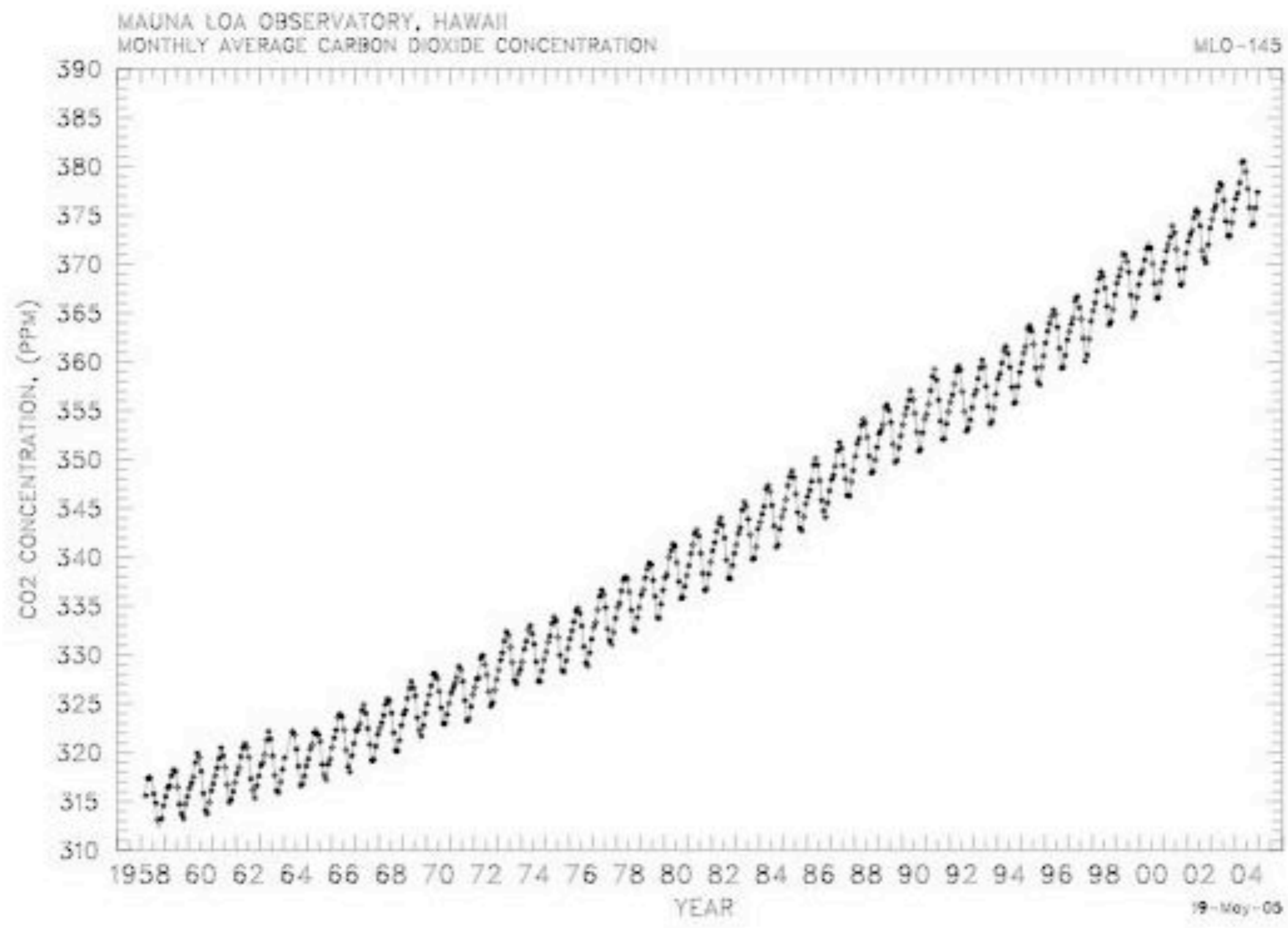

Figure 4: Simulating the Earth's temperature variations, and comparing the results to measured changes, can provide insight into the underlying causes of the major changes.



**Figure 1.1.** Yearly global average surface temperature (Brohan et al., 2006), relative to the mean 1961 to 1990 values, and as projected in the FAR (IPCC, 1990), SAR (IPCC, 1996) and TAR (IPCC, 2001a). The 'best estimate' model projections from the FAR and SAR are in solid lines with their range of estimated projections shown by the shaded areas. The TAR did not have 'best estimate' model projections but rather a range of projections. Annual mean observations (Section 3.2) are depicted by black circles and the thick black line shows decadal variations obtained by smoothing the time series using a 13-point filter.

This is the measurement from Mauna Loa.





# This is the measurement from Mauna Loa.

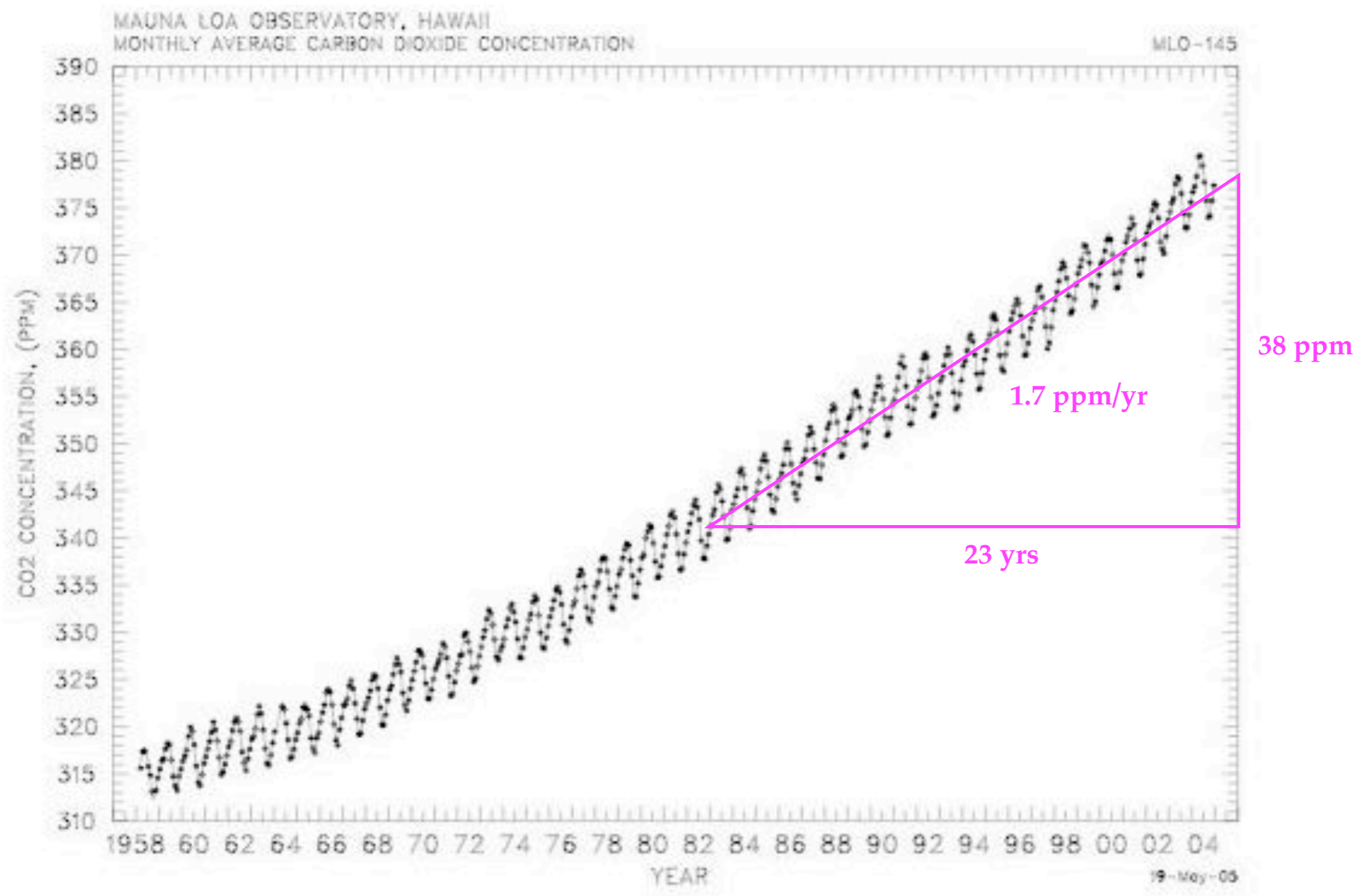

# This is the measurement from Mauna Loa.

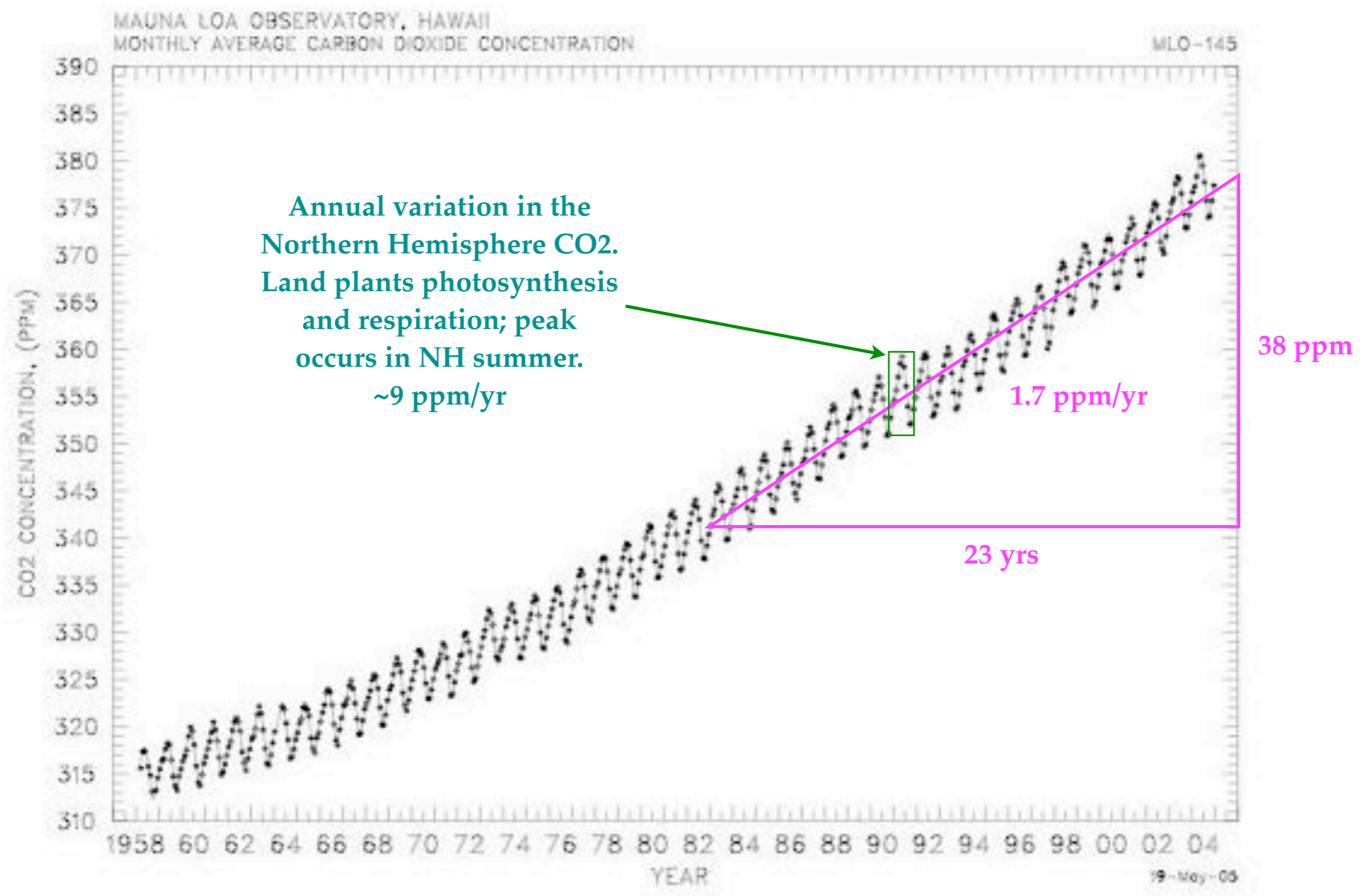

From IPCC 2001

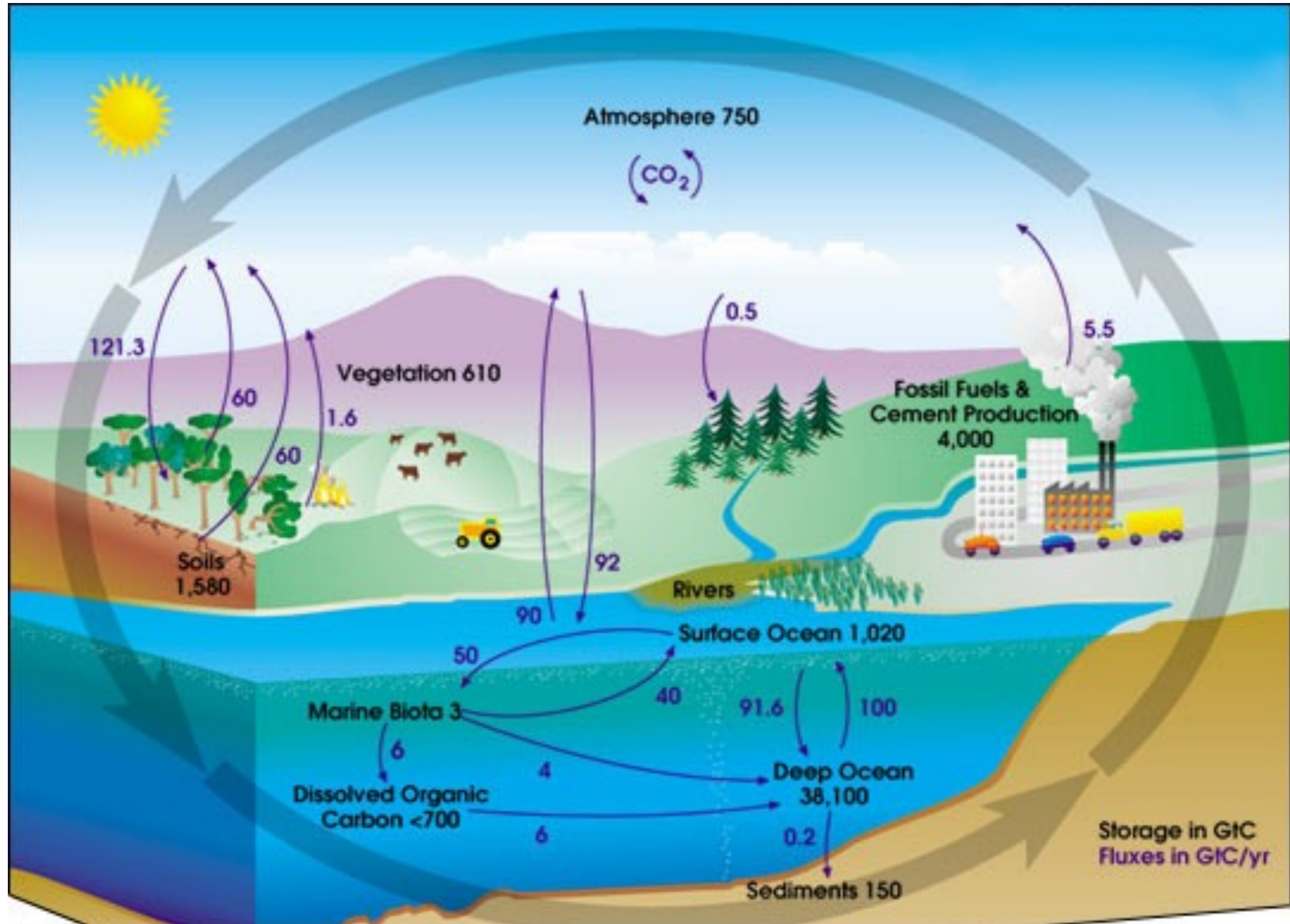

The Carbon Cycle



# From Schlesinger 1991

Simplified using only the most active exchanges; no very long time scale exchanges.

Small quantitative differences.

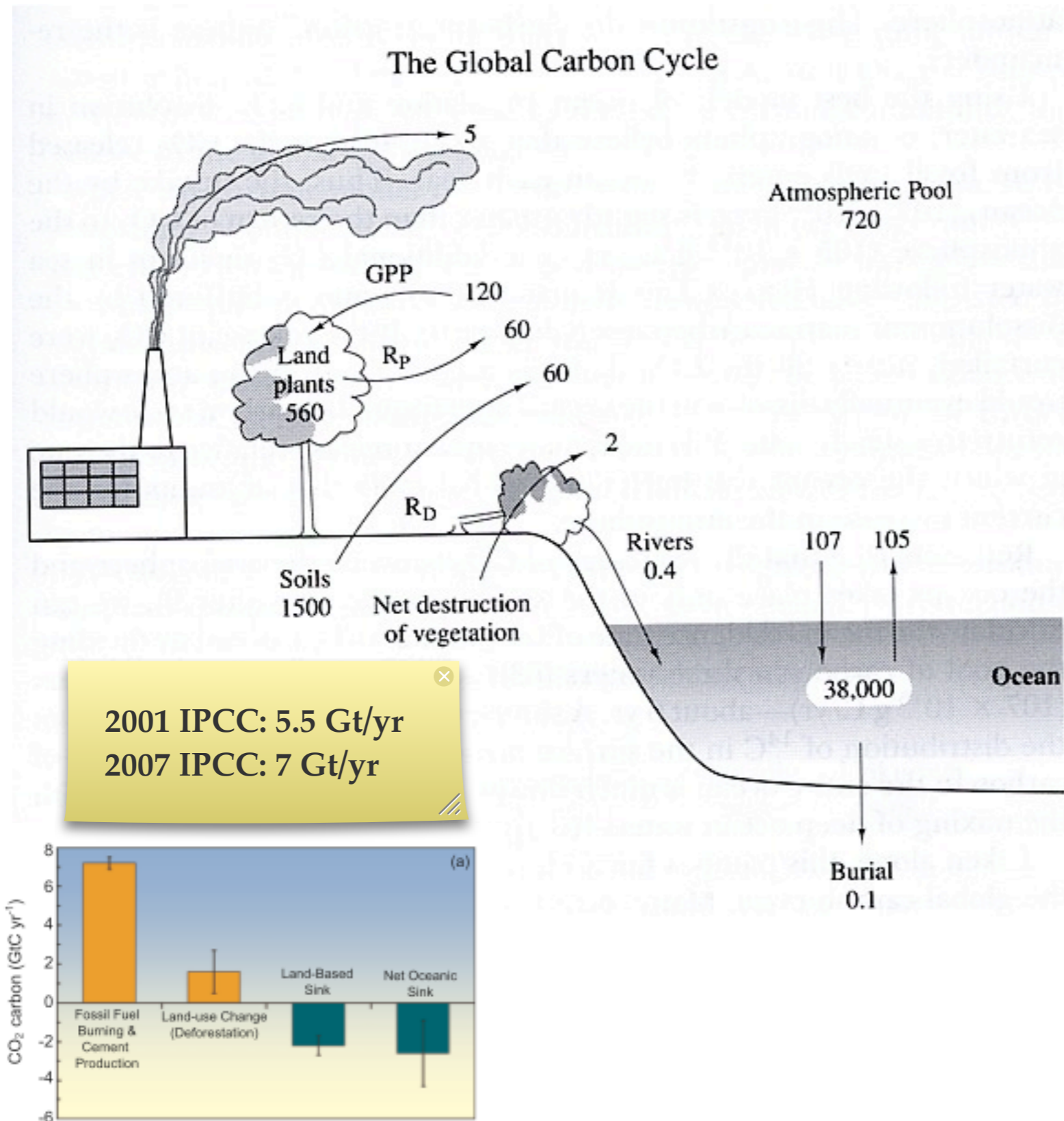

Ocean Exchange	+105 -107
Vegetation Loss	+2
Soils	+60
Land Plants	+60 -120
Fossil Fuels	+5
Net to Atmosphere	+5

We can create a simple computer model using STELLA to test the carbon cycle as given.

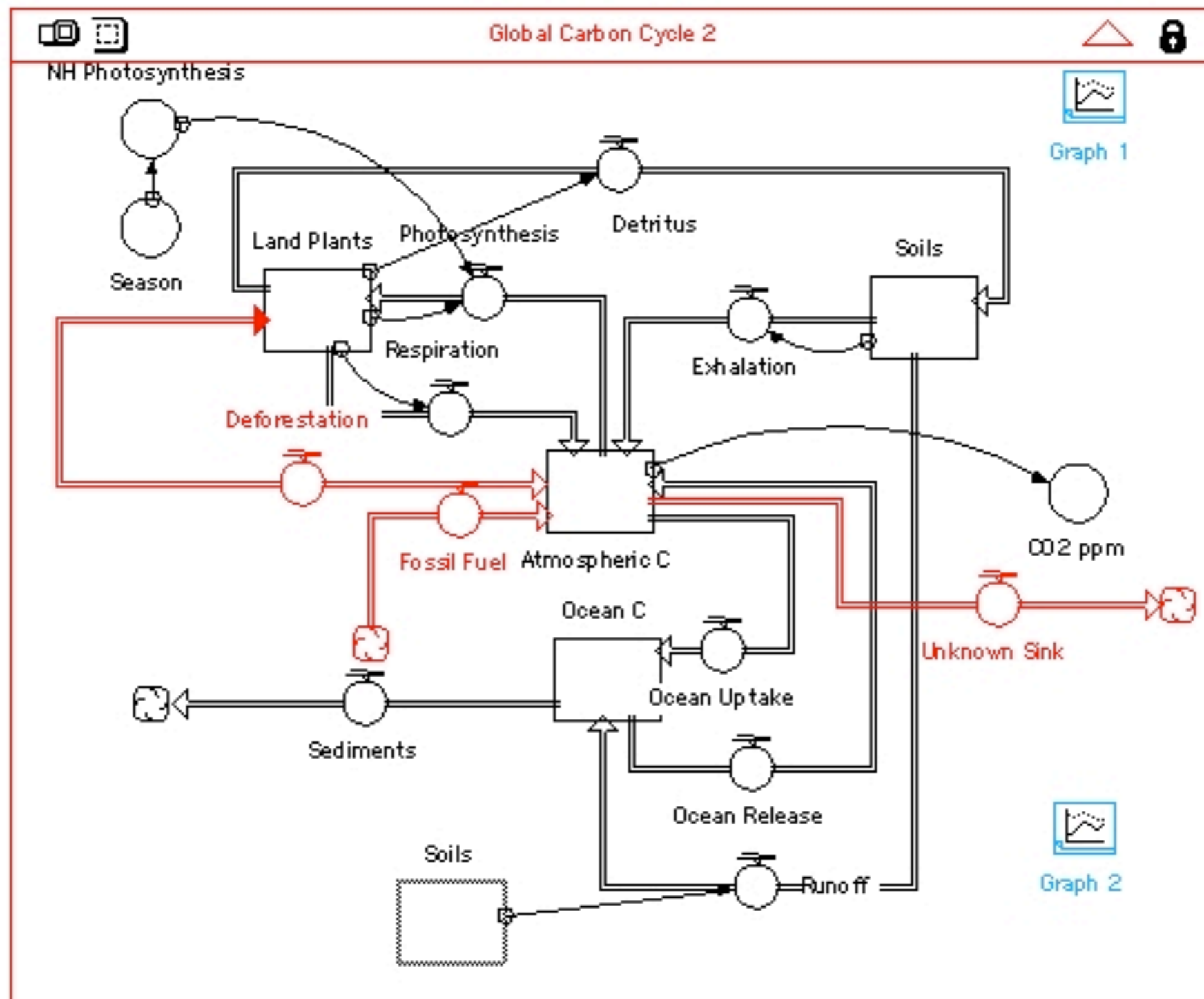

We can create a simple computer model using STELLA to test the carbon cycle as given.

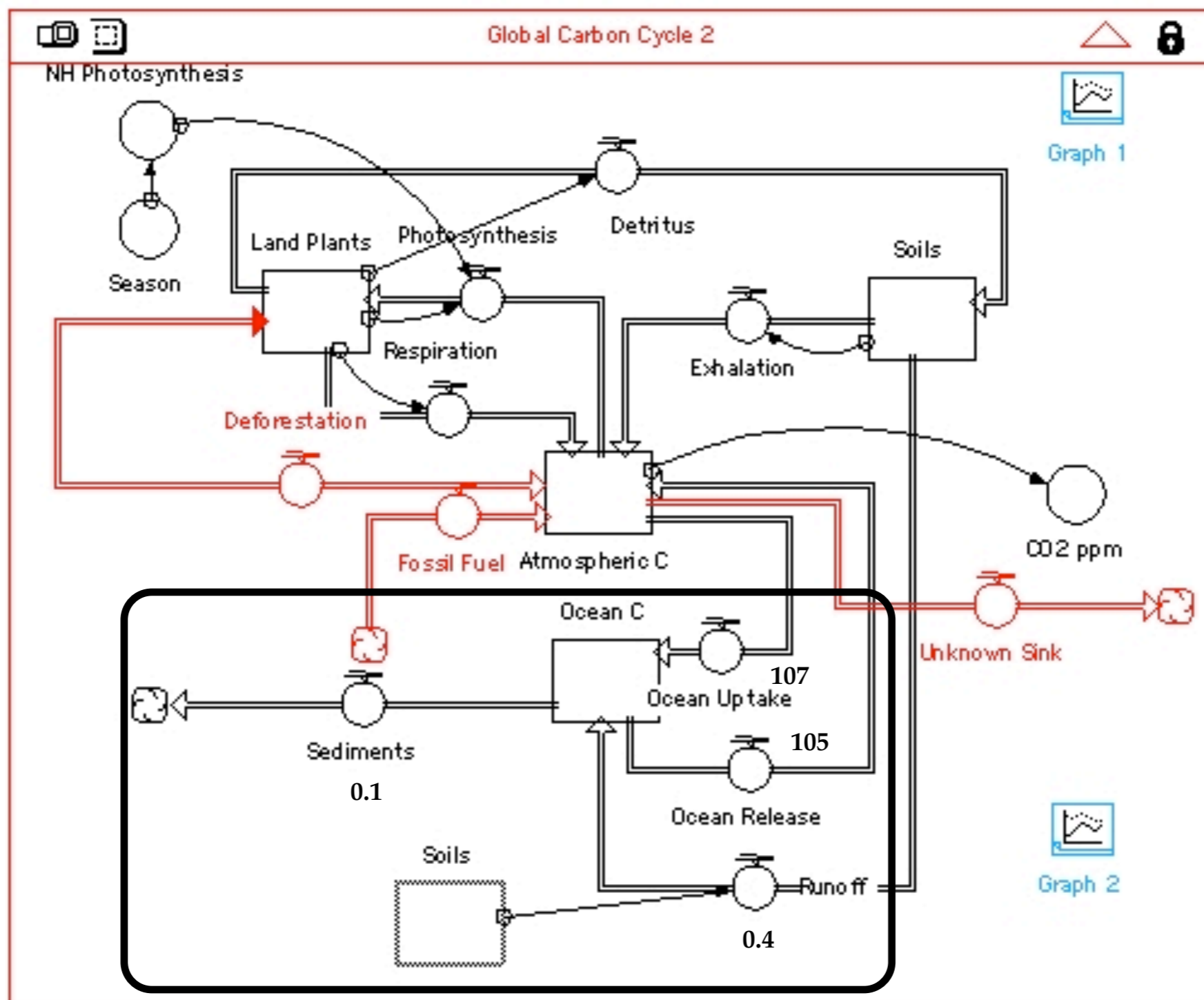



We can create a simple computer model using STELLA to test the carbon cycle as given.

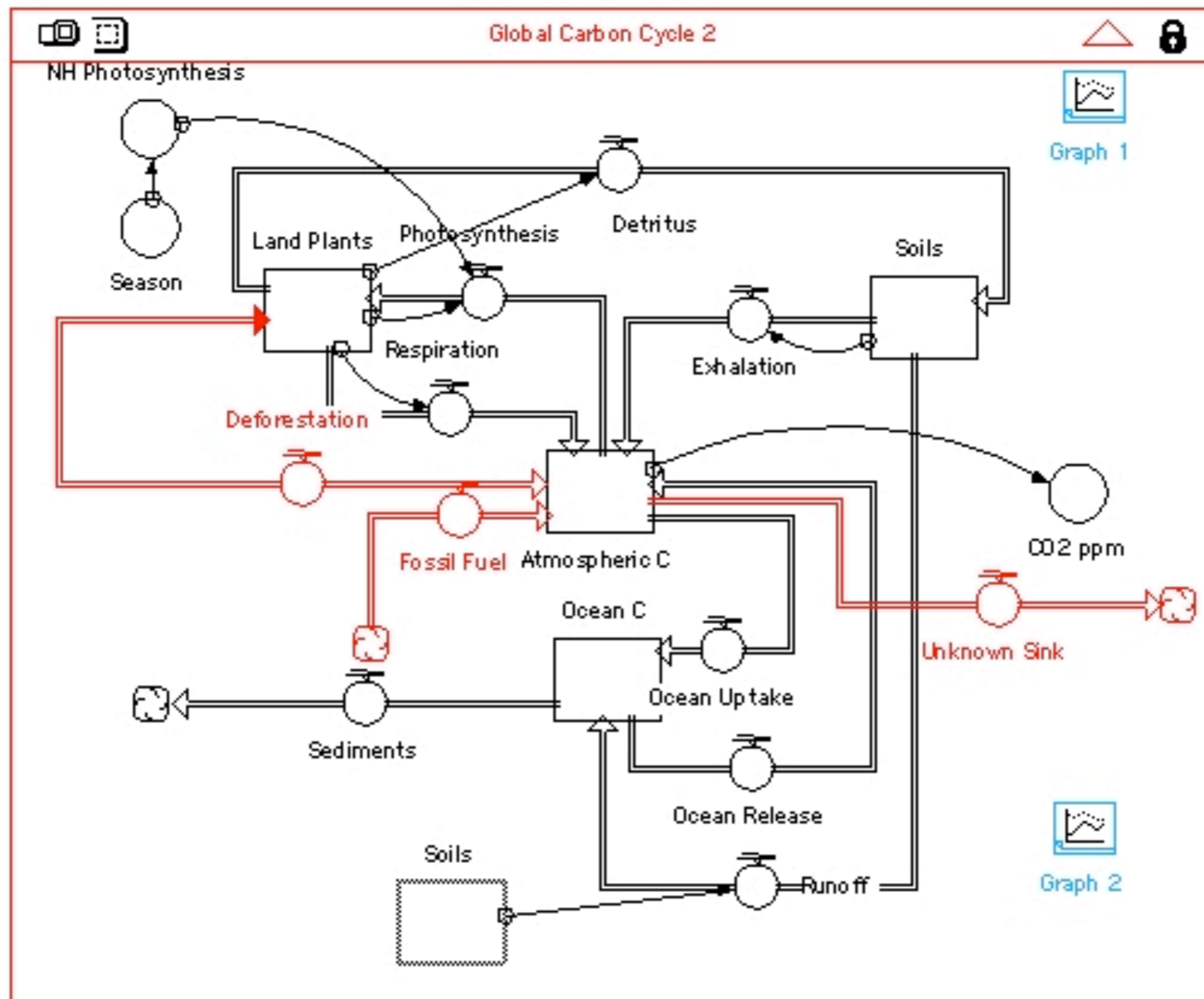

We can create a simple computer model using STELLA to test the carbon cycle as given.

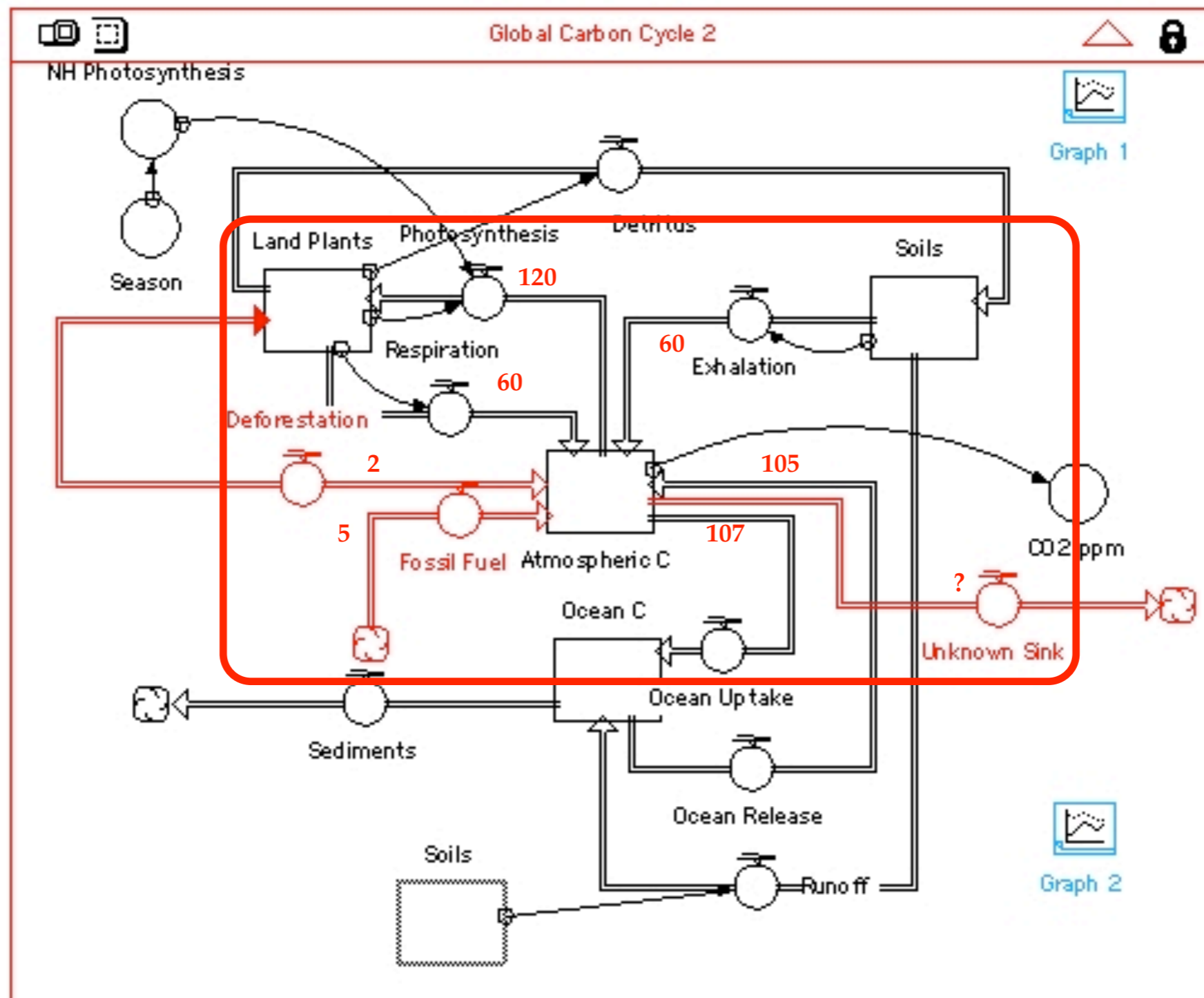

We can create a simple computer model using STELLA to test the carbon cycle as given.

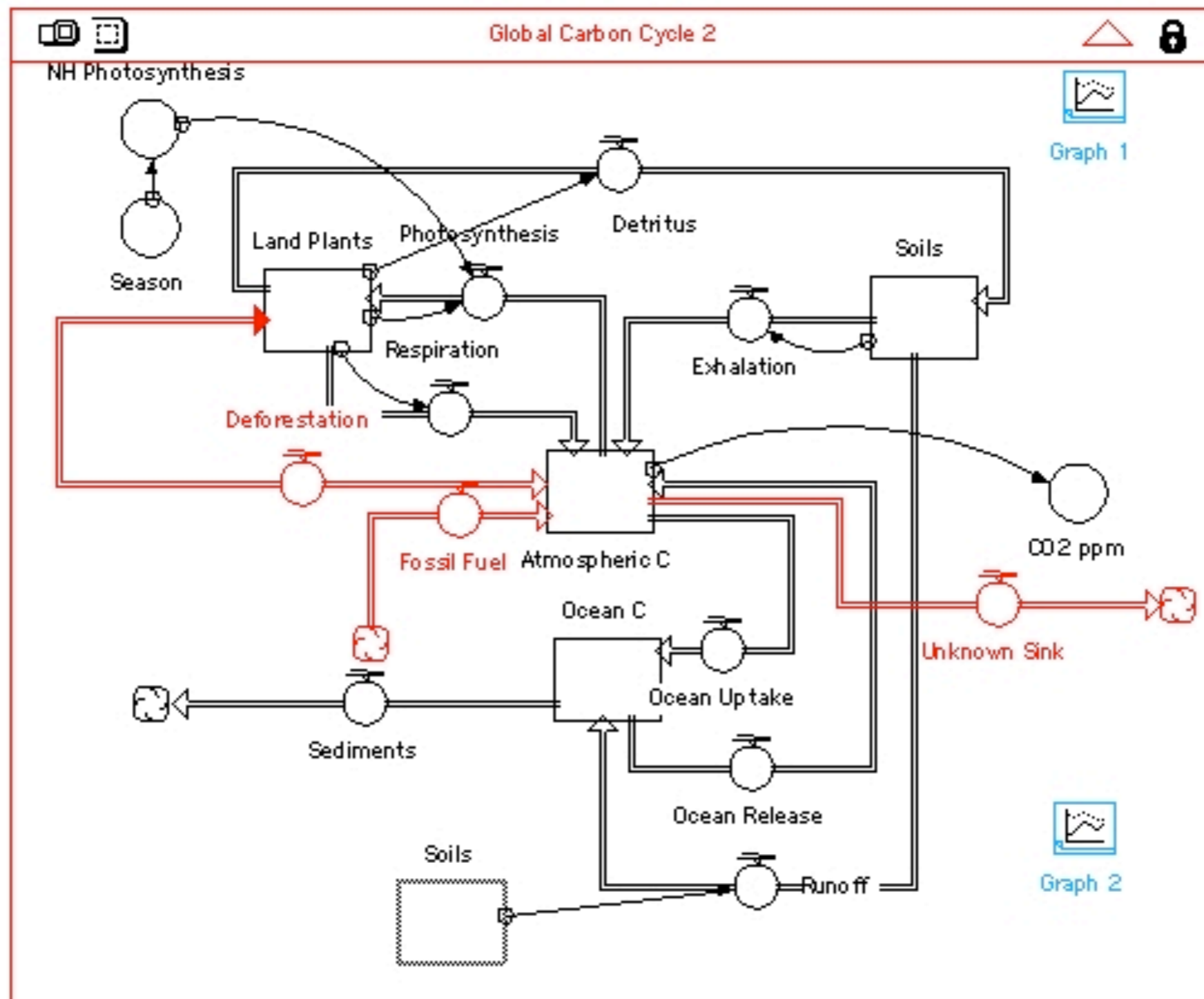



We can create a simple computer model using STELLA to test the carbon cycle as given.

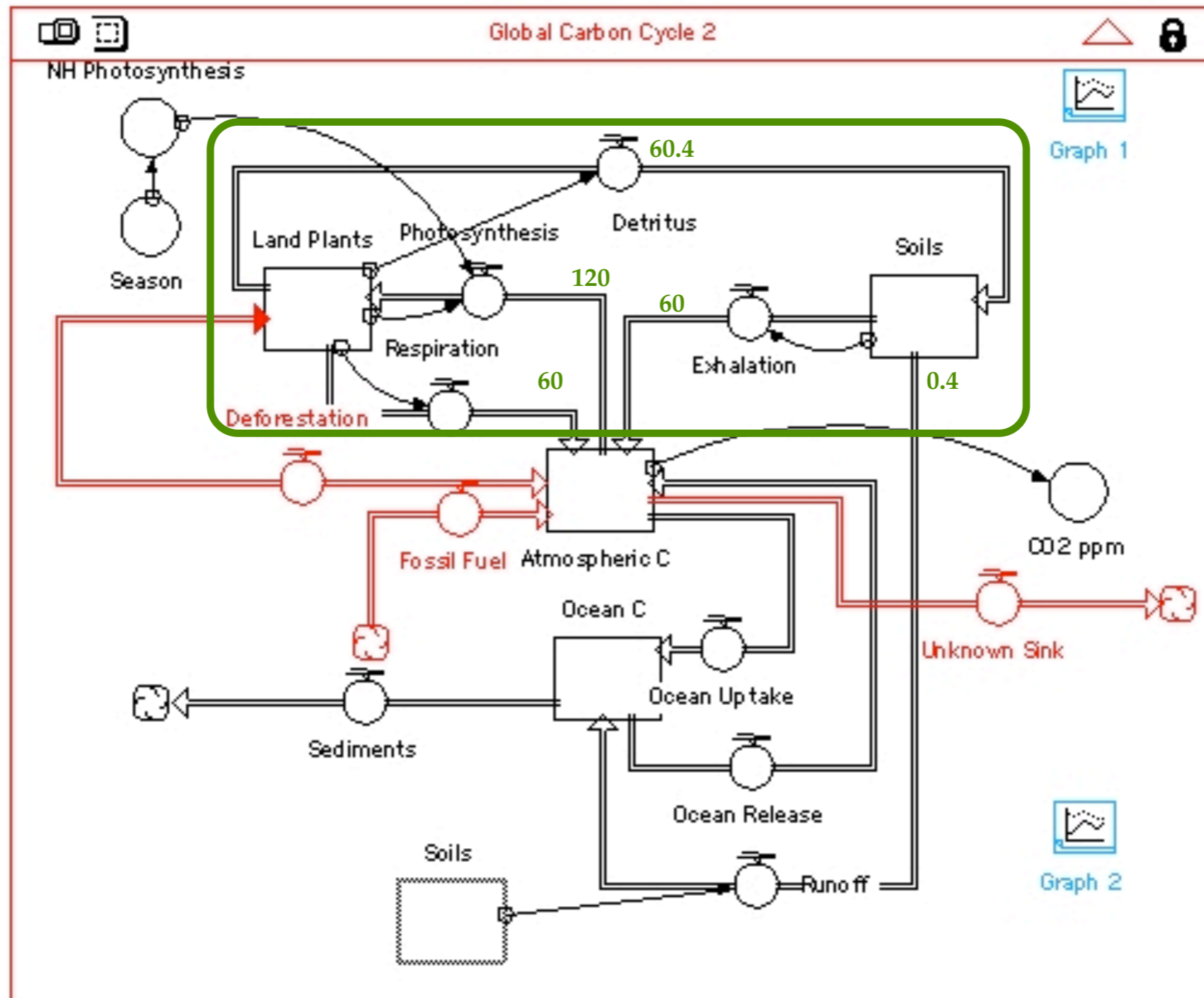

We can create a simple computer model using STELLA to test the carbon cycle as given.

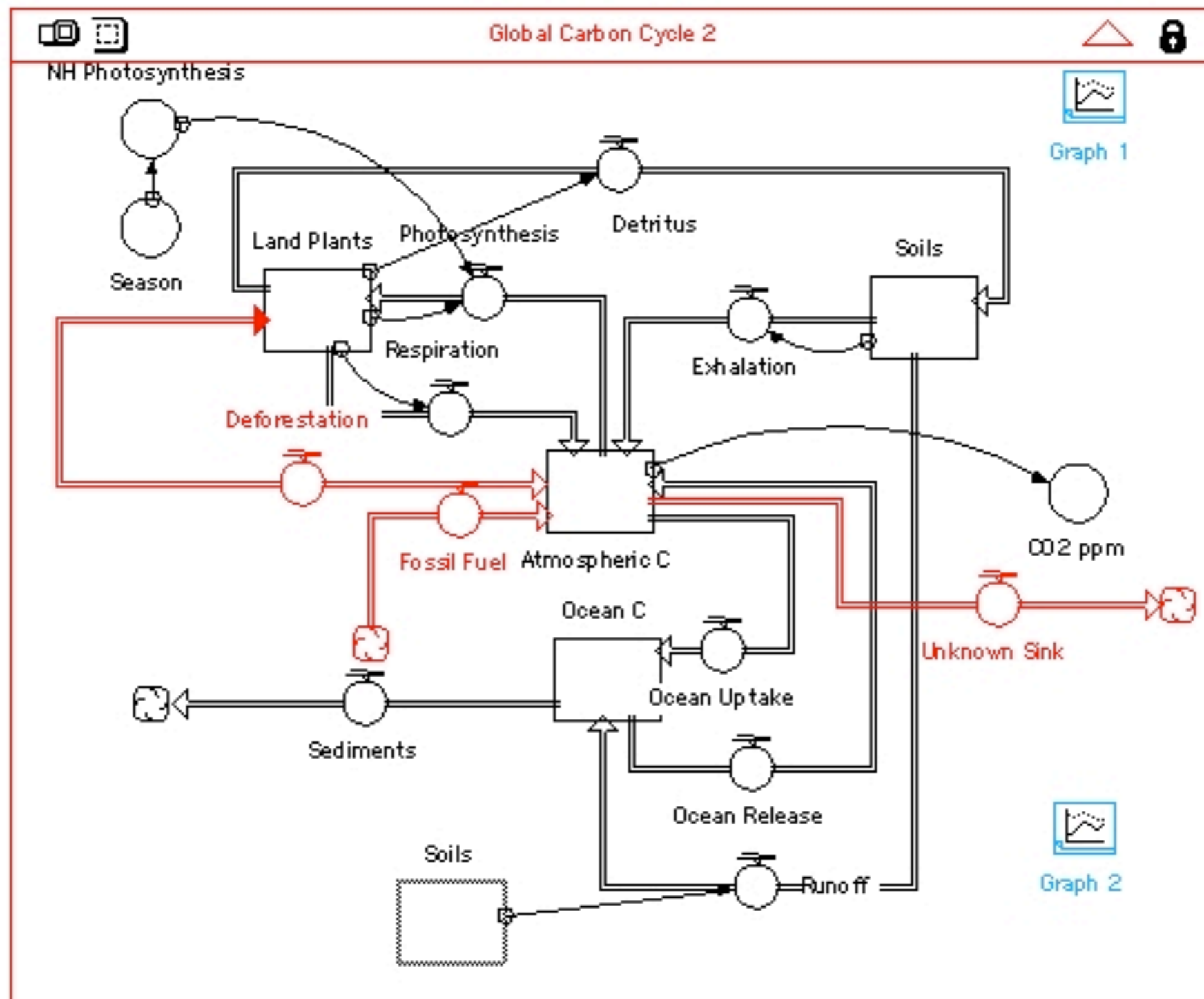

We can create a simple computer model using STELLA to test the carbon cycle as given.

This routine introduces seasonal variations into the photosynthesis rate

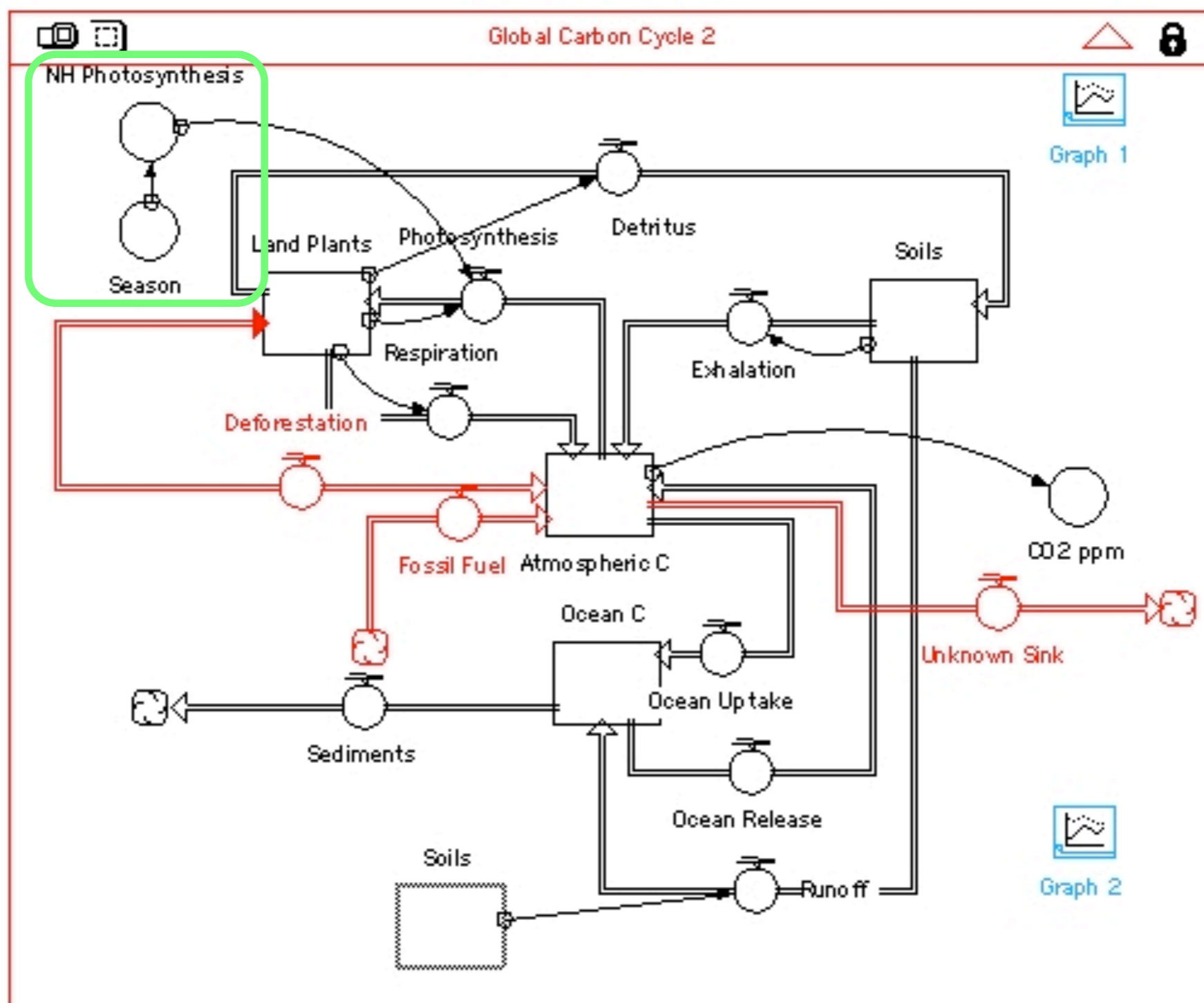



We can create a simple computer model using STELLA to test the carbon cycle as given.

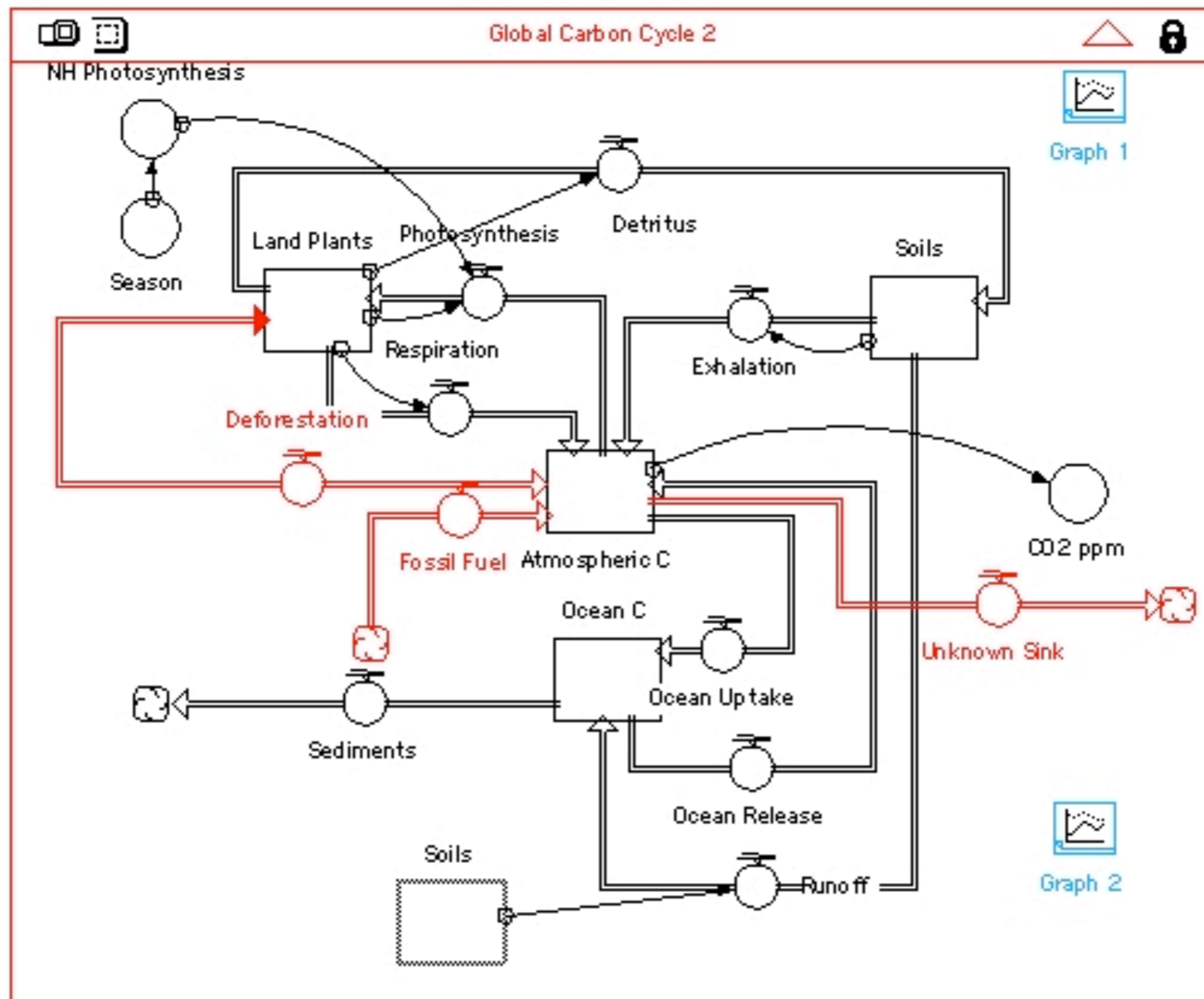

We can create a simple computer model using STELLA to test the carbon cycle as given.

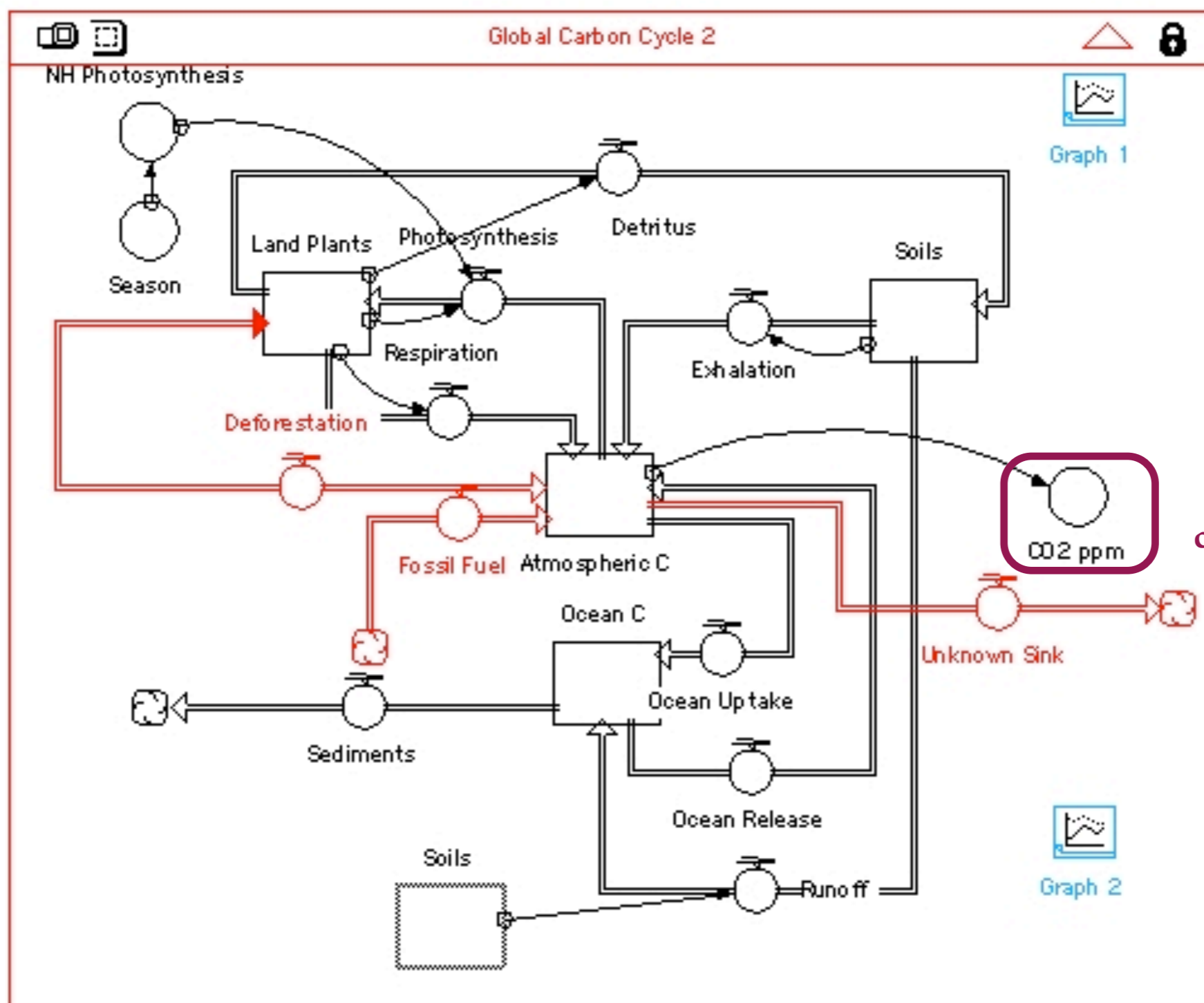

This computation converts Gt to ppm

We can create a simple computer model using STELLA to test the carbon cycle as given.

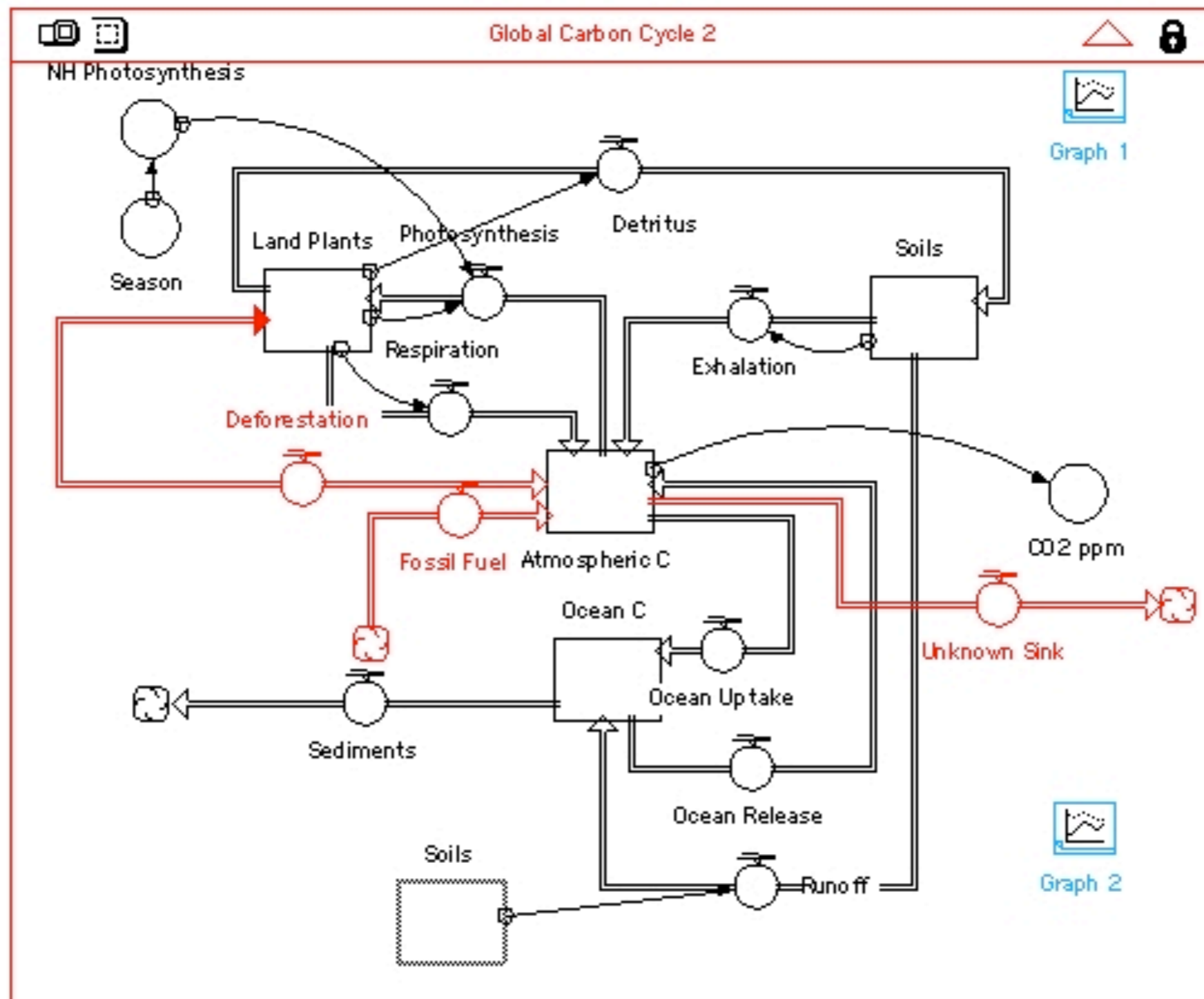



This is the measurement from Mauna Loa.

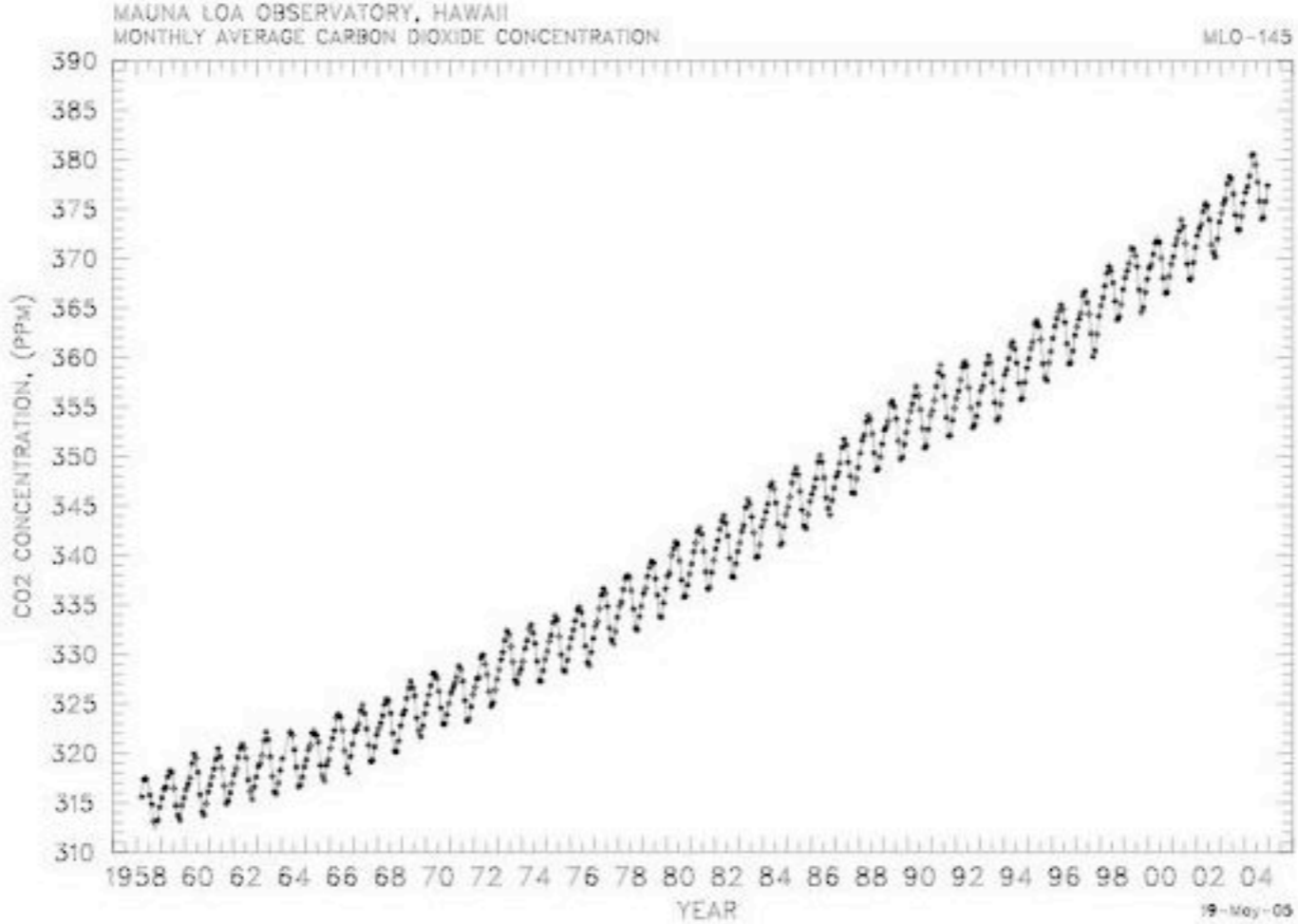

This is the measurement from Mauna Loa.

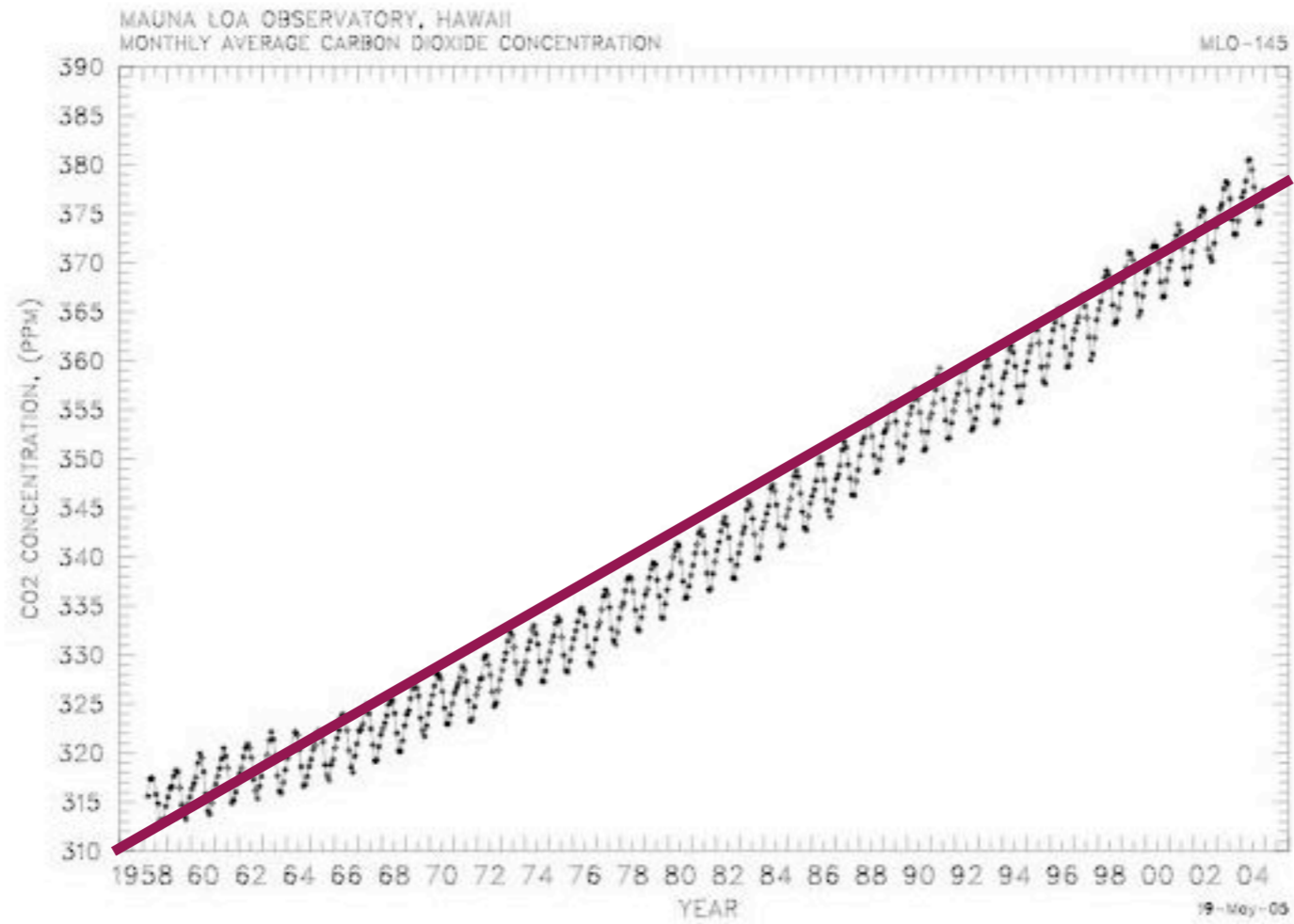

Net 46 yr increase in atmospheric CO<sub>2</sub>

## Model Runs changing the Unknown Sink





# Model Runs changing the Unknown Sink

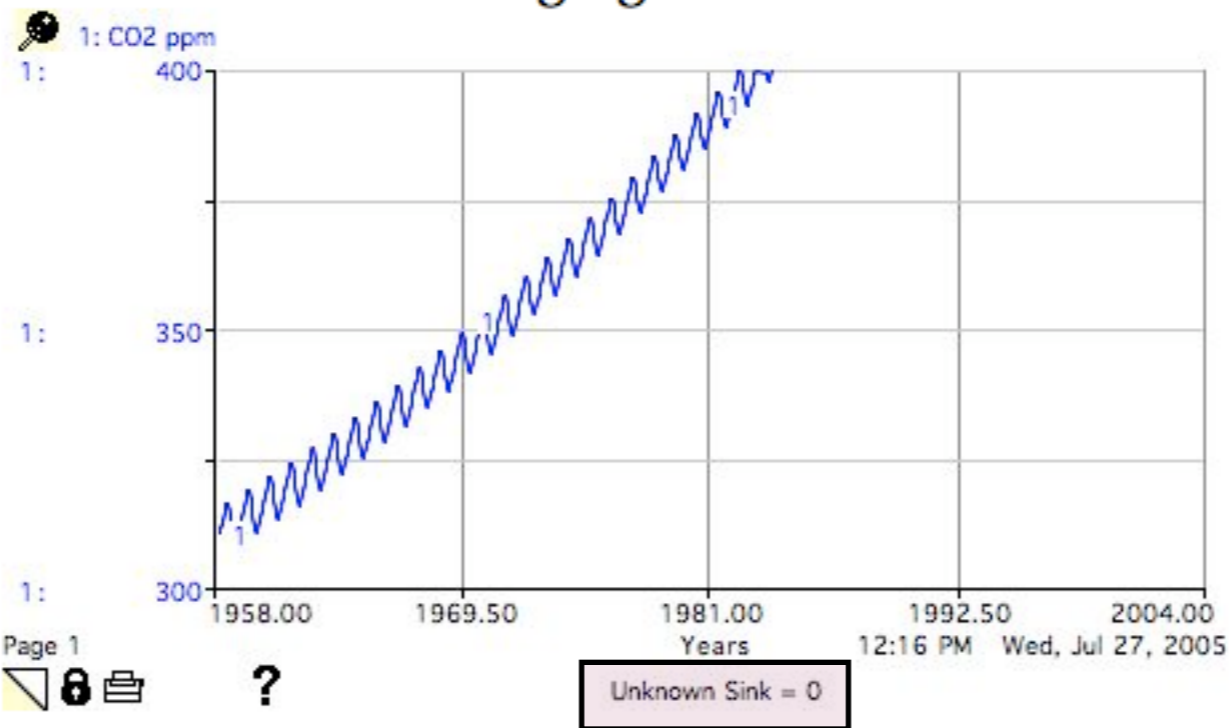

## Model Runs changing the Unknown Sink

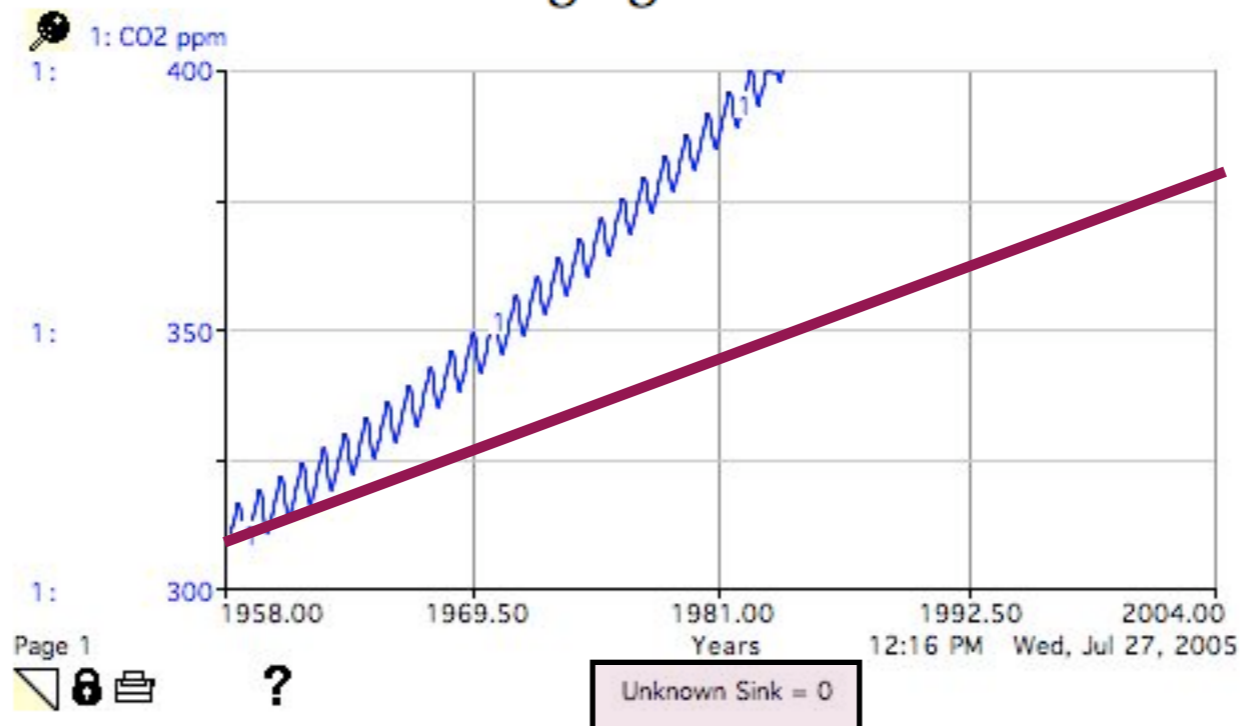

**If all of our carbon emissions stayed in the atmosphere the CO<sub>2</sub> would exceed the measured amount.**

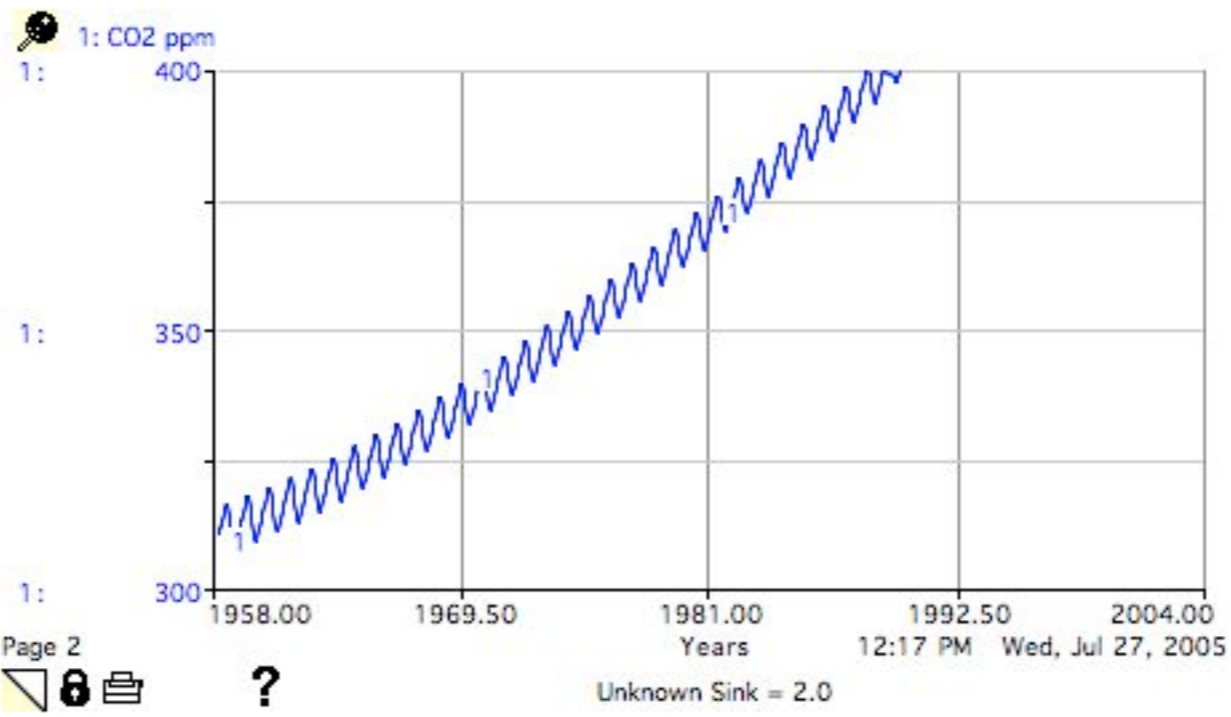



The previous result with  
Unknown Sink = 0

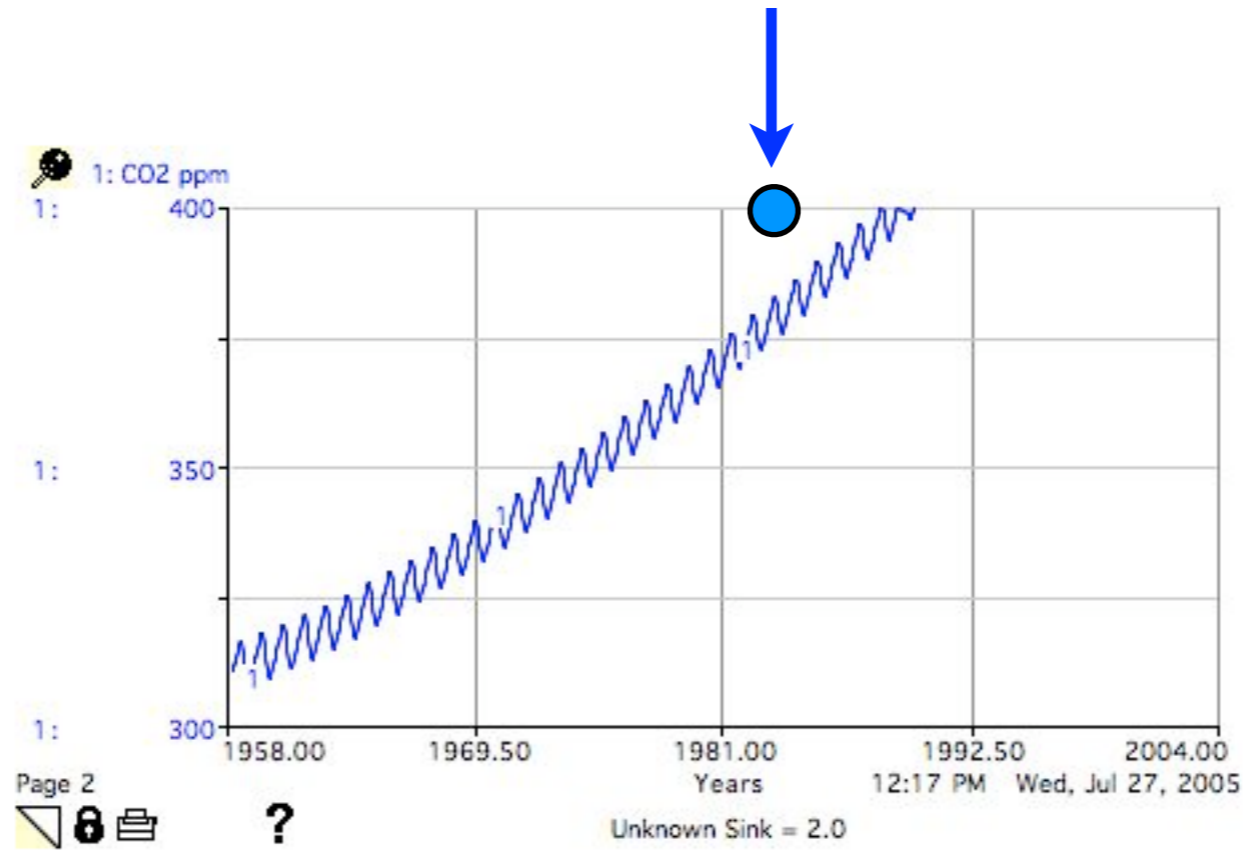

The previous result with  
Unknown Sink = 0

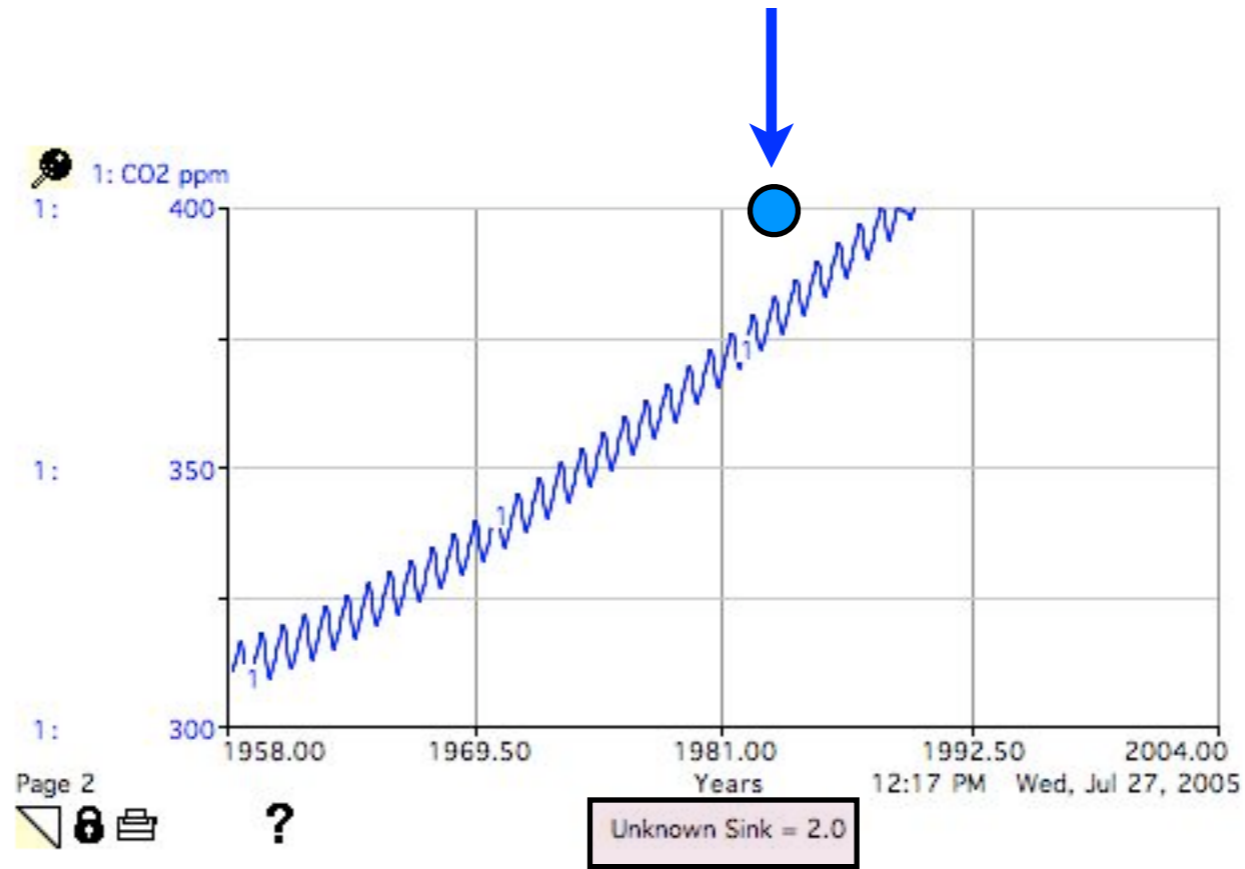

The previous result with  
Unknown Sink = 0

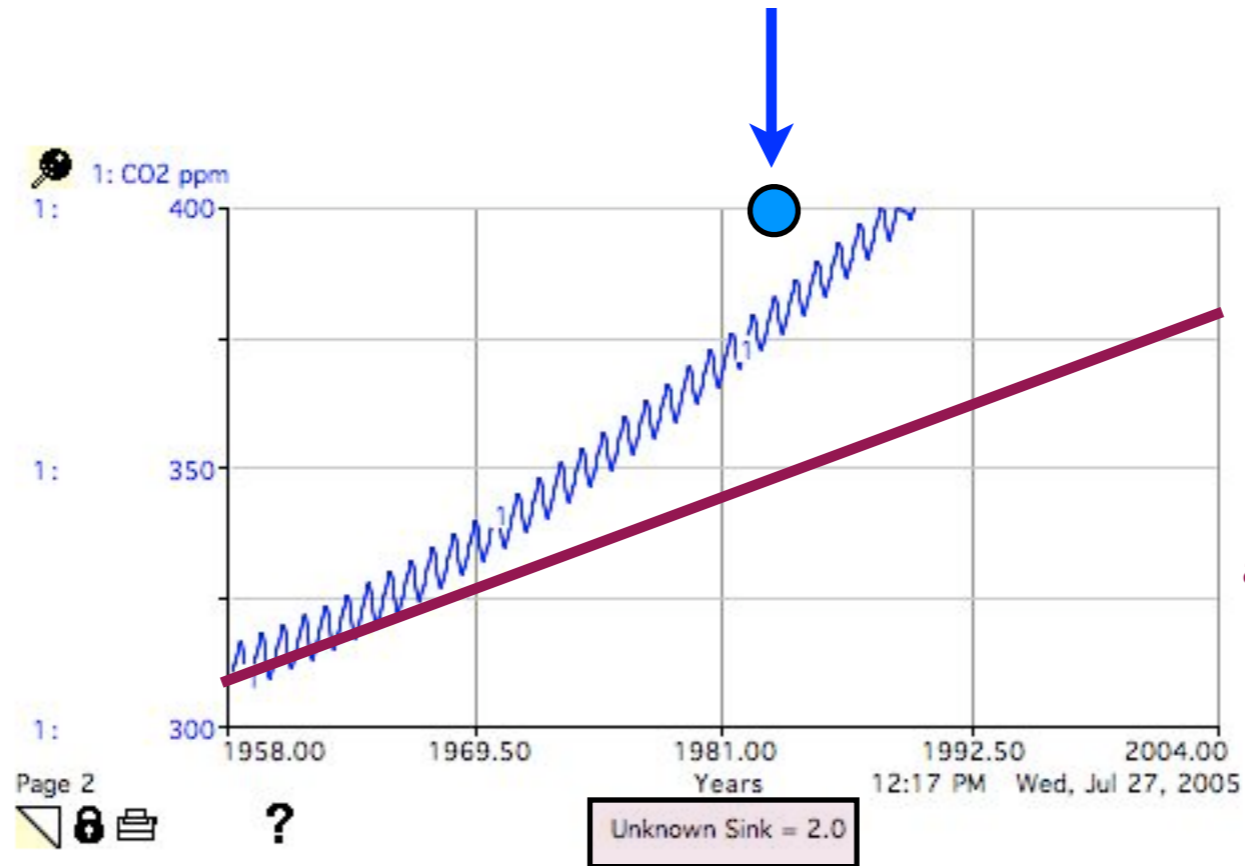

Setting the Unknown Sink to 2  
Gt/yr improves the model  
output, but we are still not in  
agreement with measurements.



The previous result with  
Unknown Sink = 0

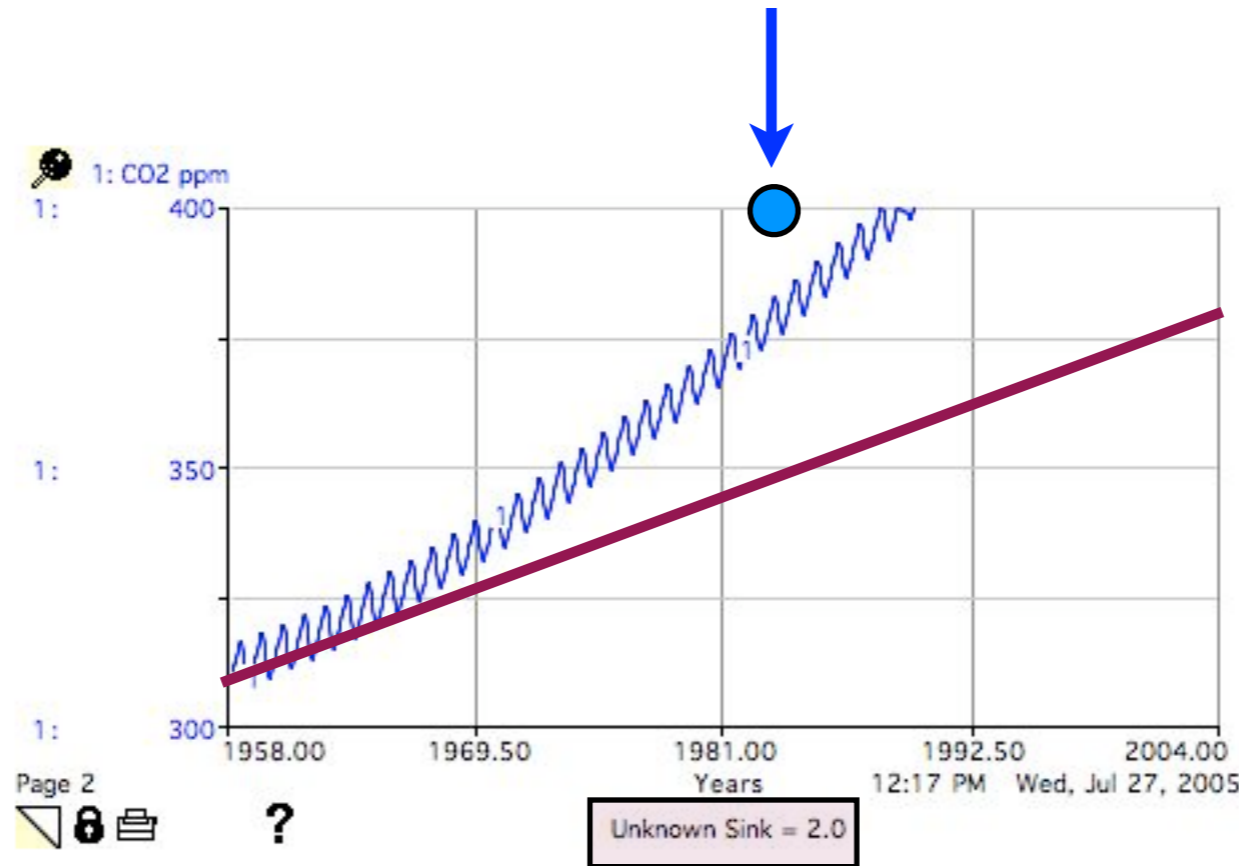

Setting the Unknown Sink to 2  
Gt/yr improves the model  
output, but we are still not in  
agreement with measurements.

Our “Net carbon to the atmosphere” was 5 Gt/yr; yet with an unknown sink = 2 Gt/yr we are not yet matching the measurement. What are we missing?

# Temporarily ignore the red curve.

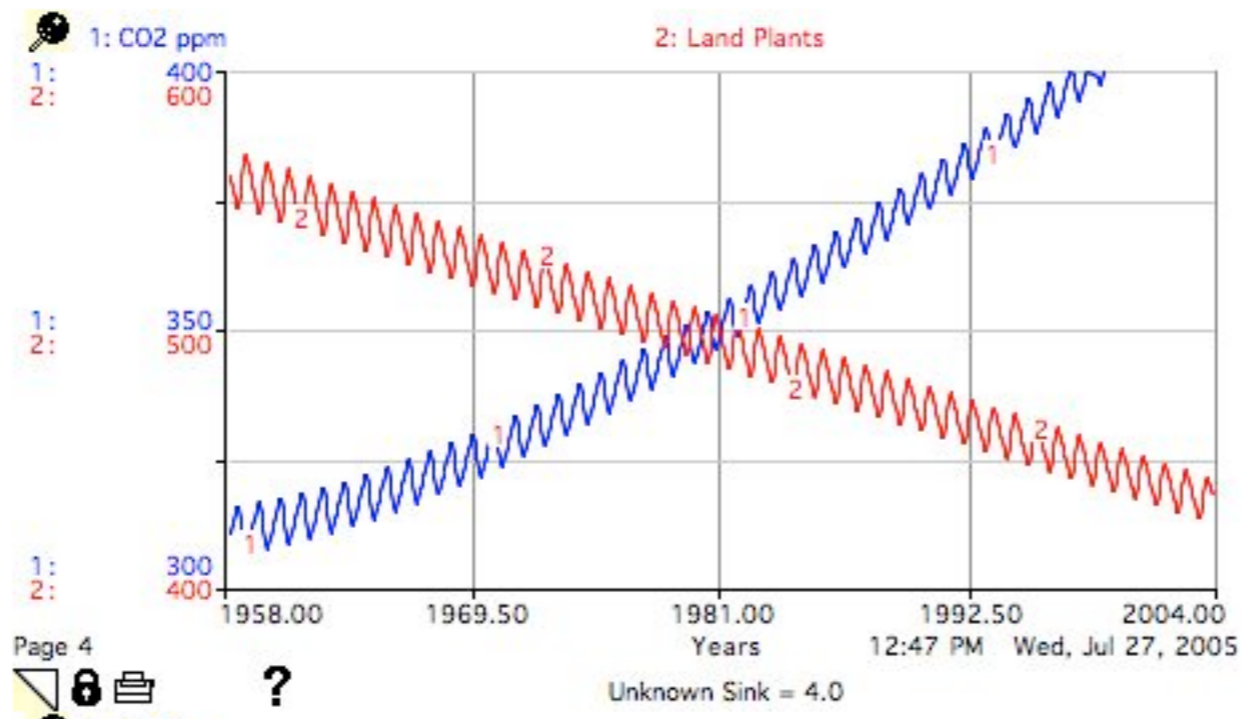

# Temporarily ignore the red curve.

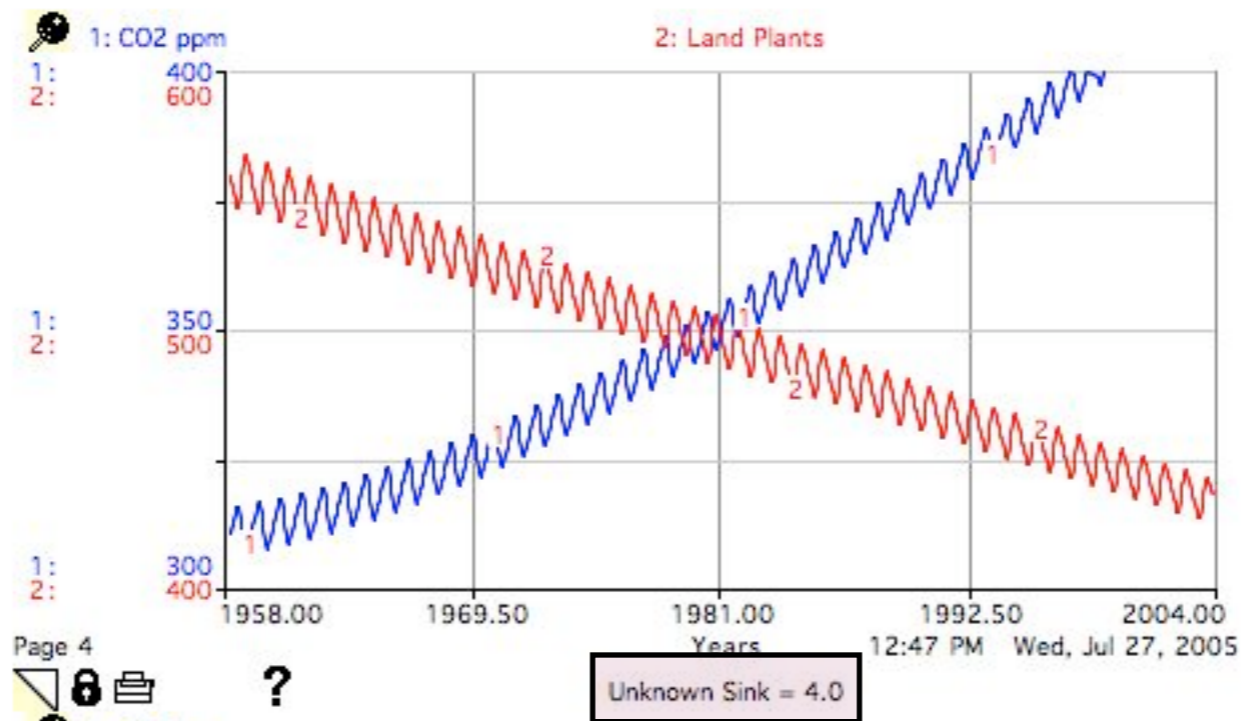



# Temporarily ignore the red curve.

The previous results with  
Unknown Sink = 0  
Unknown Sink = 2

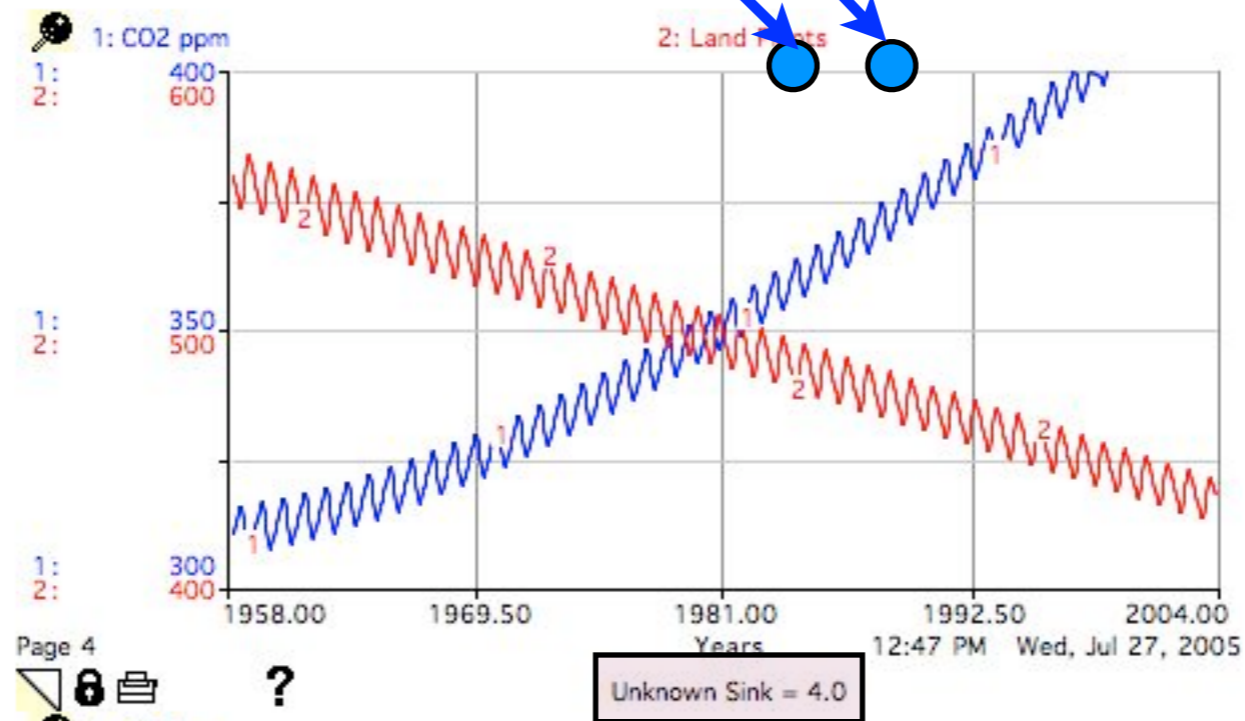

# Temporarily ignore the red curve.

The previous results with  
Unknown Sink = 0  
Unknown Sink = 2

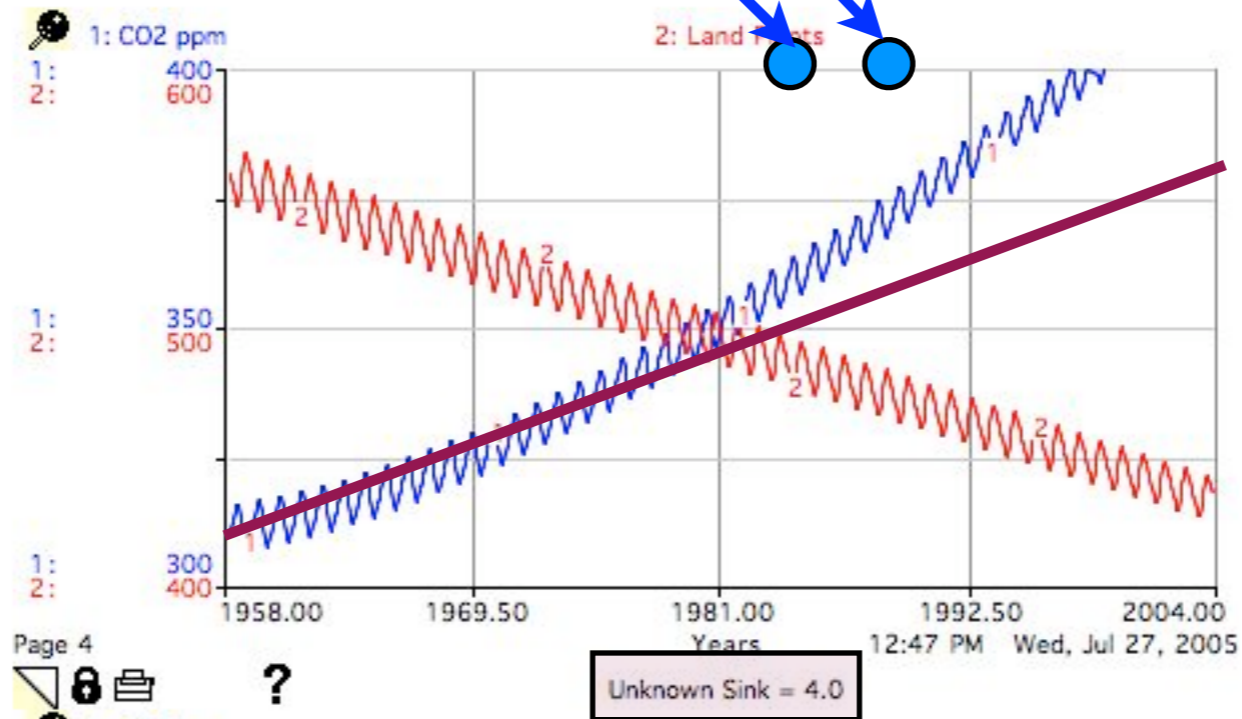

Setting the Unknown Sink to 4 Gt/yr improves the model output, but we are still not in agreement with measurements. Note the large deviation from the measurements in the last half of the model run.

The previous results with  
Unknown Sink = 0

Unknown Sink = 2

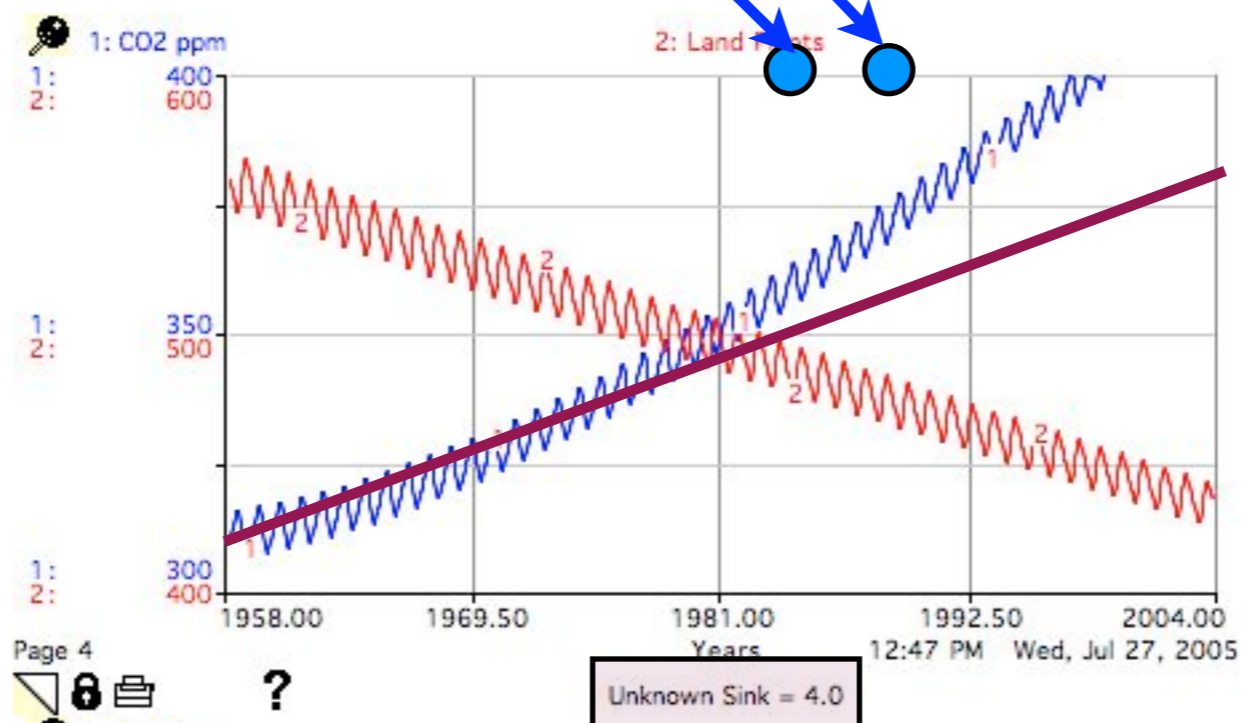

Setting the Unknown Sink to 4 Gt/yr improves the model output, but we are still not in agreement with measurements. Note the large deviation from the measurements in the last half of the model run.



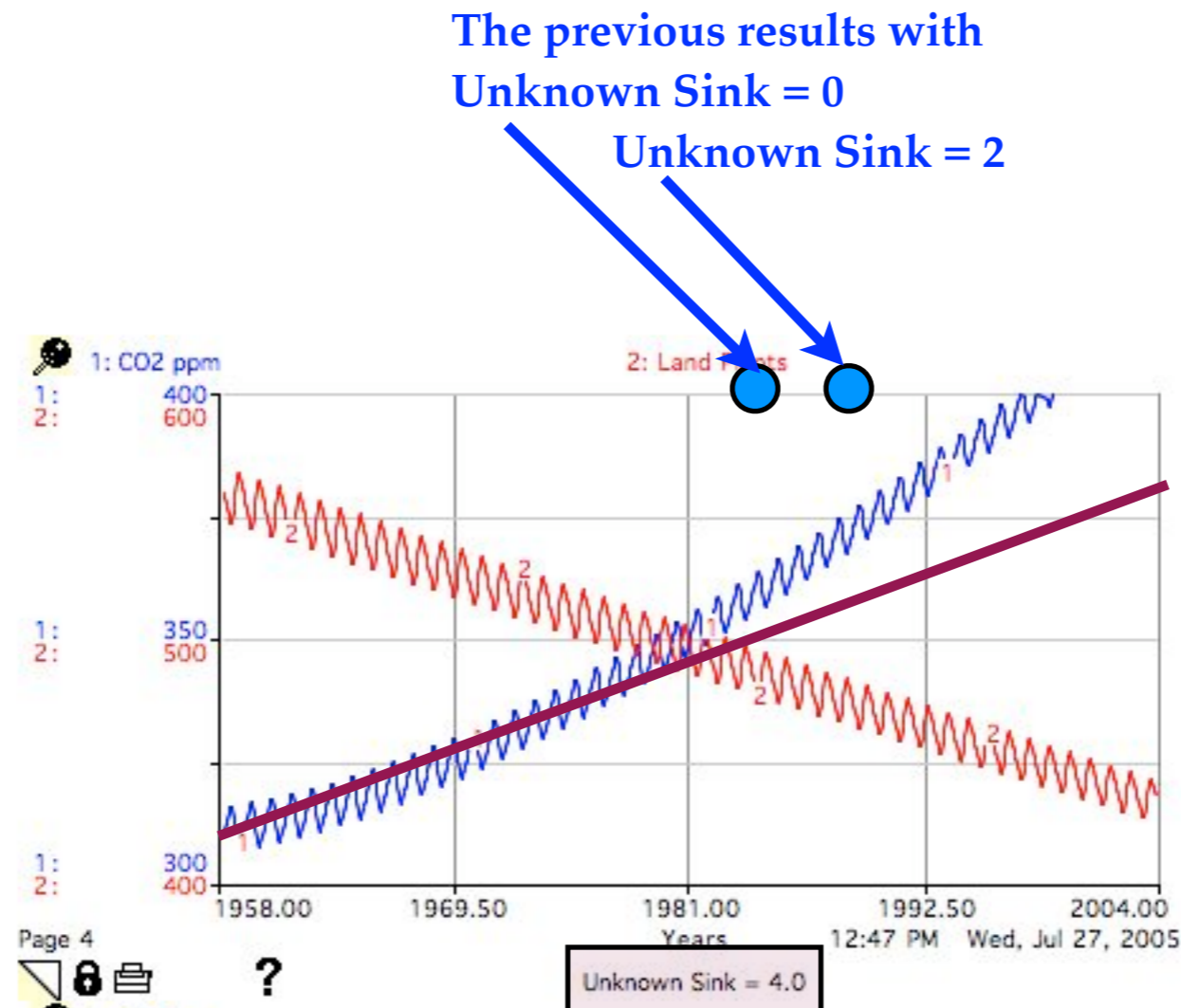

Setting the Unknown Sink to 4 Gt/yr improves the model output, but we are still not in agreement with measurements. Note the large deviation from the measurements in the last half of the model run.

On this model run we have also displayed the carbon in the Land Plants, which we now see is decreasing significantly because of deforestation. When Land Plants decrease, the photosynthesis also decreases and a major natural carbon sink decreases, so the Unknown Sink = 4 is insufficient.

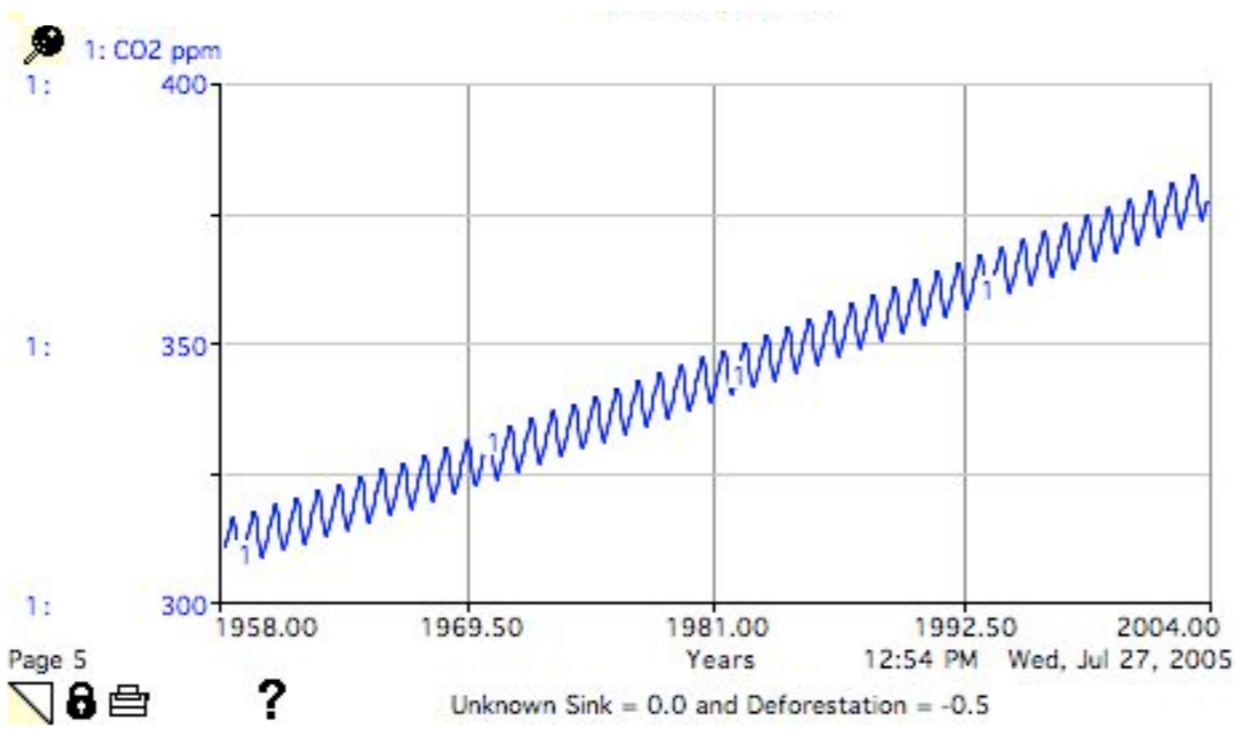

The previous results with  
Unknown Sink = 0

Unknown Sink = 2

Unknown Sink = 4

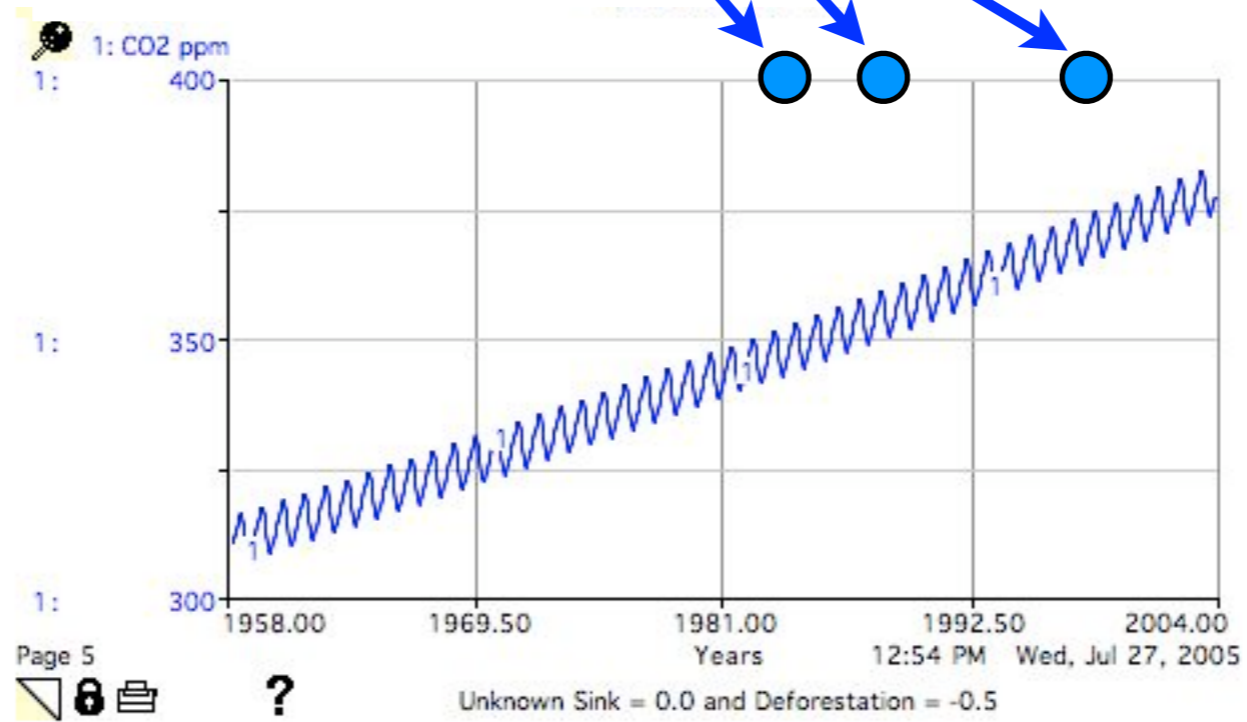



**Hypothesis. Deforestation seems to be inconsistent with the CO<sub>2</sub> measurements. What if the “Unknown Sink” is going into enhanced forest growth to compensate for the deforestation?  
This next model run sets Unknown Sink = 0 and “Deforestation” = -0.5, a small net gain.**

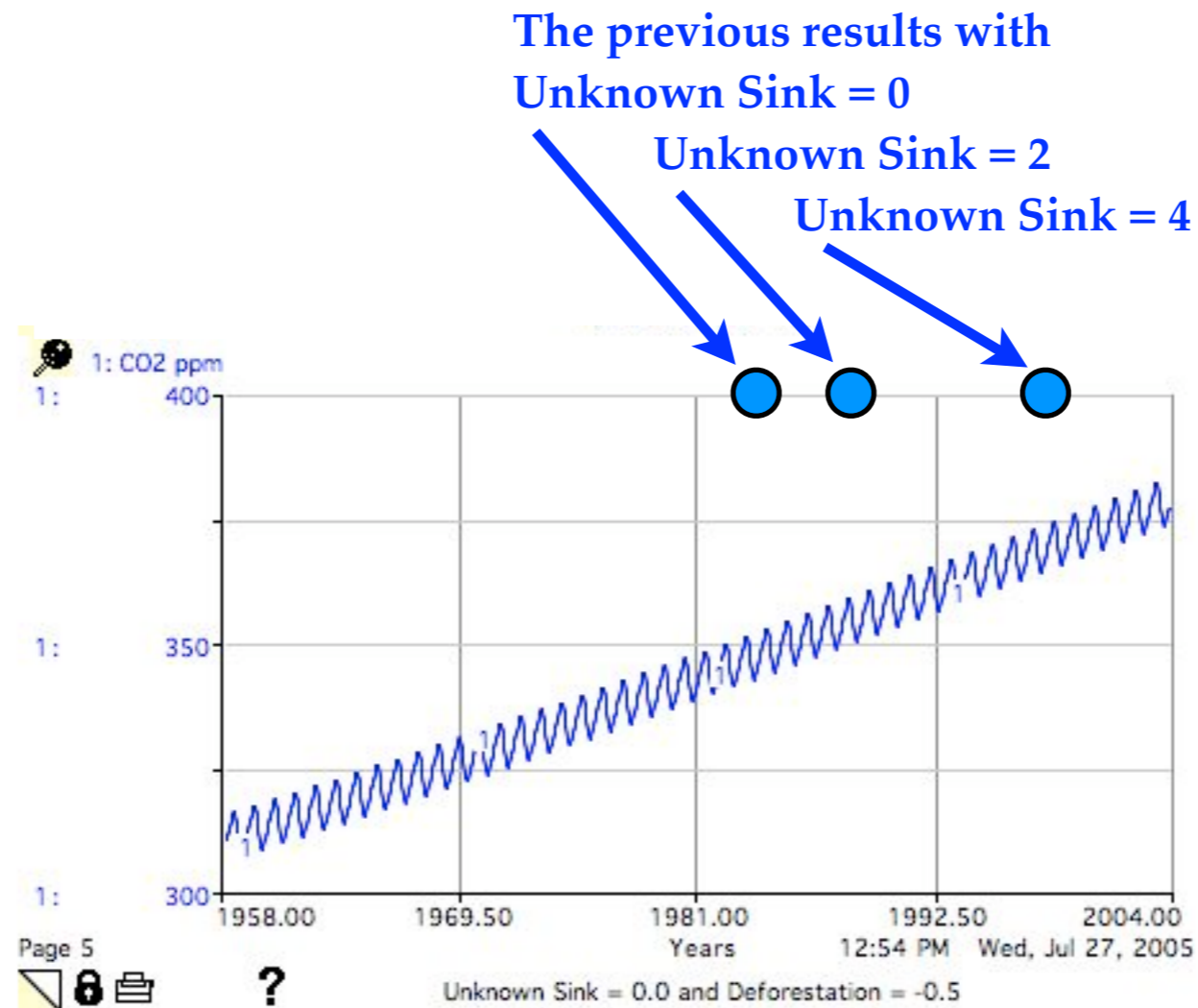

**Hypothesis. Deforestation seems to be inconsistent with the CO<sub>2</sub> measurements. What if the “Unknown Sink” is going into enhanced forest growth to compensate for the deforestation?  
This next model run sets Unknown Sink = 0 and “Deforestation” = -0.5, a small net gain.**

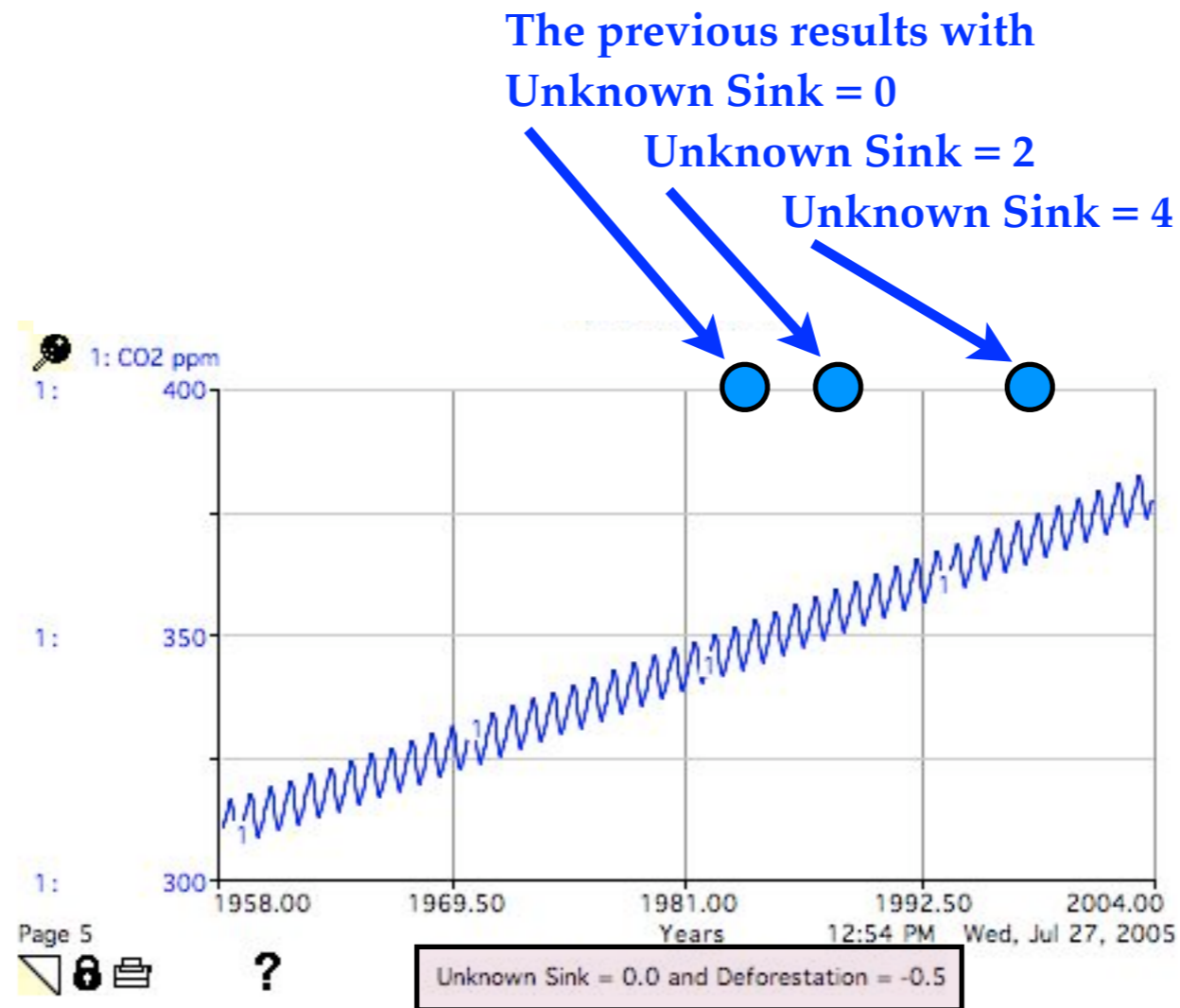

**Hypothesis. Deforestation seems to be inconsistent with the CO<sub>2</sub> measurements. What if the “Unknown Sink” is going into enhanced forest growth to compensate for the deforestation?  
This next model run sets Unknown Sink = 0 and “Deforestation” = -0.5, a small net gain.**

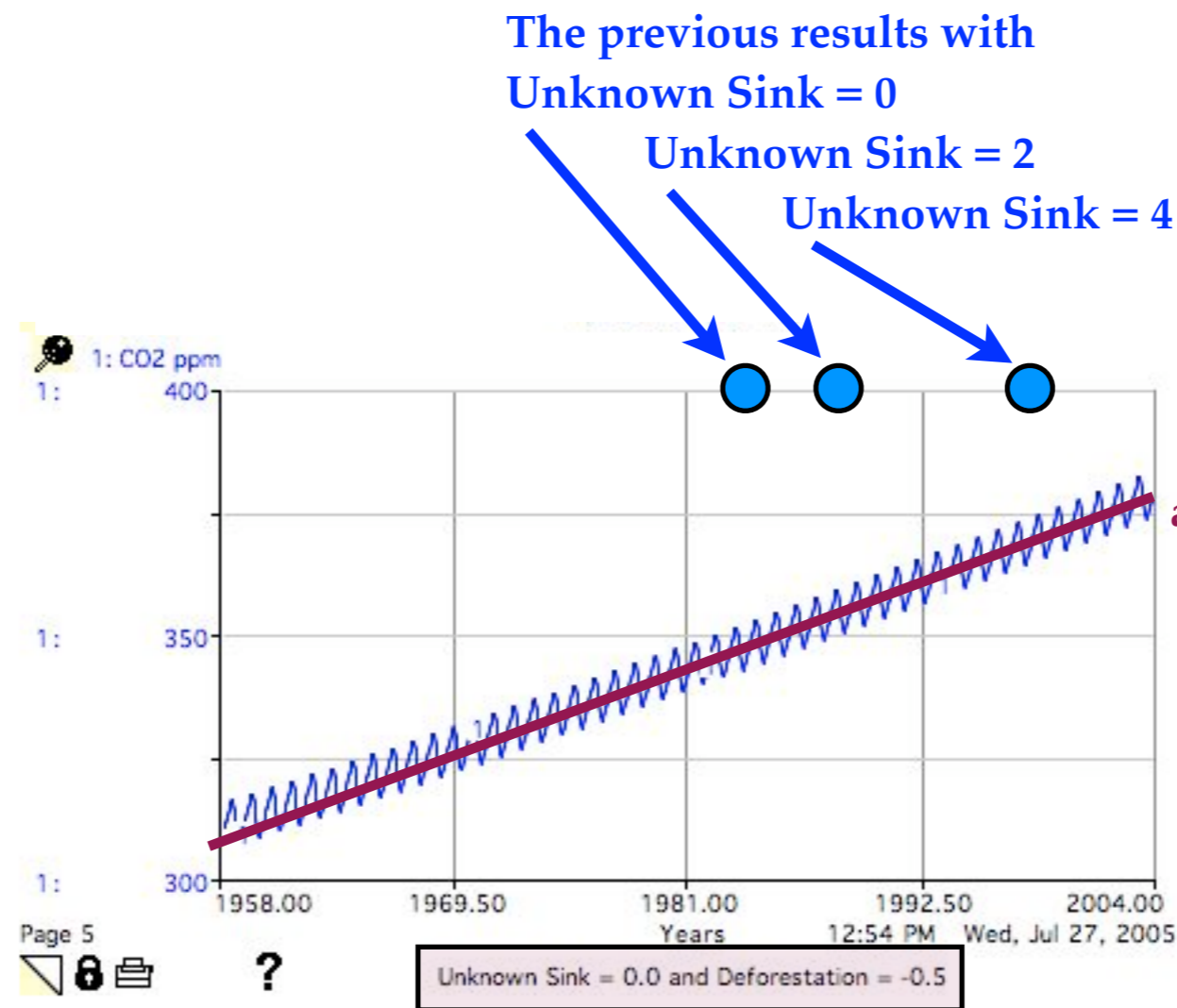

Setting the Unknown Sink to 0 and the Deforestation = -0.5 Gt/yr to represent a net increase in Land Plants produces agreement with measurements. This is called CO<sub>2</sub> fertilization, but it also represents natural recovery from previous deforestation.



**Hypothesis. Deforestation seems to be inconsistent with the CO<sub>2</sub> measurements. What if the “Unknown Sink” is going into enhanced forest growth to compensate for the deforestation?  
This next model run sets Unknown Sink = 0 and “Deforestation” = -0.5, a small net gain.**

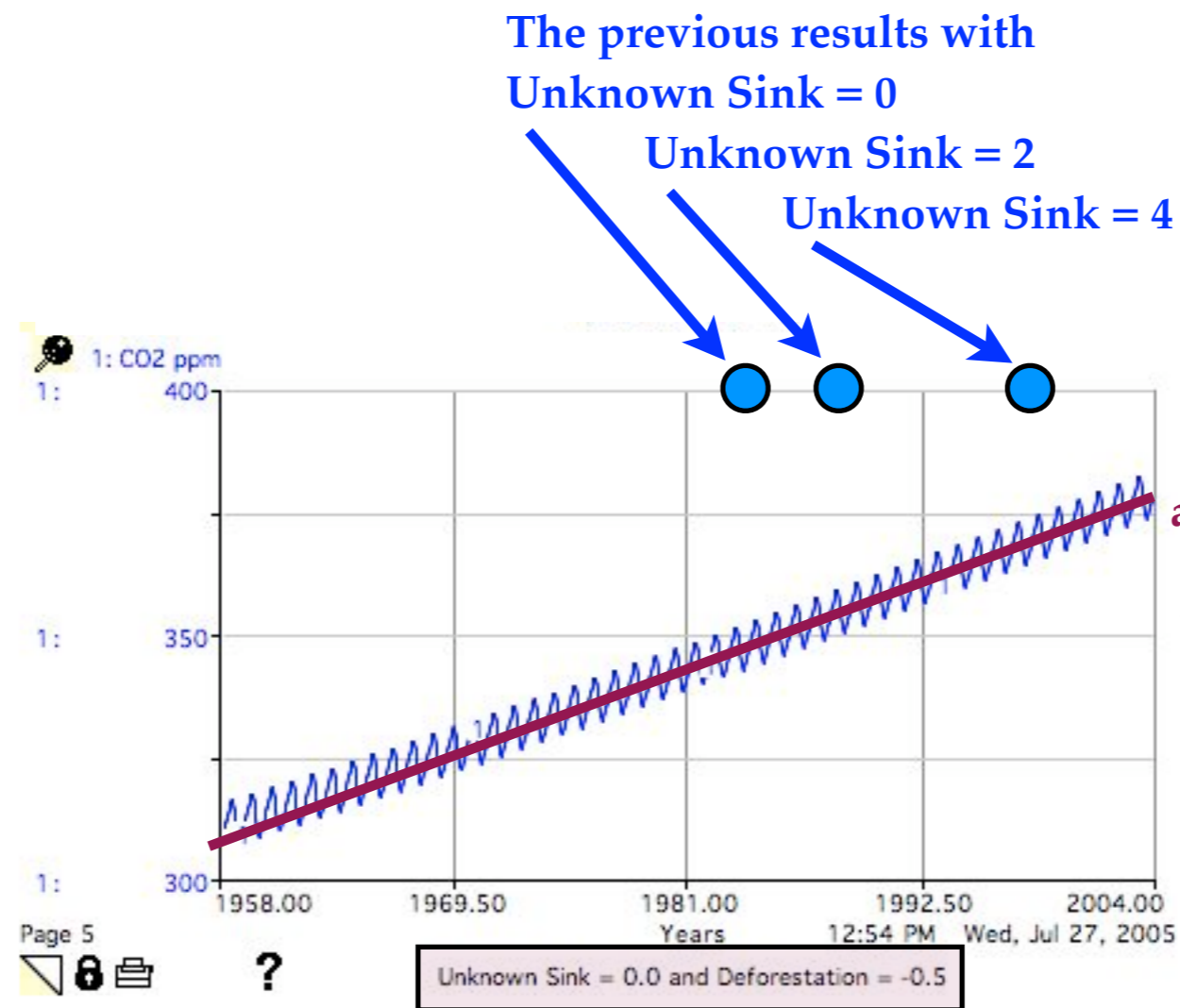

**Setting the Unknown Sink to 0 and the Deforestation = -0.5 Gt/yr to represent a net increase in Land Plants produces agreement with measurements. This is called CO<sub>2</sub> fertilization, but it also represents natural recovery from previous deforestation.**

**This is a very simple modeling exercise, but it can provide powerful insights into how the Earth system interacts with human perturbations.**

# Summary

- Greenhouse gasses warm the Earth's surface. Increasing greenhouse gasses increases the warming. This is a consequence of the Laws of Radiation Transfer and is unavoidable.
- Humankind's emissions of greenhouse gasses have increased the atmospheric load of these gasses beyond anything the Earth has experienced in 650,000 years.
- The Earth's global temperature is very difficult to determine; temperature is influenced by other processes in the Earth system, and the range of temperature change is so small ( $< 1^{\circ}\text{C}$ ) that it is an unconvincing parameter to use for public discussions. Sea level rise is only slightly better.
- More convincing evidence of global warming is available from changes in the Earth system that integrate the impacts of surface warming such as glaciers, ice sheets, sea ice, snow cover, ecological changes, etc. All of these measures point to a warming Earth.
- Humanity is currently emitting 7 Gt C/yr (fourteen trillion (14,000,000,000,000) pounds per year) into the atmosphere. The Earth can only handle half that quantity at best; the rest is accumulating in the atmosphere and is producing observable greenhouse warming of the Earth's surface.
- The way that the Earth is dealing with this part CO<sub>2</sub> overload is in increased forest growth and over saturation of oceanic CO<sub>2</sub>. Eventually, the oceans will release its excess CO<sub>2</sub> back into the atmosphere, and the new forest growth will mature and no longer be a sink for CO<sub>2</sub>.

# So, what do we do?

- The usual litany: energy conservation, renewable energy, etc. These will help and are good directions to move, but they are insufficient - too little, too late, but necessary.
- More oil and gas production: This is the wrong direction but unavoidable.
- Nuclear: Probably unavoidable - very expensive.
- Geoengineering:
  - (1) Fertilizing the oceans - probably won't work.
  - (2) Seeding clouds - questionable and expensive.
  - (3) Sequestering CO<sub>2</sub> underground - questionable reservoirs and expensive.
  - (4) Sequestering CO<sub>2</sub> on the ocean bottom - dangerous and expensive.

## My suggestion.

- Listen to what the Earth is telling us. Put it in the oceans and forests.
- Ocean storage is temporary and acidifying the ecosystem.
- Reforestation and afforestation is also temporary unless managed continuously. Mature trees must be cut and used so as to remove the wood from the decay cycle.
  - (1) Pulped wood will return to the atmosphere in short time.
  - (2) Construction wood will be sequestered for much longer time.
  - (3) Wood used for energy can displace fossil fuel thus is a permanent reduction in released CO<sub>2</sub>.



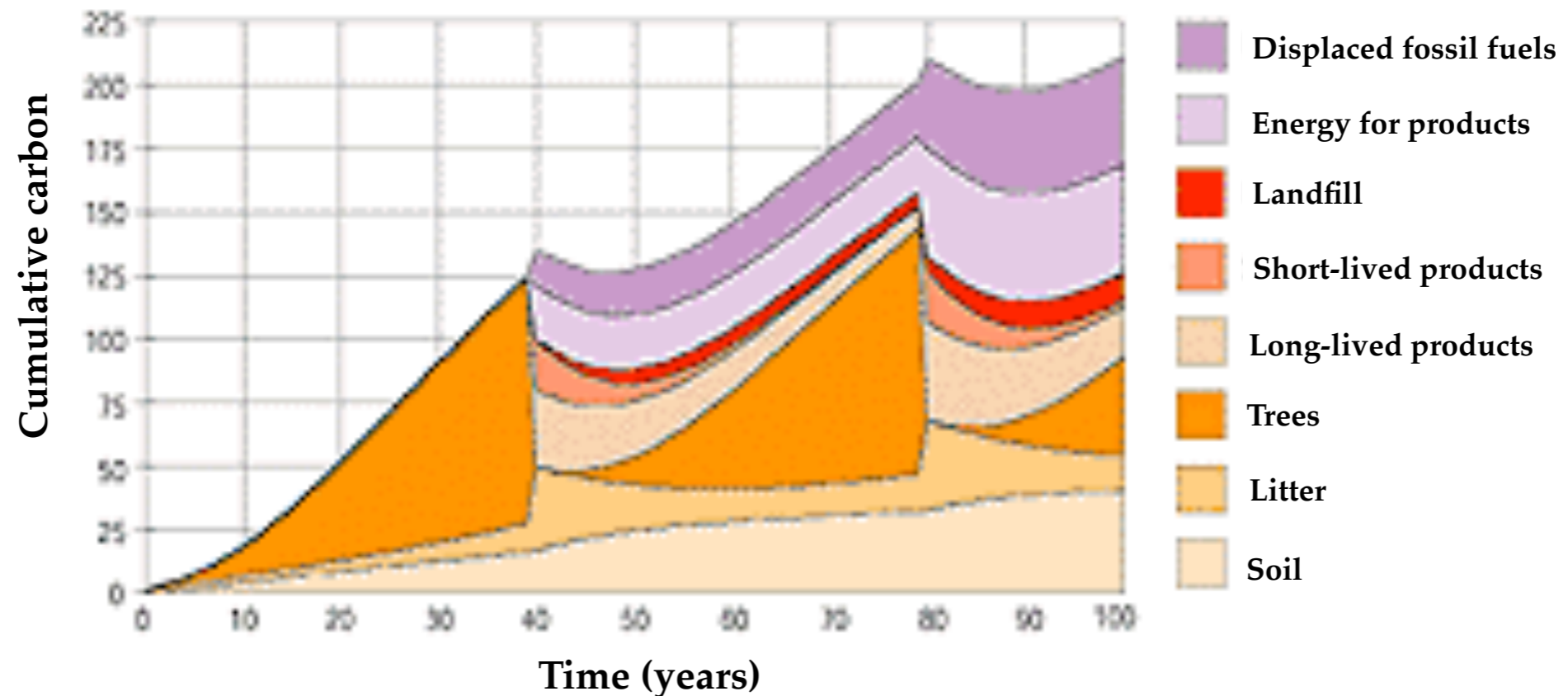

The figure shows cumulative carbon-stock changes for a scenario involving afforestation and harvest for a mix of traditional forest products with some of the harvest being used as a fuel. Values are illustrative of what might be observed in the southeastern USA or Central Europe. Regrowth restores carbon to the forest and the (hypothetical) forest stand is harvested every 40 years, with some litter left on the ground to decay, and products accumulate or are disposed of in landfills. These are net changes in that, for example, the diagram shows savings in fossil fuel emissions with respect to an alternative scenario that uses fossil fuels and alternative, more energy-intensive products to provide the same services.